

Duality relations between spatial birth-death processes and diffusions in Hilbert space

Chris D Greenman

School of computing sciences, University of East Anglia, Norwich Research Park,
Norwich, NR4 7TJ.

E-mail: C.Greenman@uea.ac.uk

Abstract. Spatially dependent birth-death processes can be modelled by kinetic models such as the BBGKY hierarchy. Diffusion in infinite dimensional systems can be modelled with Brownian motion in Hilbert space. In this work Doi field theoretic formalism is utilised to establish dualities between these classes of processes. This enables path integral methods to calculate expectations of duality functions. These are exemplified with models ranging from stochastic cable signalling to jump-diffusion processes.

1. Introduction

Birth-death processes are concerned with fluctuations in the size of a population of interest, such as growing populations of cells, chemical reactions between molecules, and connectivity of networks, for example. Standard approaches either have no spatial component and are just concerned with population size, or assume the spatially dependent population is fully mixed, with position playing no crucial role. However, for many problems of interest, spatial aspects are important. For example, chemical reaction fronts exhibit non-homogeneous spatial behaviour, and incorporating spatial effects into the birth-death interactions is important.

The theory behind stochastic analysis of fluctuating populations can be traced back to the master equation, originally developed by Kolmogorov [37]. Approaches to birth-death processes underwent crucial development by Kendall [34] and Karlin and McGregor [32, 33]. A fully stochastic description of systems of spatially interacting particles was collectively first achieved with the BBGKY hierarchy of equations [6, 7, 35, 36, 57]. Further development by Doi [17, 18] utilized machinery from quantum field theory to examine the dynamics, with path integral approaches for birth-death processes developed by Peliti [47]. System size approaches to mesoscopic analyses were developed by Van Kampen [54]. Comprehensive modern treatments detailing a fuller range of approaches can be found in [38, 53, 54].

Although the entities in a population of interest can be particulate in nature, such as molecules in a chemical reaction for example, they can also be individuals, queue

lengths, cells, network configurations to name a few. However, they shall henceforth be referred to as *particles*. The stochastic dynamics of these populations are characterized by having one or more species of particle, which can increase or decrease in number, due to processes such as birth, death, immigration and emigration, for example. Each particle is also often associated with a set of features of interest, such as position, momentum, age, state, or combinations thereof. These features can be intrinsically discrete, become discrete when lattice approximations to a continuum are considered, or can be continuous. We shall refer all such covariates with a *position*, although this is just a placeholder label that can refer to any feature of interest. The collective set of current positions constitute the state of the system, which are generally Markovian in nature. Note that if the positions are ignored then the state of the system reduces to a particle number count and has the appearance of a classical birth-death process, which spatial processes such as chemical reactions generalize. The techniques to analyse these systems are numerous [55], but we draw particular attention to Doi-Peliti methods, which are later utilized in this work.

Doi-Peliti methods allow (quantum) field theoretic approaches to analyse particle dynamics, and were first introduced by Doi [17, 18] with applications to chemical reaction kinetics. A lattice based path integral formulation was later developed for birth-death processes by Peliti [47]. These papers have seen a plethora of applications; birth-death processes, age structured systems [25], neural networks [9], algebraic probability [43], knot theory [49], critical dynamics [53], and phylogeny [31] is a non exhaustive list of examples. Although most path integral approaches are based on the discretization process in [47], more recent work has seen the development and application of continuous analytic rather than lattice based path integral approaches [25, 56]. Systems with exclusion or partial exclusion properties have also seen the development of fermionic [50, 53] and parafermionic [26, 51] approaches to analysis.

Diffusion processes, at face value, are seemingly unrelated, and originally arose as models associated with thermodynamics of heat, and also of Brownian motion [8]. Models of diffusion can be constructed in any dimension, for example, share prices (one), Brownian motion (two), heat (three), and allelic frequencies of a range of genes ($n \in \mathbb{N}$) in a large population are described by Wright-Fisher diffusion. More recently, techniques have emerged that consider diffusion acting on Hilbert and Banach spaces. The diffusions have corresponding stochastic equations that involve two possible classes of generalised Brownian motion, known as cylindrical and Q-Brownian motion [3, 4, 5, 13, 20, 23]. Some biological applications of these processes can be found in [13], including the stochastic cable equation that can model neuronal activity [21], and models of allelic frequencies in a position dependent population, modelled by the infinite dimensional Wright-Fisher diffusions, otherwise known as Fleming-Viot processes, which can also be analysed by Martingale methods [14, 15].

These seemingly distinct areas of stochastic particle interactions and diffusion processes can be connected by notions of duality. Duality between stochastic processes provide a connection whereby a certain mean of one process can be related to a

mean of another process, usually expressed via expectation of a common duality function. A classic example is the duality between Wright-Fisher diffusion and the Kingman coalescent process (a death-process related to ancestral convergence under time reversal) [30, 41]. The more recent generalizations to Fleming-Viot processes [14, 15] involve spatially dependent birth-death processes that incorporate mutation, selection, migration and genealogical structure, which are shown to be dual to diffusions on function valued spaces.

The notion of duality extends well beyond these classes of stochastic process and approaches to finding dual processes is varied in both method of derivation and application. General background on duality and approaches for interacting particles can be found in [38]. A wide class of dualities based on symmetry arguments can be found in [22, 24, 48]. A comprehensive review of duality in Markov processes was recently provided by Jansen and Kurt [30]. A review of duality in genetic processes can be found in [10, 41], along with the extensive range of applications in [14, 15]. The discrete Fock spaces of Peliti can be utilized to derive general dualities between birth-death processes and (mostly) one dimensional diffusions [42, 44, 45, 46, 47].

If (discrete) birth-death processes are generalised to spatially dependent systems, it is natural to enquire, firstly, how (or if) the field theoretic approaches to deriving dualities in [42, 44] can be adapted, and secondly, how do the results compare to those found via Martingale techniques in [14, 15]. These are the questions considered in this work, where we develop path integral approaches to analyse duality between spatial birth-death models and infinite dimensional diffusion processes. These methods utilize a continuous Doi formalism [17, 18, 25, 56] rather than the discrete lattice approaches of Peliti [47]. We will show that the field theoretic approach offers an alternative method of deriving some of the dualities seen in [14, 15]. Furthermore, the use of perturbation methods will allow the construction of combinatorial expressions for some expectations of interest, and the use of fermionic approaches will also result in some novel dualities not (currently) seen with martingale techniques in [14, 15].

The paper is arranged as follows. The next section introduces the Doi formalism of field theory used to model both the spatial birth-death and infinite dimensional diffusion processes. This extends the formalism used in [25] and will enable diffusion on infinite dimensional Hilbert (function) spaces to be considered. This will also lead to the construction of associated path integrals. Section 3 introduces cylindrical and Q-Brownian motion, providing the means to convert these stochastic processes into Doi-Peliti formalism. Section 4 then explains and exemplifies how dualities between these different classes of processes can be constructed with this formalism. Section 5 explores path integral forms for expectations of duality functions using a stochastic cable process to exemplify the methods. This enables the development of perturbation methods, which are used to produce novel combinatorial expressions for correlation functions of interest. Section 6 explores techniques from fermionic field theory. This approach can deal with technical difficulties presented by some models, which would seem to preclude forming dualities using the methods of Section 5. Section 7 considers

forms of self-duality between pairs of particle systems and between pairs of Hilbert space diffusions, providing a path integral interpretations that generalize dualities seen elsewhere. Conclusions complete the work.

2. Doi formalism

In this section the field theoretic machinery of Doi is introduced. We firstly utilize it to describe stochastic, diffusive, interacting particle based models. This part shall be relatively brief as more comprehensive introductions can be found in [17, 18, 25]. Secondly, we describe how the formalism can be adapted to model diffusion in infinite dimensional Hilbert space, by deriving the associated Fokker-Plank equation.

2.1. Doi Machinery and Particle Models

Next then, we introduce the basics of Doi machinery. Assume a single species population of spatially dependent, stochastically interacting particles. The state of the system at any one point in time is described by a vector of the form \mathbf{q}_n , where n is the current number of particles and component q_i is the position of the i^{th} molecule. The term q_i can refer to anything describing the state, such as the age of the i^{th} member of a population, or the positions and velocities of a physical molecule. The term q_i , being a component of (emboldened) vector \mathbf{q}_n , is thus an abuse of notation, as q_i can itself be vector valued. However, by defining it as the information associated with one particle (the i^{th}), the distinction should be clear. We let Υ denote the space of interest, that is, $q_i \in \Upsilon$ and $\mathbf{q}_n \in \Upsilon^n$. We also suppose that d is the dimension of space Υ .

The population will be represented by a ket $|\mathbf{q}_n\rangle$. This can be defined with the aid of creation and annihilation operators, where $|\mathbf{q}_n\rangle = \prod_{i=1}^n \psi_{q_i}^\dagger |\emptyset\rangle$, where $|\emptyset\rangle$ denotes the empty state and the operators obey the usual commutation relations

$$[\psi_{q_i}, \psi_{q_j}^\dagger] = \sum_{\sigma \in S_d} \prod_{k=1}^d \delta((q_i)_k - (q_j)_{\sigma(i)}), \quad [\psi_{q_i}, \psi_{q_j}] = [\psi_{q_i}^\dagger, \psi_{q_j}^\dagger] = 0, \quad (1)$$

where $(q_i)_k$ is the k^{th} component of q_i , σ is a permutation from the finite group S_d , meaning $((q_i)_{\sigma(1)}, (q_i)_{\sigma(2)}, \dots, (q_i)_{\sigma(d)})$ is a reordering of the components of q_i . Thus we have a sum over all permutations between elements of q_i and q_j . The kets $|\mathbf{q}_n\rangle$ are ‘pure’ states, representing a specific population state. However, the systems we wish to describe are random processes, with a random vector $\mathbf{q}(t)$ that varies in component values (positions) and in length (population size). To introduce stochastic properties associated with $\mathbf{q}(t)$ we have a general state of the form

$$|\chi_t\rangle = \sum_{n=0}^{\infty} \int_{\Upsilon^n} \frac{d\mathbf{q}_n}{n!} f(\mathbf{q}_n, t) |\mathbf{q}_n\rangle, \quad (2)$$

where $\frac{f(\mathbf{q}_n, t)}{n!}$ is the probability density for state $\mathbf{q}(t) = \mathbf{q}_n = (q_1, q_2, \dots, q_n)$, normalized in the sense that $\sum_{n=0}^{\infty} \int_{\Upsilon^n} \frac{d\mathbf{q}_n}{n!} f(\mathbf{q}_n, t) = 1$. Note that the integral is over all possible

values of $\mathbf{q}_n \in \Upsilon^n$ meaning we can assume f is symmetric in its arguments, as the anti-symmetric parts will integrate to zero. That is, we can write $f(\mathbf{q}_n) = f(\pi(\mathbf{q}_n))$, where we define, with abuse of notation, $\pi(\mathbf{q}_n)$ to be a reordering $(q_{\pi(1)}, \dots, q_{\pi(n)})$ of the elements of \mathbf{q}_n , with permutation $\pi \in S_n$. Then we can interpret $\frac{f(\mathbf{q}_n, t)}{n!}$ as the density associated with a random labelling of the n (indistinguishable) particles. Then, summing over all possible labellings $\sum_{\pi \in S_n} \frac{f(\pi(\mathbf{q}_n), t)}{n!} = f(\mathbf{q}_n, t)$ provides the probability density that the current state $\mathbf{q}(t)$ is composed of the set of (unordered) particles $\{q_1, q_2, \dots, q_n\}$. This density can be recovered from $|\chi_t\rangle$ via

$$f(\mathbf{q}_m, t) = \langle \mathbf{q}_m | \chi_t \rangle. \quad (3)$$

We can then use the creation and annihilation operators to represent interactions of interest. For example, consider the following jump-diffusion processes. If A_p represents a particle at position p , we have

$$A_p \xrightarrow{R_{pq}} A_q, \quad A_p \xrightarrow{D_p}, \quad (4)$$

meaning particles jump from positions p to q at rate R_{pq} , and diffuse at position dependent rate D_p . This is a somewhat trivial model, having fixed particle number and no inter-particle interactions, but will set the scene for duality.

Then, following [17], the Liouvillian operator describing this process will take the form

$$\mathcal{L} = \int_{\Upsilon} dp D_p \psi_p^\dagger \nabla_p^2 \psi_p + \iint_{\Upsilon^2} dp dq R_{pq} (\psi_q^\dagger \psi_p - \psi_p^\dagger \psi_q), \quad (5)$$

where the dynamics are described formally by the Heisenberg evolution equation,

$$|\chi_t\rangle = e^{\mathcal{L}t} |\chi_0\rangle, \quad (6)$$

for some initial state $|\chi_0\rangle$.

The last technical requirement is the notion of a coherent state. These are needed to calculate averages and construct path integrals, but are also needed to form processes dual to particle systems. Specifically then, for a function x acting on Υ we have coherent state

$$|x\rangle = \exp \left\{ \int_{\Upsilon} dp x(p) \psi_p^\dagger \right\} |\emptyset\rangle. \quad (7)$$

These act as eigenstates for annihilation and creation operators in the sense that

$$\psi_p |x\rangle = x(p) |x\rangle, \quad \psi_p^\dagger |x\rangle = \frac{\delta}{\delta x(p)} |x\rangle, \quad (8)$$

which can be shown via the commutation relations in Eq. 1. The later equation contains a functional derivative meant in the sense that $\langle f | \psi_p^\dagger |x\rangle = \frac{\delta}{\delta x_p} \langle f |x\rangle$. Note, we shall frequently make use of the adopted shorthand notation $x_p \equiv x(p)$. The commutation relations can also be used to show that $\langle x|y\rangle = e^{\int_{\Upsilon} dp xy}$.

This is all the machinery that is required for analysing models of interest. For example, the master equation can be derived from the expression $\frac{\partial f(\mathbf{q}_m, t)}{\partial t} = \langle \mathbf{q}_m | \mathcal{L} | \chi_t \rangle$.

The resulting integral-differential equations often take the form of BBGKY like hierarchies [6, 7, 35, 36, 57]. These are generally difficult to solve, and we do not explore these further here (see [11, 25, 27] for examples).

A slightly simpler problem is to investigate correlation functions for the system. The m^{th} order correlation function $X(\mathbf{q}_m)$ represents the probability density for finding m particles with positions given by the set $\{q_1, q_2, \dots, q_n\}$, and satisfies the dynamic equation $\frac{\partial X(\mathbf{q}_m)}{\partial t} = \langle 1 | \prod_{i=1}^m \psi_{q_i} \mathcal{L} | \chi_t \rangle$. This also results in hierarchies of equations, although they tend to be simpler [11, 25, 27]. Note here that the bra $\langle 1 |$ is the coherent state with constant function 1 (rather than a single particle at position 1).

One alternative approach to calculate either function f or X is via path integrals. These can be constructed either through spatial discretization techniques first exemplified with the Fock space methods in [47], or more directly using the Doi framework through continuous techniques [25]. This gives two approaches for both functions; solving PDEs or calculating path integrals. Although we will not consider these choices to analyse f or X further here, we will later consider both techniques to investigate expectations of duality functions of interest.

2.2. Doi Machinery and Diffusion Processes

Next, the Doi machinery described above and found in [17, 18, 25, 42, 45] shall be extended to deal with stochastic infinite dimensional processes. In particular, we wish to construct such a process dual to the one given in Eq. 4. Duality will be established later.

First we introduce the time dependent state

$$|\Psi_t\rangle = \int \mathcal{D}x P[x; t] |x\rangle, \quad (9)$$

where we have path integration over real valued functions x meant in the sense $\int \mathcal{D}x P[x; t] |x\rangle = \prod_p \int_{-\infty}^{\infty} d[x(p)] P[x; t] e^{\epsilon \sum_p x(p) \psi_p^\dagger} |\phi\rangle$, with positions p taken on a lattice spanning Υ with spacing size ϵ . Eq. 9 is analogous to Eq. 2 and $P[x; t]$ is interpreted as the (infinite dimensional) probability density functional associated with function x . Analogously to Eq. 3, we can (formally at least) recover this functional via

$$P[x; t] = \int \mathcal{D}y e^{-i \int_{\Upsilon} dy y x} \langle y | \Psi_t \rangle. \quad (10)$$

Next, analogous to Eq. 6, we introduce dynamics with an evolution equation of the form

$$|\Psi_t\rangle = e^{\mathcal{L}^\dagger t} |\Psi_0\rangle. \quad (11)$$

The choice of adjoint operator \mathcal{L}^\dagger will become apparent when duality is later considered.

Then on the one hand, for general bra $\langle g |$, we find

$$\langle g | \frac{\partial}{\partial t} |\Psi_t\rangle = \int \mathcal{D}x \frac{\partial P[x; t]}{\partial t} \langle g | x \rangle = \frac{\partial}{\partial t} \int \mathcal{D}x P[x; t] G[x], \quad (12)$$

where we have introduced general functional $\langle g|x \rangle = G[x]$. But we can also construct the following, using the specific adjoint \mathcal{L}^\dagger of the operator corresponding to the jump-diffusion model above, to give

$$\langle g | \frac{\partial}{\partial t} |\Psi_t \rangle = \langle g | \frac{\partial}{\partial t} e^{\mathcal{L}^\dagger t} |\Psi_0 \rangle = \int \mathcal{D}x P(x, t) \langle g | \mathcal{L}^\dagger |x \rangle.$$

Then using the eigen-operator relations in Eq. 8 we find,

$$\begin{aligned} \frac{\partial}{\partial t} \int \mathcal{D}x P[x; t] G[x] &= \int \mathcal{D}x P[x; t] \left\{ \int_{\Upsilon} dp D_p(\nabla^2 x)(p) \frac{\delta}{\delta x_p} \right. \\ &\quad \left. + \iint_{\Upsilon^2} dp dq R_{pq}(x_q - x_p) \frac{\delta}{\delta x_p} \right\} G[x]. \end{aligned} \quad (13)$$

Thus we have the structure of a Fokker-Planck equation (the form seen for Hilbert spaces [13, 23, 5, 3]); $\frac{\partial}{\partial t} \int_H d\mu(x, t) G[x] = \int_H d\mu(x, t) (LG)[x]$, where $\int d\mu(x, t) \equiv \int \mathcal{D}x P[x; t]$ is the measure, G a general functional and we have Kolmogorov operator

$$L = \int_{\Upsilon} dp D_p(\nabla^2 x)(p) \frac{\delta}{\delta x_p} + \iint_{\Upsilon^2} dp dq R_{pq}(x_q - x_p) \frac{\delta}{\delta x_p}. \quad (14)$$

Note that the Kolmogorov operator is obtained in general via the correspondence

$$\langle g | \mathcal{L}^\dagger(\psi_p^\dagger, \psi_p) |x \rangle = L \left(\frac{\delta}{\delta x_p}, x_p \right) G[x]. \quad (15)$$

There are two key things to note with this expression. Firstly, it is assumed that Liouvillian operator \mathcal{L}^\dagger is in normal form. That is, the creation operators are left of the annihilation operators. Although all operators discussed will be written in normal form, this can readily be achieved for general forms of operator with the aid of the commutation relations in Eq. 1. Secondly, the order of operators (following the mapping $\psi_p^\dagger \rightarrow \frac{\delta}{\delta x_p}$ and $\psi_q \rightarrow x_q$) is reversed in the Kolmogorov operator. For example $\langle g | \psi_p^\dagger \psi_q |x \rangle = x_q \frac{\delta}{\delta x_p} G[x]$. We are then left with the question of whether the Kolmogorov operator in Eq. 14 corresponds to a stochastic process of interest.

For the jump-diffusion process, there exists the probability conservation condition $\langle 1 | \mathcal{L} = 0$. This condition is necessary but not sufficient; it does not guarantee positive probabilities, for example. We can apply a similar condition for the function process from Eq. 9, where we see that $\langle \emptyset | \mathcal{L}^\dagger = 0$ needs to be satisfied to guarantee $\frac{\partial}{\partial t} \int \mathcal{D}x P[x; t] = 0$, which is certainly true for the operator in question. However, this is also not a sufficient condition for a probability process and we need better understand when operators \mathcal{L} correspond to random processes on function spaces. The main classes of process, which generalize Brownian motion, are described in the next section.

3. Brownian motion in Hilbert space

Brownian motion in infinite dimensional Hilbert space is a well characterized phenomenon. The two main classes of stochastic process are known as cylindrical and Q-

Brownian motions. These are briefly introduced below, only covering the salient points. More comprehensive treatments and technical specifics can be found in [3, 5, 13, 23, 28].

Analogous to Brownian motion in finite dimensional space, a stochastic PDE for Brownian motion in Hilbert space can be written, taking the form

$$dX_t = A(X_t)dt + B(X_t)dW_t, \quad (16)$$

where X_t is a stochastic process with values in a Hilbert space H , and the operators $A : H \rightarrow H$ and $B : H \times H \rightarrow H$ are generally non-linear in nature. Here W_t is a Q -Brownian motion taking values in H , with

$$W_t = \sum_{i=0}^{\infty} \lambda_i^{\frac{1}{2}} W_t^{(i)} \xi_i. \quad (17)$$

This is a sum over independent standard one dimensional Brownian motions $W_t^{(i)}$, where λ_i and ξ_i are eigenvalues and (orthonormal) eigenfunctions of a trace class operator Q . The trace class property means that $\lambda_i \geq 0$, $\sum_{i=0}^{\infty} \lambda_i < \infty$, and furthermore $\text{Tr}(Q) = \sum_k \langle Qe_k, e_k \rangle_H$ is finite for any orthonormal basis e_k of H (such as ξ_k), with value $\text{Tr}(Q)$ independent of the chosen basis.

Although the operator $Q = I$ is not trace class, it corresponds at the formal level to the process where $dW_t(p)dW_t(q) = dt \delta(p - q)$ and is known as cylindrical Brownian motion [28].

Then the Kolmogorov operator corresponding to the process given in Eq. 16 is commonly given by [3, 5, 13, 23]

$$(LG)[x] = \langle G_x(x), A(x) \rangle_H + \frac{1}{2} \text{Tr}(G_{xx}(x)B(x)QB(x)^*). \quad (18)$$

The terms G_x and G_{xx} are the functional forms of the grad and Hessian [12]. The grad is simply the functional derivative $G_x = \frac{\delta G}{\delta x_p}$, but given Eq. 18, is usefully expressed via the differential of functional $G[x]$, where

$$DG[x; y] = \langle G_x(x), y \rangle_H = \int_{\Upsilon} dp \frac{\delta G}{\delta x_p} y_p. \quad (19)$$

The Hessian is the differential of the grad, $G_{xx} = DG_x$, which can be given in terms of second differential, where,

$$D^2G[x; y, z] = \langle G_{xx}(x)(y), z \rangle_H = \iint_{\Upsilon^2} dp dq \frac{\delta^2 G}{\delta x_p \delta x_q} y_p z_q. \quad (20)$$

Now if we take the functions $A(x)(p) = D_p(\nabla^2 x)(p) + \int_{\Upsilon} dq R_{pq}(x_q - x_p)$, and $B(x) = 0$, the trace term in Eq. 18 is zero and

$$\begin{aligned} \langle A(x), G_x(x) \rangle_H &= DG(x)(A(x)) = \int_{\Upsilon} dp \frac{\delta G}{\delta x_p} (A(x)(p)) \\ &= \int_{\Upsilon} dp D_p \nabla_p^2(x_p) \frac{\delta G}{\delta x_p} + \iint_{\Upsilon^2} dp dq R_{pq}(x_q - x_p) \frac{\delta G}{\delta x_p}. \end{aligned} \quad (21)$$

Thus we have recovered the terms from Eq. 14, and find that X_t is a (deterministic) process of the form

$$dX_t(p) = \left(D_p \nabla_p^2 X_t(p) + \int_{\Upsilon} dq R_{pq}(X_t(q) - X_t(p)) \right) dt + 0 dW. \quad (22)$$

More generally, this method of conversion provides a means of testing whether a Liouvillian operator of interest corresponds to cylindrical or Q-Brownian motion in Hilbert space.

4. Duality

So far we have introduced two processes, one is a random vector of positions $\mathbf{q}(t)$ with (stochastic) dynamics described by Liouvillian \mathcal{L} , the other is a function X_t with (deterministic) dynamics described by adjoint Liouvillian \mathcal{L}^\dagger . We now connect these two processes via duality.

Suppose then that the processes are initialized with (non-random) vector $\mathbf{q}(0) = \mathbf{p}_m$ and function $X_0 = z$. We now connect these two processes with the expression $C(\mathbf{p}_m, z; t) = \langle \mathbf{p}_m | e^{\mathcal{L}^\dagger t} | z \rangle$. Although time dependence is present, we shall mostly use the expression $C(\mathbf{p}_m, z)$ unless time is explicitly analysed. On the one hand we find that

$$\begin{aligned} C(\mathbf{p}_m, z) &= \langle \mathbf{p}_m | \Psi(t) \rangle = \langle \mathbf{p}_m | \int \mathcal{D}x P[x; t] | x \rangle \\ &= \int \mathcal{D}x P[x; t] \prod_{i=1}^m x(p_i) = \mathbb{E}_X \left(\prod_{i=1}^m X_t(p_i) \right). \end{aligned} \quad (23)$$

Alternatively, we find that

$$C(\mathbf{p}_m, z) = \langle \chi(t) | z \rangle = \sum_{n=0}^{\infty} \int d\mathbf{q}_n \frac{f(\mathbf{q}_n, t)}{n!} \langle \mathbf{q}_n | z \rangle = \mathbb{E}_{\mathbf{q}}(z(\mathbf{q}(t))), \quad (24)$$

where we introduce the convention

$$z(\mathbf{q}) = \left(\prod_{i=1}^{|\mathbf{q}|} z(q_i) \right), \quad (25)$$

with $|\mathbf{q}|$ being defined as the length of vector \mathbf{q} .

In summary, we have established a duality between the particle process $\mathbf{q}(t)$ and the diffusion process X_t . Note that the expectation \mathbb{E}_X is an m^{th} order correlation function for a set of fixed positions \mathbf{p}_m . Conversely, $\mathbb{E}_{\mathbf{q}}$ is a nonlinear expectation, but does offer the freedom to choose z .

To calculate $C(\mathbf{p}_m, z)$, we can thus determine either expectation. We will see in subsequent sections that path integrals are one way of doing this. For the example above, a more direct approach is possible. From Eq. 22 we have a deterministic process

and the expectation \mathbb{E}_X is simply the product $\prod_{i=1}^m X_t(q_i)$, where X_t is the solution to the system

$$\begin{cases} \frac{\partial X_t(p)}{\partial t} &= D_p \nabla_p^2 X_t(p) + \int_{\mathcal{Y}} dq R_{pq}(X_t(p) - X_t(q)), \\ X_0(p) &= z. \end{cases} \quad (26)$$

If we take the homogeneous model, where $D_p = D$ is constant and $R_{pq} = R(p - q)$ just depends on separation, with the proviso that the total jump rate from any given position $R_{tot} = \int dr R(r) < \infty$ is finite, this equation is straightforwardly solved via Fourier transform techniques, where we find $X_t(p) = \mathcal{F}_p^{-1}(e^{(R_{tot} - q^2 D - \mathcal{F}_q(R(p)))t} \mathcal{F}_q(z(p)))$, where \mathcal{F}_q and \mathcal{F}_p^{-1} are Fourier and the inverse transforms, respectively. Then the duality condition implies expectation \mathbb{E}_q is just a product over these functions. This is to be expected; firstly, jump-diffusion is non-interacting, so independent across the m particles involved in the process, and secondly, the expected position will be dictated by the bias in the jumping function R_{pq} , and the diffusion of weight function z .

5. Stochastic Cable Equation and Path Integral Methods

In some cases, Feynman-Kac terms are needed to establish duality. This has been seen for discrete birth-death processes [44] via the Doi-Peliti formalism, and for spatially dependent processes [14, 15] using martingale techniques. In this section we develop path integral techniques to establish Feynman-Kac dualities for spatially dependent processes. This provides parallel techniques to establish results found in [14, 15] and generalise those of [44]. Furthermore, this machinery will enable perturbation analysis, meaning duality expectations can be decomposed into novel combinatorial forms. To highlight these methods, we start with a stochastic PDE in Hilbert space and search for a dual system of particle interactions.

5.1. Cable Equation and Dual Process

Consider then the following cable equation, which is a stochastic Nagumo equation used to model neuronal excitations [13, 40],

$$dX_t(p) = (\nabla_p^2 X_t - X_t)dt + dW_t, \quad (27)$$

where dW_t represents Q -Brownian motion. This has a Kolmogorov operator of the form (compare with Eq. 18)

$$\begin{aligned} (LG)(x) &= \langle \nabla_p^2 x - x, G_x(x) \rangle_H + \frac{1}{2} \text{Tr}(G_{xx}(x)Q) \\ &= DG(x)(\nabla_p^2(x)) - DG(x)(x) + \frac{1}{2} \sum_k \lambda_k D^2 G(x)(\xi_k)(\xi_k), \end{aligned} \quad (28)$$

where λ_k and ξ_k are eigenvalues and eigenfunctions of trace-class operator Q .

Next consider the operator defined by

$$\mathcal{L}^\dagger = \int_{\Upsilon} dp \psi_p^\dagger \nabla_p^2 \psi_p - \int_{\Upsilon} dp \psi_p^\dagger \psi_p + \iint_{\Upsilon^2} dp dq R_{pq} \psi_p^\dagger \psi_q^\dagger. \quad (29)$$

Then we find from Eq. 15 a Kolmogorov operator of the form

$$(LG)(x) = \int_{\Upsilon} dp \frac{\delta G}{\delta x_p} (\nabla_p^2(x) - x_p) + \iint_{\Upsilon^2} dp dq \frac{\delta^2 G}{\delta x_p \delta x_q} R_{pq}. \quad (30)$$

Now, if we define the symmetric function $R_{pq} = R(p, q) = \frac{1}{2} \sum_k \lambda_k \xi_k(p) \xi_k(q)$, we obtain Eq. 28.

Conversely, we can write the Liouvillian operator as $\mathcal{L} = \mathcal{L}' + V$, with operators

$$\begin{aligned} \mathcal{L}' &= \int_{\Upsilon} dp \psi_p^\dagger \nabla_p^2 \psi_p + \iint_{\Upsilon^2} dp dq R_{pq} (\psi_p \psi_q - \psi_p^\dagger \psi_q^\dagger \psi_p \psi_q), \\ V &= - \int_{\Upsilon} dp \psi_p^\dagger \psi_p + \iint_{\Upsilon^2} dp dq R_{pq} \psi_p^\dagger \psi_q^\dagger \psi_p \psi_q. \end{aligned} \quad (31)$$

Then \mathcal{L}' is the evolution operator of the diffusion-annihilation particle process

$$A_p + A_q \xrightarrow{R_{pq}} \phi, \quad A_p \xrightarrow{D_p}, \quad (32)$$

which represent particles pairwise annihilating at rate R_{pq} , and diffusing at rate D_p , where p and q represent the positions of the two annihilating particles. Note that the antisymmetric part of R_{pq} integrates to zero in Eq. 31 and we can assume R_{pq} is symmetric in its two arguments, which is also a natural assumption for the process.

Two processes have now been constructed; X_t is the cable process, which we initialize with some function z , and $\mathbf{q}(t)$ is the diffusion-annihilation process, starting from some vector \mathbf{p}_m . The two processes do not quite have adjoint evolution operators, so a little work is needed to construct duality.

5.2. Duality and Feynman-Kac Form

Duality is again constructed from $C(\mathbf{p}_m, z) = \langle \mathbf{p}_m | e^{\mathcal{L}^\dagger t} | z \rangle$, where on the one hand we have, $C(\mathbf{p}_m, z) = \mathbb{E}_X (X_t(\mathbf{p}_m))$ in exactly the same manner as Eq. 23.

To gain a dual expectation requires the derivation of a Feynman-Kac term. This is done via path integration, which requires the following resolution of the identity I (verifiable by showing $I | \mathbf{q}_n \rangle = | \mathbf{q}_n \rangle$ via the commutation relations of Eq. 1),

$$I = \sum_k \int_{\Upsilon^k} \frac{d\mathbf{r}_k}{k!} | \mathbf{r}_k \rangle \langle \mathbf{r}_k | = \int_{\hat{\Upsilon}} d\hat{\mathbf{r}} | \hat{\mathbf{r}} \rangle \langle \hat{\mathbf{r}} |. \quad (33)$$

The right hand side is notation to represent integration of vectors $\hat{\mathbf{r}}$ over the space $\hat{\Upsilon} = \cup_{k=0}^{\infty} \Upsilon^k$, so both coordinates and lengths of the vectors vary, introduced to simplify notation below. The resolutions of identity can then be used to interlace N time slices

of width ϵ , where we find

$$\begin{aligned}
 C(\mathbf{p}_m, z) &= \langle z | e^{(\mathcal{L}' + V)t} | \mathbf{p}_m \rangle = \langle z | \prod_{k=1}^N e^{(\mathcal{L}' + V)\epsilon} | \mathbf{p}_m \rangle \\
 &= \prod_{k=0}^N \int_{\hat{\mathbf{r}}} d\hat{\mathbf{r}}_k \langle z | \hat{\mathbf{r}}_N \rangle \prod_{\ell=1}^N \langle \hat{\mathbf{r}}_\ell | e^{\mathcal{L}'\epsilon + V\epsilon} | \hat{\mathbf{r}}_{\ell-1} \rangle \langle \hat{\mathbf{r}}_0 | \mathbf{p}_m \rangle \\
 &= \prod_{k=0}^N \int_{\hat{\mathbf{r}}} d\hat{\mathbf{r}}_k e^{\epsilon \sum_{i=1}^N V(\hat{\mathbf{r}}_i)} \langle z | \hat{\mathbf{r}}_N \rangle \prod_{\ell=1}^N \langle \hat{\mathbf{r}}_\ell | e^{\mathcal{L}'\epsilon} | \hat{\mathbf{r}}_{\ell-1} \rangle \langle \hat{\mathbf{r}}_0 | \mathbf{p}_m \rangle. \quad (34)
 \end{aligned}$$

Some observations help interpret this expression. Firstly, we have function $V(\hat{\mathbf{r}}) = -|\hat{\mathbf{r}}| + \sum_{i \neq j} R_{\hat{\mathbf{r}}_i \hat{\mathbf{r}}_j}$, which is found from the action of operator V on pure state kets $|\hat{\mathbf{r}}\rangle$. The distinction between operator V and function $V(\hat{\mathbf{r}})$ will hopefully be clear from the context it is found. Secondly, the term $\langle \hat{\mathbf{r}}_0 | \mathbf{p}_m \rangle$ reduces to delta functions via Eq. 1, so that integration over $\hat{\mathbf{r}}_0$ forces the initial condition $\hat{\mathbf{r}}_0 = \mathbf{p}_m$. Thirdly, also via Eq. 1, we get the term $\langle z | \hat{\mathbf{r}}_N \rangle = z(\hat{\mathbf{r}}_N)$. Fourthly, we note from Eq. 3 that $\langle \hat{\mathbf{r}}_\ell | e^{\mathcal{L}'\epsilon} | \hat{\mathbf{r}}_{\ell-1} \rangle$ is simply the probability density for transition from state $\hat{\mathbf{r}}_{\ell-1}$ to $\hat{\mathbf{r}}_\ell$ over a time-span of ϵ . Then $\prod_{\ell=1}^N \langle \hat{\mathbf{r}}_\ell | e^{\mathcal{L}'\epsilon} | \hat{\mathbf{r}}_{\ell-1} \rangle$ is just the joint probability density of the path $\hat{\mathbf{r}}_0 \rightarrow \hat{\mathbf{r}}_1 \rightarrow \dots \rightarrow \hat{\mathbf{r}}_N$ conditional on start vector $\hat{\mathbf{r}}_0 = \mathbf{p}_m$. Finally, in the continuum limit we formally write $P[\hat{\mathbf{r}}]$ for the density associated with the path $\hat{\mathbf{r}}(s)$, $s \in [0, t]$ and obtain path integral

$$\begin{aligned}
 C(\mathbf{p}_m, z) &= \int_{\hat{\mathbf{r}}(0)=\mathbf{p}_m} \mathcal{D}\hat{\mathbf{r}} P[\hat{\mathbf{r}}] z(\hat{\mathbf{r}}(t)) \exp \left\{ \int_0^t ds V(\hat{\mathbf{r}}(s)) \right\} \\
 &= \mathbb{E}_{\mathbf{q}} \left(z(\mathbf{q}(t)) \exp \left\{ \int_0^t ds V(\mathbf{q}(s)) \right\} \right). \quad (35)
 \end{aligned}$$

Note that this construction only works if pure states $|\hat{\mathbf{r}}\rangle$ are eigenstates of operator V . A sufficient condition is to require that V can be written as a function (or functional) of $\psi_q^\dagger \psi_q$, which is true for this example.

Thus we have duality $C(\mathbf{p}_m, z) = \mathbb{E}_X(X_t(\mathbf{p}_m)) = \mathbb{E}_{\mathbf{q}} \left(z(\mathbf{q}(t)) \exp \left\{ \int_0^t ds V(\mathbf{q}(s)) \right\} \right)$, where process X_t is initialized with $X_0 = z$ and process $\mathbf{q}(t)$ with $\mathbf{q}(0) = \mathbf{p}_m$. The expectation is complicated by the Feynman-Kac functional $\int_0^t ds V(\mathbf{q}(s))$ [8, 44] and although we have a form of duality, there is no duality function in the classical sense.

5.3. Coherent State Path Integration

Note that the path integral in the previous section is over paths taken by a vector $\hat{\mathbf{r}}(s)$ which varies in value and length. This is not the usual form of path integrals used for calculations in the Doi framework, which tend to be based on coherent states (or equivalently through the Bargmann-Fock space approach used by Peliti [29, 47]), which we now make use of. We next show that $C(\mathbf{p}_m, z)$ can be calculated exactly with the aid of a coherent state path integral [25]. This requires an alternative resolution of identity $I = \iint \mathcal{D}u \mathcal{D}v e^{-i \int_{\mathbf{r}} dq uv} |iv\rangle \langle u|$ to demarcate N time intervals of width ϵ . Note that this is a functional integral over real functions u and v (see Appendix in [25]). Then we

construct the following:

$$\begin{aligned}
 C(\mathbf{p}_m, z) &= \langle \mathbf{p}_m | e^{\mathcal{L}^\dagger t} | z \rangle = \langle \mathbf{p}_m | \prod_{k=1}^N e^{\mathcal{L}^\dagger \epsilon} | z \rangle \\
 &= \prod_{k=0}^N \iint \mathcal{D}u_k \mathcal{D}v_k e^{-i \sum_{k=0}^N \int_{\Upsilon} dq u_k v_k} \langle \mathbf{p}_m | i v_N \rangle \prod_{k=1}^N \langle u_k | e^{\mathcal{L}^\dagger \epsilon} | i v_{k-1} \rangle \langle u_0 | z \rangle \\
 &= \iint \mathcal{D}u \mathcal{D}v \prod_{j=1}^m [i v(p_j, t)] \exp \left\{ i \int_0^t ds \int_{\Upsilon} dq v \left(\nabla_q^2 u - u + \frac{\partial u}{\partial s} \right) \right. \\
 &\quad \left. - i \int_{\Upsilon} dq u(q, t) v(q, t) + \int_0^t ds \iint_{\Upsilon^2} dq dq' R_{qq'} u(q, s) u(q', s) \right\} \\
 &\quad \exp \left\{ \int_{\Upsilon} dq u(q, 0) z(q) \right\}. \tag{36}
 \end{aligned}$$

The last step makes use of eigenfunction properties of coherent states given in Eq. 8 to form the final path integral. For example, if \mathcal{L}^\dagger is in normal form, $\langle u_k | \mathcal{L}^\dagger(\psi_q^\dagger, \psi_q) | i v_{k-1} \rangle = \langle u_k | i v_{k-1} \rangle \mathcal{L}^\dagger(u_k(q), i v_{k-1}(q)) = e^{i \int_{\Upsilon} dq u_k v_{k-1}} \mathcal{L}^\dagger(u_k(q), i v_{k-1}(q))$. Note that variables u and v in the final path integral are integrated over both time t and space q .

This can now be treated perturbatively. The terms $\prod_{j=1}^m [i v(p_j, t)]$ will correspond to m termination nodes in a perturbative expansion Feynman diagram (see Fig. 1), and expanding $e^{\int_{\Upsilon} dq u(q, 0) z(q)}$ will result in any number of initiating nodes with coefficient $z(q)$. There will be no internal nodes as the remaining part of the path integral can be calculated directly and absorbed into propagators by using a generating functional of the form

$$\begin{aligned}
 Z(J, K) &= \iint \mathcal{D}u \mathcal{D}v \exp \left\{ i \int_0^t ds \int_{\Upsilon} dq v \left(\nabla_q^2 u - u + \frac{\partial u}{\partial s} \right) \right. \\
 &\quad \left. - i \int_{\Upsilon} dq u(q, t) v(q, t) + \int_0^t ds \iint_{\Upsilon^2} dq dq' R_{qq'} u(q, s) u(q', s) \right. \\
 &\quad \left. + \int_0^t ds \int_{\Upsilon} dq (uJ + ivK) \right\}. \tag{37}
 \end{aligned}$$

Now, integrating over the v variable gives delta functionals that restrict u to a form obeying

$$\begin{cases} -\frac{\partial u(q, s)}{\partial s} = \nabla_q^2 u - u + K, \\ u(q, t) = 0. \end{cases}$$

Thus we have a reverse time heat equation which can be solved with standard techniques. Note that the space Υ has not yet been specified. Although this equation can be solved in \mathbb{R}^n , results in \mathbb{R} are largely similar, where we find [19]

$$u(q, t) = \int_{\tau}^t ds \int_{\mathbb{R}} dr \frac{1}{\sqrt{4\pi(s-\tau)}} \exp \left\{ -\frac{(q-r)^2}{4(s-\tau)} \right\} K(r, s) e^{-(s-\tau)}, \tag{38}$$

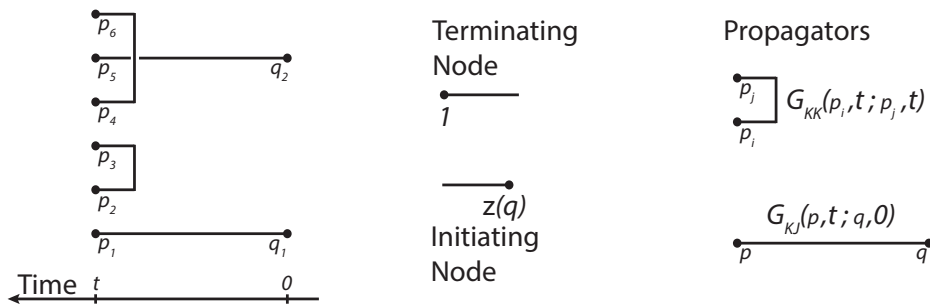

Figure 1. Feynman diagram information for duality function $C(\mathbf{p}_m, z)$ of the cable equation. A sample diagram, initiating and terminating node types, and associated propagators are provided.

and we find a generating functional of the form

$$Z(J, K) = \exp \left\{ \int_0^t ds \iint_{\mathbb{R}^2} dq dq' R_{qq'} u(q, s) u(q', s) + \int_0^t ds \int_{\mathbb{R}} dq u(q, s) J(q, s) \right\}. \quad (39)$$

Thus we find that there are two non-zero propagators that relate to initiating or terminating nodes in the corresponding Feynman diagrams. Specifically,

$$\begin{aligned} G_{KK}(p_i, t; p_j, t) &= \iint \mathcal{D}u \mathcal{D}v iv(p_i, t) iv(p_j, t) e^S = \frac{\delta^2 Z(J, K)}{\delta K(p_i, t) \delta K(p_j, t)} \Big|_{J=K=0} \\ &= 2 \int_0^t ds \iint_{\mathbb{R}^2} dr dr' \frac{R_{rr'}}{4\pi s} \exp \left\{ \frac{-(p_i - r)^2 - (p_j - r')^2}{4s} \right\} e^{-2s} \\ G_{KJ}(p, t; q, 0) &= \iint \mathcal{D}u \mathcal{D}v iv(p, t) u(q, 0) e^S = \frac{\delta^2 Z(J, K)}{\delta K(p, t) \delta J(q, 0)} \Big|_{J=K=0} \\ &= \frac{1}{\sqrt{4\pi t}} \exp \left\{ \frac{-(p - q)^2}{4t} \right\} e^{-t}, \end{aligned} \quad (40)$$

where S is the action, that is, the first exponent of the path integral in Eq. 36. Note that the first propagator is just a time weighted diffusion of the function $R_{p_i p_j} \equiv R(p_i, p_j)$ in both coordinates, and corresponds to the arced edges in Fig. 1. An arc connecting p_i to p_j thus has an associated factor $2 \int_0^t ds e^{-2s} (\Phi_s^1 \Phi_s^2 R)(p_i, p_j)$, where $\Phi_s^k R$ represents the diffusion operator acting on coordinate k of function R .

The second propagator is a time weighted heat kernel, and is associated with initiating nodes which have a factor of the form $z(q)$ where position q is integrated over. Thus a horizontal line in Fig. 1 terminating in p_i has a contribution of the form

$$\int_{\mathbb{R}} dq z(q) G_{KJ}(p_i, t; q, 0) = \int_{\mathbb{R}} dq \frac{z(q)}{\sqrt{4\pi t}} \exp \left\{ \frac{-(p_i - q)^2}{4t} \right\} e^{-t} = e^{-t} (\Phi_t z)(p_i), \quad (41)$$

where $\Phi_t z$ represents the diffusion operator acting on function z .

Finally, summing over all possible diagrams, we find

$$C(\mathbf{p}_m, z) = \sum_{P \subset \{1, 2, \dots, m\}} \prod_{\{i, j\} \in P} 2 \int_0^t ds e^{-2s} (\Phi_s^1 \Phi_s^2 R)(p_i, p_j) \prod_{k \in P^c} e^{-t} (\Phi_t z)(p_k), \quad (42)$$

where the (evenly sized) subsets P are those containing non-intersecting pairs of distinct elements from the set $\{1, 2, \dots, m\}$.

Note that the order one correlation function $C(p, z) = e^{-t}(\Phi_t z)(p)$ is just a simple diffusion of z , as can be seen by taking the expectation of Eq. 27.

5.4. Dynamic Duality Equations

The previous section saw a path integral approach to the calculation of $C(\mathbf{p}_m, z; t) = \langle \mathbf{p}_m | e^{\mathcal{L}^\dagger t} | z \rangle$. However, we can also derive two dynamic equations for $C(\mathbf{p}_m, z; t)$. Differentiating, we find

$$\frac{\partial C}{\partial t} = \langle \mathbf{p}_m | e^{\mathcal{L}^\dagger t} \mathcal{L}^\dagger | z \rangle = \langle z | e^{\mathcal{L} t} \mathcal{L} | \mathbf{p}_m \rangle. \quad (43)$$

Now on the one hand we can let \mathcal{L} act on pure state $|\mathbf{p}_m\rangle$ to give (via the commutation relations in Eq. 1),

$$\frac{\partial C}{\partial t} = \nabla_{\mathbf{p}_m}^2 C - mC + \sum_{i \neq j} R_{p_i p_j} C(\mathbf{p}_m^{-(i,j)}, z; t), \quad (44)$$

where $\mathbf{p}_m^{-(i,j)}$ is the vector \mathbf{p}_m with components i and j removed. Thus we have a BBGKY like hierarchy of finite dimensional heat equations. Note that unlike many BBGKY hierarchies, the equation for $C(\mathbf{p}_m, z)$ implicates the function $C(\mathbf{p}_m^{-(i,j)}, z)$ which depends upon a smaller vector $\mathbf{p}_m^{-(i,j)}$, meaning these equations could be treated recursively.

Alternatively, we can let \mathcal{L}^\dagger act on coherent state $|z\rangle$ to give (via the eigenstate relations in Eq. 8),

$$\frac{\partial C}{\partial t} = \int_{\mathcal{R}} dq \frac{\delta C}{\delta z_q} (\nabla_q^2(z) - z) + \iint_{\mathcal{R}^2} dq dq' \frac{\delta^2 C}{\delta z_q \delta z_{q'}} R_{qq'}. \quad (45)$$

Thus we have essentially recovered the Fokker-Plank equation corresponding to Eq. 30, albeit with different initial conditions; Eq.s 44 and 45 both have initial condition $C(\mathbf{p}_m, z; 0) = z(\mathbf{p}_m)$.

So to analyse the duality expectations such as $C(\mathbf{p}_m, z; t)$, one can either treat them dynamically to extract differential equations, or try a path integral approach.

6. Simple Decay with Fermionic Duality Mechanism

We next consider a situation where a Feynman-Kac correction is not sufficient to extract a duality relationship, and fermionic approaches are needed to deal with unwanted negative signs in evolution operators, producing novel dualities.

Consider the following stochastic PDE for Brownian motion in Hilbert space H

$$dX_t(p) = -\gamma_p X_t(p)^2 dt + B(X_t) dW_t(p), \quad (46)$$

where we have Q-Brownian motion dW_t , a positive, position dependent decay function γ_p , and initial function $X_0 = z$. For this example we have non-trivial noise, with linear operator $B(X_t)$ defined by its action on the Q eigenfunctions, where we have $B(X_t)(\xi_k)(p) = \sum_m \beta_{km}(X_t)\xi_m(p)$, where we will later specify functionals $\beta_{km}(X_t)$.

This example has been chosen because firstly the negative term will be shown to preclude any obvious duality with a particle process under the framework of previous sections, and secondly the noise term is not a relatively simple point-wise operator of the form $(B(X_t)\xi_k)(p) = b(X_t(p))\xi_k(p)$. That is, $B(X_t)(\xi_k)(p)$ depends globally on the function X_t , not just on the value $X_t(p)$.

Then this gives us a Kolmogorov operator of the form:

$$\begin{aligned} (LG)(x) &= \langle -\gamma_p x^2, G_x(x) \rangle + \frac{1}{2} \text{Tr}(G_{xx} B(x) Q B(x)^*) \\ &= - \int_{\Upsilon} dp \frac{\delta G}{\delta x_p} \gamma_p x_p^2 + \frac{1}{2} \iint_{\Upsilon^2} dp dq \frac{\delta^2 G}{\delta x_p \delta x_q} \sum_{k,m,n} \lambda_k \beta_{km}(x) \beta_{kn}(x) \xi_m(p) \xi_n(q). \end{aligned} \quad (47)$$

To connect this operator via Eq. 15 to an adjoint Liouvillian operator \mathcal{L}^\dagger , we introduce

$$\mathcal{L}^\dagger = - \int_{\Upsilon} dp \gamma_p \psi_p^\dagger \psi_p^2 + \iiint_{\Upsilon^3} dp dq dr R_{pqr} \psi_p^\dagger \psi_q^\dagger \psi_r. \quad (48)$$

Now, much like the previous section, we can compensate the second term to get a dual particle process with Liouvillian $\mathcal{L}' = \mathcal{L} - V$ for a suitable term V . However, the negative sign of the first term in Eq. 48 means a compensating term of the form $\int dp \gamma_p \psi_p^\dagger \psi_p$ has a positive sign. This means that although the requisite equation $\langle 1 | \mathcal{L}' = \langle 1 | (- \int_{\Upsilon} dp \gamma_p ((\psi_p^\dagger)^2 \psi_p - \psi_p^\dagger \psi_p) + \dots) = 0$ is satisfied, and ensures total probability conservation for the dual particle process, the corresponding master equation has the wrong sign and the associated ‘probabilities’ are not necessarily positive.

Instead, following [44], we introduce an operator to flip the sign. This stems from algebraic probability arguments in [44], however, we will see this can also be framed in terms of a fermionic Doi algebra [26].

Specifically, we introduce the self-adjoint operator $b = a + a^\dagger$ where a and its adjoint a^\dagger are standard Pauli operators acting on the two dimensional space $\{|0\rangle, |1\rangle\}$, satisfying standard anticommutativity relations $\{a, a^\dagger\} = 1$ and $\{a, a\} = \{a^\dagger, a^\dagger\} = 0$. We also introduce orthonormal states $|\pm\rangle = \frac{1}{2}(|0\rangle \pm |1\rangle)$, where we note that $b|\pm\rangle = \pm|\pm\rangle$.

Next we replace the Liouvillian in Eq. 48 with

$$\mathcal{L}^\dagger = \int_{\Upsilon} dp \gamma_p b \psi_p^\dagger \psi_p^2 + \iiint_{\Upsilon^3} dp dq dr R_{pqr} \psi_p^\dagger \psi_q^\dagger \psi_r, \quad (49)$$

and introduce dynamics $|\Psi_t\rangle = e^{\mathcal{L}^\dagger t} |\Psi_0\rangle$ for some initial state $|\Psi_0\rangle$, where, analogous to Eq. 9, the states have a representation of the form

$$|\Psi_t\rangle = \int \mathcal{D}x P[x; t] |x, -\rangle. \quad (50)$$

Note that strictly speaking the state $|x, -\rangle$ is shorthand for the tensor product $|x\rangle \otimes |-\rangle \in H \otimes \{\pm\}$, and the operators ψ_p and b commute because they act independently on H and $\{\pm\}$. Shorthand rather than formal notation is used throughout.

Now, direct calculation shows us that for generic bra $\langle g|$ and functional $G(x) = \langle g|x, -\rangle$,

$$\begin{aligned} \langle g| \frac{\partial}{\partial t} \int \mathcal{D}x P[x; t] |x, -\rangle &= \frac{\partial}{\partial t} \int \mathcal{D}x P[x; t] G(x) = \int \mathcal{D}x P[x; t] \langle g| \mathcal{L}^\dagger |x, -\rangle = \\ &= \int \mathcal{D}x P[x; t] \left\{ - \int_{\Upsilon} dp \frac{\delta G}{\delta x_p} \gamma_p x_p^2 + \iint_{\Upsilon^2} dp dq \frac{\delta^2 G}{\delta x_p \delta x_q} \int_{\Upsilon} dr R_{pqr} x_r \right\}. \end{aligned} \quad (51)$$

Thus we obtain the Fokker-Planck equation corresponding to the Kolmogorov operator given in Eq. 47, provided we have the match

$$\int_{\Upsilon} dr R_{pqr} x_r = \frac{1}{2} \sum_k \lambda_k (B(x)\xi_k)(p) (B(x)\xi_k)(q). \quad (52)$$

This offers a wide choice for R_{pqr} . Note that the right hand side dictates that R_{pqr} needs to be symmetric in p and q (which will be seen below to also be a natural assumption for a dual particle interaction). To specify R_{pqr} in terms of operator B the orthonormal basis ξ_k can be used. Firstly, write $\int_{\Upsilon} dr R_{pqr} x_r = \sum_{m,n} \alpha_{mn}(x) \xi_m(p) \xi_n(q)$ for coefficients $\alpha_{mn}(x)$, which are also functionals in x . Secondly, we have the earlier assumption that $(B(x)\xi_k)(p) = \sum_m \beta_{km}(x) \xi_m(p)$ for functional coefficients $\beta_{km}(x)$. Then using orthonormality, Eq. 52 reduces to equivalent condition

$$\alpha_{mn}(x) = \frac{1}{2} \sum_k \lambda_k \beta_{km}(x) \beta_{kn}(x), \quad (53)$$

and the action of R_{pqr} on x_r can be specified in terms of the action of $B(x)$ on the eigenfunctions.

Next for a dual process, we consider the following particle model. We again have particles A_p at position p , but now also an overall system-wide state sign $\kappa \in \{\pm\}$. Then we have process

$$\begin{aligned} A_p &\longrightarrow A_p + A_p, & \kappa &\longrightarrow -\kappa, & (\text{rate } \gamma_p) \\ A_p + A_q &\longrightarrow A_r, & \kappa &\longrightarrow \kappa. & (\text{rate } R_{pqr}) \end{aligned} \quad (54)$$

Thus we have localised particle fission with sign flip, and a non-local pairwise amalgamation process that preserves the system sign. The state of the system (\mathbf{q}, κ) is next represented by a ket $|\mathbf{q}, \kappa\rangle$. This has a corresponding Liouvillian $\mathcal{L}' = \mathcal{L} - V$ of the form

$$\mathcal{L}' = \int_{\Upsilon} dp \gamma_p (b(\psi_p^\dagger)^2 \psi_p - \psi_p^\dagger \psi_p) + \iiint_{\Upsilon^3} dp dq dr R_{pqr} (\psi_r^\dagger \psi_p \psi_q - \psi_p^\dagger \psi_q^\dagger \psi_p \psi_q), \quad (55)$$

where $V = \int_{\Upsilon} dp \gamma_p \psi_p^\dagger \psi_p + \iiint_{\Upsilon^3} dp dq dr R_{pqr} \psi_p^\dagger \psi_q^\dagger \psi_p \psi_q$. This results in an evolution equation $|\chi_t\rangle = e^{\mathcal{L}'t} |\chi_0\rangle$ for a designated initial state $|\chi_0\rangle = |\mathbf{p}_m, -\rangle$.

Then analogous to [44], we obtain the duality

$$C(\mathbf{p}_m, z) = \langle \mathbf{p}_m, -|e^{\mathcal{L}^\dagger t}|z, - \rangle = \mathbb{E}_X (X_t(\mathbf{p}_m)) = \mathbb{E}_{(\mathbf{q}, \kappa)} \left(z(\mathbf{q}(t)) \mathbb{I}_{\{\kappa(t) \equiv -\}} e^{\int_0^t ds V(\mathbf{q}(s))} \right). \quad (56)$$

The last term in this expression is derived in much the same way as Eq. 34, except that the resolution of identity in this case is $I = \sum_{\kappa \in \{\pm\}} \int_{\hat{\mathbf{r}}} d\hat{\mathbf{r}} |\hat{\mathbf{r}}, \kappa\rangle \langle \hat{\mathbf{r}}, \kappa|$. The main difference in the subsequent derivation is that the term $\langle x | \hat{\mathbf{r}}_N \rangle$ in Eq. 34 becomes $\langle z, - | \hat{\mathbf{r}}_N, \kappa_N \rangle = \langle z | \hat{\mathbf{r}}_N \rangle \mathbb{I}_{\{\kappa_N \equiv -\}}$ resulting in the form above.

To calculate the expectations one can again use path integrals. We can firstly calculate the expectation $\mathbb{E}_X (X_t(\mathbf{p}_m)) = \langle \mathbf{p}_m, -|e^{\mathcal{L}^\dagger t}|z, - \rangle$ in Eq. 56, which uses the Liouvillian operator given in Eq. 49. This involves the operator $b = a + a^\dagger$, which would implicate a hybrid path integral containing grassmannians [26] and bosonic integrals [25]. Alternatively, we can use the original operator in Eq. 48 to construct a path integral for expectation $\mathbb{E}_X (X_t(\mathbf{p}_m)) = \langle \mathbf{p}_m | e^{\mathcal{L}^\dagger t} | z \rangle$, which will not involve grassmanians. Because both diffusion processes labelled $X_t(\mathbf{p}_m)$ have the same Fokker-Planck equation and so distribution, the expectation $\mathbb{E}_X (X_t(\mathbf{p}_m))$ will be the same in both cases, so using the path integral without grassmannians will be simpler.

7. Particle-Particle and Diffusion-Diffusion Dualities

Thus far, we have focused on cases where a particle model is dual to a diffusion model. Next, self-dualities are considered, that is, duality between two stochastic processes of a single type. Such duality has been studied extensively; details covering a range of stochastic process types can be found in [10, 22, 24]. We consider two cases; particle models dual with particle models and Hilbert space diffusions dual with Hilbert space diffusions.

7.1. Particle-Particle Models

Consider then, dualities between pairs of particle models. Such duality has been reported previously. The classic example of Karlin and McGregor is duality between a reflecting and an absorbing birth-death process [32]. Here absorbing can, for example, be interpreted as an empty population remaining empty, and reflecting taken to mean births arising from an empty population. The duality consists of a simple exchange of the role of birth and death in the associated parameters, and can be interpreted with a Siegmund duality function [2, 52]. Dualities of this nature have seen a range of generalisations (such as [2, 16], for example), although not explicitly for pairs of spatially dependent birth-death processes, or using Doi-Peliti path integral formalism, which we next consider.

For the first of two dual processes, consider a simple particle model for budding-birth-death, where the parent particle survives (non-local) birth of a daughter particle,

$$A_p \xrightarrow{\mu_p} \emptyset, \quad A_p \xrightarrow{\beta_{pq}} A_p + A_q. \quad (57)$$

Note that this system is absorbing in the sense that if a population is empty it remains so. This system has an evolution operator of the form

$$\mathcal{L}' = \int_{\Upsilon} dp \mu_p (\psi_p - \psi_p^\dagger \psi_p) + \iint_{\Upsilon^2} dp dq \beta_{pq} (\psi_p^\dagger \psi_q^\dagger \psi_p - \psi_p^\dagger \psi_p), \quad (58)$$

resulting in state evolution equation $|\chi_t\rangle = e^{\mathcal{L}'t} |\chi_0\rangle$, where we assume initial (pure) state $|\chi_0\rangle = |\mathbf{p}_m\rangle$. The current state also has probabilistic interpretation $|\chi_t\rangle = \sum_k \int_{\Upsilon^k} \frac{d\mathbf{r}_k}{k!} f_{\text{BBD}}(\mathbf{r}_k) |\mathbf{r}_k\rangle = \int_{\hat{\Upsilon}} d\hat{\mathbf{r}} f_{\text{BBD}}(\hat{\mathbf{r}}) |\hat{\mathbf{r}}\rangle$. Here, f_{BBD} is the probability density for the budding-birth-death process.

For the second process, take the natural dual to Eq. 57, the spontaneous-birth-assassination process

$$\emptyset \xrightarrow{\mu_p} A_p, \quad A_p + A_q \xrightarrow{\beta_{pq}} A_p. \quad (59)$$

Note that this is reflecting, in the sense that if the system arrives at the empty state, rebirth into a positive population will occur. The model can be described by evolution operator

$$\mathcal{L}^\dagger = \int_{\Upsilon} dp \mu_p (\psi_p^\dagger - 1) + \iint_{\Upsilon^2} dp dq \beta_{pq} (\psi_p^\dagger \psi_p \psi_q - \psi_p^\dagger \psi_q^\dagger \psi_p \psi_q). \quad (60)$$

This similarly results in a state evolution equation, $|\Psi_t\rangle = e^{\mathcal{L}^\dagger t} |\Psi_0\rangle$, where we have initial state $|\Psi_0\rangle = |\mathbf{q}_n\rangle$ and current state $|\Psi_t\rangle = \int_{\hat{\Upsilon}} d\hat{\mathbf{r}} f_{\text{SBA}}(\hat{\mathbf{r}}) |\hat{\mathbf{r}}\rangle$. Here, f_{SBA} is the probability density for the spontaneous-birth-assassination process.

Now these operators are connected by $\mathcal{L} = \mathcal{L}' + V$ where we have self-adjoint operator

$$V = \int_{\Upsilon} dp \mu_p (\psi_p^\dagger \psi_p - 1) + \iint_{\Upsilon^2} dp dq \beta_{pq} (\psi_p^\dagger \psi_p - \psi_p^\dagger \psi_q^\dagger \psi_p \psi_q). \quad (61)$$

Note that we have the implicit assumption that $\int_{\Upsilon} dp \mu_p < \infty$. This will ensure the total spontaneous birth rate is finite and no population explosion occurs.

Then to construct a duality we use the function $C(\mathbf{p}_m, \mathbf{q}_n) = \langle \mathbf{p}_m | e^{\mathcal{L}^\dagger t} | \mathbf{q}_n \rangle$. On the one hand, using Eq. 3, we have

$$C(\mathbf{p}_m, \mathbf{q}_n) = \langle \mathbf{p}_m | \Psi_t \rangle = \langle \mathbf{p}_m | \int_{\hat{\Upsilon}} d\hat{\mathbf{r}} f_{\text{SBA}}(\hat{\mathbf{r}}) |\hat{\mathbf{r}}\rangle = f_{\text{SBA}}(\mathbf{p}_m), \quad (62)$$

which is just the density at \mathbf{p}_m for the spontaneous-birth-assassination particle process starting at \mathbf{q}_n . More explicitly we write $f_{\text{SBA}}(\mathbf{p}_m) = f_{\text{SBA}}(\hat{\mathbf{r}}(t) = \mathbf{p}_m | \hat{\mathbf{r}}(0) = \mathbf{q}_n)$.

Conversely, following the approach to derive Eq. 35, a Feynman-Kac expectation of the following form is obtained, where

$$C(\mathbf{p}_m, \mathbf{q}_n) = \langle \mathbf{q}_n | e^{\mathcal{L}t + Vt} | \mathbf{p}_m \rangle = \int_{\hat{\mathbf{r}}(0)=\mathbf{p}_m}^{\hat{\mathbf{r}}(t)=\mathbf{q}_n} \mathcal{D}\hat{\mathbf{r}} P[\hat{\mathbf{r}}] e^{\int_0^t ds V(\hat{\mathbf{r}}(s))}, \quad (63)$$

and

$$V(\hat{\mathbf{r}}) = \left(\sum_{i=1}^{|\hat{\mathbf{r}}|} \mu_{\hat{\mathbf{r}}_i} - \int_{\Upsilon} dp \mu_p \right) - \left(\sum_{\substack{i,j=1 \\ i \neq j}}^{|\hat{\mathbf{r}}|} \beta_{\hat{\mathbf{r}}_i \hat{\mathbf{r}}_j} - \sum_{i=1}^{|\hat{\mathbf{r}}|} \int_{\Upsilon} dp \beta_{\hat{\mathbf{r}}_i p} \right). \quad (64)$$

Note that the first term is the variation in death rate, the second term is the covariation in birth rate, with V representing variation of population decline for the budding-birth-death process.

Now, the path integral in Eq. 63 is a sum of paths for vectors $\hat{\mathbf{r}}(s), s \in [0, t]$ (arising from the budding-birth-death process) with a specified start and end vector. The main difference from the derivation of Eq. 35 is that the ket $|z\rangle$ is replaced with $|\mathbf{q}_n\rangle$ resulting in the extra boundary condition $\hat{\mathbf{r}}(t) = \mathbf{q}_n$. A similar construction gives $\langle \mathbf{q}_n | e^{\mathcal{L}'t} | \mathbf{p}_m \rangle = f_{BBD}(\mathbf{q}_n) = \int_{\hat{\mathbf{r}}(0)=\mathbf{p}_m}^{\hat{\mathbf{r}}(t)=\mathbf{q}_n} \mathcal{D}\hat{\mathbf{r}} P[\hat{\mathbf{r}}]$, where we write $f_{BBD}(\mathbf{q}_n)$ for the probability density at \mathbf{q}_n of the budding-birth-death process starting at \mathbf{p}_m . Note in particular that the sum of the probability density functional $P[\hat{\mathbf{r}}]$ over all paths $\hat{\mathbf{r}}$ is restricted by the paths endpoints, and does not sum to unity in this case. Then normalising correctly, we obtain an expectation over paths with fixed termini,

$$\mathbb{E}_{BBD} \left(\exp \left\{ \int_0^t ds V(\hat{\mathbf{r}}(s)) \right\} \middle| \begin{matrix} \hat{\mathbf{r}}(t)=\mathbf{q}_n, \\ \hat{\mathbf{r}}(0)=\mathbf{p}_m \end{matrix} \right) = \frac{\int_{\hat{\mathbf{r}}(0)=\mathbf{p}_m}^{\hat{\mathbf{r}}(t)=\mathbf{q}_n} \mathcal{D}\hat{\mathbf{r}} P[\hat{\mathbf{r}}] e^{\int_0^t ds V(\hat{\mathbf{r}}(s))}}{\int_{\hat{\mathbf{r}}(0)=\mathbf{p}_m}^{\hat{\mathbf{r}}(t)=\mathbf{q}_n} \mathcal{D}\hat{\mathbf{r}} P[\hat{\mathbf{r}}]}, \quad (65)$$

resulting in the following duality, with a Feynman-Kac term written as the ratio of reciprocal densities,

$$\mathbb{E}_{BBD} \left(\exp \left\{ \int_0^t ds V(\hat{\mathbf{r}}(s)) \right\} \middle| \begin{matrix} \hat{\mathbf{r}}(t)=\mathbf{q}_n, \\ \hat{\mathbf{r}}(0)=\mathbf{p}_m \end{matrix} \right) = \frac{f_{SBA}(\hat{\mathbf{r}}(t) = \mathbf{p}_m | \hat{\mathbf{r}}(0) = \mathbf{q}_n)}{f_{BBD}(\hat{\mathbf{r}}(t) = \mathbf{q}_n | \hat{\mathbf{r}}(0) = \mathbf{p}_m)}. \quad (66)$$

In general for particle models, although the condition $\langle 1 | \mathcal{L} = 0$ is satisfied, the dual condition $\langle 1 | \mathcal{L}^\dagger = 0$ is not and a Feynman-Kac correction will be needed to establish duality. However, dualities between pairs of particle models can be constructed in the manner above.

7.2. Diffusion-Diffusion Models

Next we consider dualities between pairs of diffusion models. This kind of duality has been considered previously [10, 22, 24], although seemingly not for diffusion in function space, or with Doi-Peliti formalism, which we now discuss. We consider two cases, depending on whether the noise is cylindrical or Q -Brownian motion.

Firstly, consider the diffusion given by the following stochastic PDE, where dW_t is cylindrical Brownian motion in H , and the process X_t is initialized with function $X_0 = x$,

$$dX_t(p) = (\nabla_p^2 X_t(p) - X_t(p) + R_p X_t(p)^2) dt + \omega_p X_t(p) dW_t(p). \quad (67)$$

Thus we have two terms from the cable equation, a geometric noise term and a quadratic drift term. Then this process has a corresponding Liouvillian operator of the form

$$\mathcal{L}^\dagger = \int_{\Upsilon} dp \psi_p^\dagger (\nabla_p^2 - 1) \psi_p + \int_{\Upsilon} dp R_p \psi_p^\dagger \psi_p^2 + \int_{\Upsilon} dp \frac{\omega_p^2}{2} (\psi_p^\dagger)^2 \psi_p^2. \quad (68)$$

That is, we have evolution $|\Psi_t\rangle = \int \mathcal{D}z P_X(z, t) |z\rangle = e^{\mathcal{L}^\dagger t} |\Psi_0\rangle = e^{\mathcal{L}^\dagger t} |x\rangle$ of initial state $|x\rangle$.

Next the operator \mathcal{L} will be used to generate a dual process. The first term in \mathcal{L}^\dagger is self-adjoint so results in identical drift terms in the corresponding stochastic PDE for \mathcal{L} . For the middle term of \mathcal{L} , we get $\int_{\Upsilon} dp R(p) (\psi_p^\dagger)^2 \psi_p$ which contributes cylindrical Brownian motion rather than a drift term. Combining with the third (self-adjoint) term results in the following process Y_t , initiated with some function $Y_0 = y$,

$$dY_t(p) = (\nabla_p^2 Y_t(p) - Y_t(p)) dt + \sqrt{Y_t(p)(2R_p + \omega_p^2 Y_t(p))} dW_t(p). \quad (69)$$

Thus we have evolution $|\chi_t\rangle = \int \mathcal{D}z P_Y(z, t) |z\rangle = e^{\mathcal{L}t} |\chi_0\rangle = e^{\mathcal{L}t} |y\rangle$ of initial state $|y\rangle$.

Then, to construct duality, we consider the function $C(y, x) = \langle y | e^{\mathcal{L}^\dagger t} | x \rangle$ formed from the bracket of two coherent states formed from the functions x and y . Then recalling the product of two coherent states takes the form $\langle x | y \rangle = e^{\int_{\Upsilon} dp xy}$ we find, in much the same way as previous sections, that

$$C(y, x) = \mathbb{E}_X \left(e^{\int_{\Upsilon} dp X_t(p) y(p)} \right) = \mathbb{E}_Y \left(e^{\int_{\Upsilon} dp x(p) Y_t(p)} \right). \quad (70)$$

If one attempts similar things with a Q -Brownian process, things become a little more awkward. Take for example,

$$dX_t(p) = \left(\nabla_p^2 X_t(p) - X_t(p) + X_t(p) \int_{\Upsilon} dq R_{pq} X_t(q) \right) dt + X_t(p) dW_t(p). \quad (71)$$

This process generalizes the process above, with the choice $R_{pq} = R_p \delta(p - q)$ recovering the drift term in Eq. 67. The process has a Liouvillian of the form,

$$\mathcal{L}^\dagger = \int_{\Upsilon} dp \psi_p^\dagger (\nabla_p^2 - 1) \psi_p + \iint_{\Upsilon^2} dp dq R_{pq} \psi_p^\dagger \psi_p \psi_q + \iint_{\Upsilon^2} dp dq \frac{\Omega_{pq}}{2} \psi_p^\dagger \psi_q^\dagger \psi_p \psi_q, \quad (72)$$

where $\Omega_{pq} = \sum_k \lambda_k \xi_k(p) \xi(q)$.

Now the first and third terms are self-adjoint. Thus for $R_{pq} = 0$ we can use the construction above to get a self-dual process with duality function $e^{\int_{\Upsilon} dp xy}$. However, the lack of symmetry between p and q in the second term $\iint_{\Upsilon^2} dp dq R_{pq} \psi_p^\dagger \psi_p \psi_q$ means that the adjoint does not correspond to a Q -Brownian motion term, and duality with another diffusion is not forthcoming. Note that if we subtract $\iint_{\Upsilon^2} dp dq R_{pq} \psi_p^\dagger \psi_q^\dagger \psi_p \psi_q$ from the second term and add it to the third we can construct a dual particle process with a Feynman-Kac term, much in the same way as Eq. 31, so some form of duality is still possible.

8. Conclusions

The construction of dualities between stochastic processes is achievable for a range of processes utilizing many techniques. In particular, it is possible to construct dualities between spatially dependent birth-death processes and diffusion on function spaces [14, 15]. These birth-death processes can incorporate mutation, selection, spatial diffusion and other geneological structures. The methods involved are martingale

techniques and have been applied to analyse asymptotic behaviours and ergodicity. Doi-Peliti field theoretic methods have been used to construct dualities between (non-spatial) birth-death processes and one dimensional diffusions [44]. In this work we have accomplished three things. Firstly, we have shown that Doi-Peliti methods can be extended to infinite dimensions, establishing path integral methods to construct some dualities seen in [14, 15]. The method adopts a continuous path integral formulation (similar to Doi's original work [17, 18]) rather than a lattice based approach (such as that of Peliti [47]). This formalism enables interpretation of stochastic differential equations involving cylindrical or Q -Brownian motion, a subject not covered in [14, 15]. These methods also yield some self-dualities for these processes. Secondly, path integral perturbation methods reveal novel combinatorial forms for duality functions, which arise naturally as correlation functions. Thirdly, the inclusion of fermionic techniques results in dualities not currently found by other means. The Doi-Peliti path integral formalism is thus shown to be a useful tool in the pursuit of dualities, and finding extensions of these methods and subsequent applications warrants further study.

In terms of models, we find that a particle process of the form $A_p \longrightarrow \dots$ will give rise to a drift term in the dual diffusion process, and a process of the form $A_p + A_q \longrightarrow \dots$ will give rise to a Brownian motion term. Furthermore a local process such as $A_p + A_p \longrightarrow \dots$ will correspond to cylindrical Brownian motion, whereas a non-local process such as $A_p + A_q \longrightarrow \dots$ will correspond to Q -Brownian motion. This naturally raises the question of whether there are dualities of interest for more complex particle processes such as $A_p + A_q + A_r \longrightarrow \dots$. The corresponding Fokker-Planck equation will have third order differentials, suggesting if a dual stochastic process exists, it is not Brownian motion. Indeed any such dual 'process' may not be stochastic. We have seen in some cases that duality is with a deterministic process. It would seem feasible that if the requirement is loosened so that the target is just a signed measure (rather than a positive probability measure), for example, more 'dualities' may be possible.

The applications explored here have been restricted to populations of particles from a single species. However, the use of additional operators for multi-species models is certainly possible [25], and would be a natural way to approach some of the more complex birth-death processes found in [14, 15], where mutation, selection and genealogies are additional features of interest. Investigating the extent to which Doi-Peliti techniques can produce the dualities found there would certainly be of interest.

The Doi methods described are applicable when the drift and noise terms are polynomial in nature. For example, the stochastic cable equation that was analysed contained a linear drift term. More detailed models [40] suggest a cubic model may be more precise. This will be amenable to the kind of analyses we have employed, although this will entail a perturbative path integral expansion that will contain internal nodes corresponding to the cubic terms, which will paint a more complicated picture than that seen in Fig. 1. Whether these methods can be adapted to more general non-polynomial forms is an open problem, the solution of which would certainly increase its

utility. In some cases non-polynomial systems can be analysed, but this currently relies on transforming the system to a polynomial form (see conclusions in [44], for example).

For most processes discussed, the operator $B(x)$ has taken constant, or local, somewhat uninteresting forms $B(x)(p) = b(x(p))$, where the function $B(x)$ at p only depends on the function x at p . The jump-diffusion process had a ‘jump’ operator $\mathcal{L} = \iint dp dq R_{pq}(\psi_q^\dagger \psi_p - \psi_p^\dagger \psi_q)$, where R_{pq} represented the rate a particle at position p hops to q . Under duality, this translated to the drift term $B(x)(p) = \int dq R_{pq}(x(q) - x(p))$ in the corresponding stochastic PDE, resulting in a function $B(x)(p)$ that depends upon the entire function x . A fuller exploration of the range of possible operators $B(x)$ that arise from Liouvillian particle operator counterparts would certainly be of interest. These questions also apply to possibilities that will arise by considering more than one species of particle, and spatial processes other than diffusion; the convection terms in age structured systems, for example, may offer alternative features of interest [11, 27]. In some cases (e.g Eq. 61) we have seen restriction on coefficients to ensure the number of particles in the systems is finite. However, there are well characterized techniques for countably infinite systems of particles [1, 39], and extending these methods for these cases would be useful.

The Doi functionality has enabled duality to be established on quite a wide scale. However, there are a host of other classes of duality functions. For example, the duality function $\mathbb{I}_{x \leq y}$ exists for a wide class of Feller processes, which is provable by other means [38]. Whether other field theoretic approaches can connect these is an open problem.

Dealing with infinite dimensional diffusion is fraught with technical difficulties, and conversely, path integrals are notorious for their need of greater rigour. However, the latter methods have been shown above to offer a useful tool to explore dualities between stochastic processes, which can always be investigated in parallel with more rigorous methods.

References

- [1] S. Albeverio, Y. G. Kondratiev, and M. Röckner. Analysis and geometry on configuration spaces. *Journal of functional analysis*, 154(2):444–500, 1998.
- [2] T. Assiotis et al. Random surface growth and karlin-mcgregor polynomials. *Electronic Journal of Probability*, 23, 2018.
- [3] V. Bogachev, G. D. Prato, and M. Röckner. Uniqueness for solutions of fokker–planck equations on infinite dimensional spaces. *Communications in Partial Differential Equations*, 36(6):925–939, 2011.
- [4] V. Bogachev and M. Röckner. Mehler formula and capacities for infinite-dimensional ornstein-uhlenbeck processes with general linear drift. *Osaka Journal of Mathematics*, 32(2):237–274, 1995.
- [5] V. I. Bogachev, G. Da Prato, and M. Röckner. Fokker–planck equations and maximal dissipativity for kolmogorov operators with time dependent singular drifts in hilbert spaces. *Journal of Functional Analysis*, 256(4):1269–1298, 2009.
- [6] N. Bogoliubov. Kinetic equations. *Journal of Physics USSR*, 10(3):265–274, 1946.
- [7] M. Born and H. S. Green. *A general kinetic theory of liquids*. CUP Archive, 1949.

- [8] A. N. Borodin and P. Salminen. *Handbook of Brownian motion-facts and formulae*. Birkhäuser, 2012.
- [9] M. A. Buice and J. D. Cowan. Field-theoretic approach to fluctuation effects in neural networks. *Physical Review E*, 75(5):051919, 2007.
- [10] G. Carinci, C. Giardinà, C. Giberti, and F. Redig. Dualities in population genetics: a fresh look with new dualities. *Stochastic Processes and their Applications*, 125(3):941–969, 2015.
- [11] T. Chou and C. D. Greenman. A hierarchical kinetic theory of birth, death and fission in age-structured interacting populations. *Journal of statistical physics*, 164(1):49–76, 2016.
- [12] R. Coleman. *Calculus on normed vector spaces*. Springer Science & Business Media, 2012.
- [13] G. Da Prato and J. Zabczyk. *Stochastic equations in infinite dimensions*. Cambridge university press, 2014.
- [14] D. Dawson, A. Greven, et al. Hierarchically interacting fleming-viot processes with selection and mutation: Multiple space time scale analysis and quasi-equilibria. *Electronic Journal of Probability*, 4, 1999.
- [15] D. A. Dawson, A. Greven, and A. Greven. *Spatial Fleming-Viot models with selection and mutation*. Springer, 2014.
- [16] H. Dette, J. A. Fill, J. Pitman, and W. J. Studden. Wall and siegmund duality relations for birth and death chains with reflecting barrier. *Journal of Theoretical Probability*, 10(2):349–374, 1997.
- [17] M. Doi. Second quantization representation for classical many-particle system. *Journal of Physics A: Mathematical and General*, 9(9):1465, 1976.
- [18] M. Doi. Stochastic theory of diffusion-controlled reaction. *Journal of Physics A: Mathematical and General*, 9(9):1479, 1976.
- [19] D. G. Duffy. *Green's functions with applications*. CRC Press, 2015.
- [20] F. Flandoli, G. Zanco, et al. An infinite-dimensional approach to path-dependent kolmogorov equations. *The Annals of Probability*, 44(4):2643–2693, 2016.
- [21] W. H. Fleming. Diffusion processes in population biology. *Advances in Applied Probability*, 7:100–105, 1975.
- [22] C. Franceschini, C. Giardina, and W. Groenevelt. Self-duality of markov processes and intertwining functions. *Mathematical Physics, Analysis and Geometry*, 21(4):29, 2018.
- [23] L. Gawarecki and V. Mandrekar. *Stochastic differential equations in infinite dimensions: with applications to stochastic partial differential equations*. Springer Science & Business Media, 2010.
- [24] C. Giardina, J. Kurchan, F. Redig, and K. Vafayi. Duality and hidden symmetries in interacting particle systems. *Journal of Statistical Physics*, 135(1):25–55, 2009.
- [25] C. D. Greenman. A path integral approach to age dependent branching processes. *Journal of Statistical Mechanics: Theory and Experiment*, 2017(3):033101, 2017.
- [26] C. D. Greenman. Doi–peliti path integral methods for stochastic systems with partial exclusion. *Physica A: Statistical Mechanics and its Applications*, 505:211–221, 2018.
- [27] C. D. Greenman and T. Chou. Kinetic theory of age-structured stochastic birth-death processes. *Physical Review E*, 93:012112, 2015.
- [28] M. Hairer. An introduction to stochastic pdes. *arXiv preprint arXiv:0907.4178*, 2009.
- [29] C. Itzykson and J.-B. Zuber. *Quantum field theory*. Courier Corporation, 2012.
- [30] S. Jansen, N. Kurt, et al. On the notion (s) of duality for markov processes. *Probability surveys*, 11:59–120, 2014.
- [31] P. D. Jarvis, J. Bashford, and J. Sumner. Path integral formulation and feynman rules for phylogenetic branching models. *Journal of Physics A: Mathematical and General*, 38(44):9621, 2005.
- [32] S. Karlin and J. McGregor. The classification of birth and death processes. *Transactions of the American Mathematical Society*, 86(2):366–400, 1957.
- [33] S. Karlin and J. L. McGregor. The differential equations of birth-and-death processes, and the stieltjes moment problem. *Transactions of the American Mathematical Society*, 85(2):489–546,

- 1957.
- [34] D. G. Kendall. On the Generalized “Birth-and-Death” Process. *Ann. Math. Statist.*, 19:1–15, 1948.
- [35] J. G. Kirkwood. The statistical mechanical theory of transport processes i. general theory. *The Journal of Chemical Physics*, 14(3):180–201, 1946.
- [36] J. G. Kirkwood. The statistical mechanical theory of transport processes ii. transport in gases. *The Journal of Chemical Physics*, 15(1):72–76, 1947.
- [37] A. Kolmogoroff. Über die analytischen methoden in der wahrscheinlichkeitsrechnung. *Mathematische Annalen*, 104(1):415–458, 1931.
- [38] T. M. Liggett. *Interacting particle systems*, volume 276. Springer Science & Business Media, 2012.
- [39] K. Matthes, J. Kerstan, and J. Mecke. *Infinitely divisible point processes*. Wiley, 1978.
- [40] H. McKean Jr. Nagumo’s equation. *Advances in mathematics*, 4(3):209–223, 1970.
- [41] M. Möhle et al. The concept of duality and applications to markov processes arising in neutral population genetics models. *Bernoulli*, 5(5):761–777, 1999.
- [42] J. Ohkubo. Duality in interacting particle systems and boson representation. *Journal of Statistical Physics*, 139(3):454–465, 2010.
- [43] J. Ohkubo. Algebraic probability, classical stochastic processes, and counting statistics. *Journal of the Physical Society of Japan*, 82(8):084001, 2013.
- [44] J. Ohkubo. Extended duality relations between birth–death processes and partial differential equations. *Journal of Physics A: Mathematical and Theoretical*, 46(37):375004, 2013.
- [45] J. Ohkubo. Duality-based calculations for transition probabilities in stochastic chemical reactions. *Physical Review E*, 95(2):023304, 2017.
- [46] J. Ohkubo and Y. Arai. Duality in stochastic processes from the viewpoint of basis expansions. *Journal of Statistical Mechanics: Theory and Experiment*, 2019(6):063202, 2019.
- [47] L. Peliti. Path integral approach to birth-death processes on a lattice. *Journal de Physique*, 46(9):1469–1483, 1985.
- [48] F. Redig and F. Sau. Stochastic duality and eigenfunctions. In *International workshop on Stochastic Dynamics out of Equilibrium*, pages 621–649. Springer, 2017.
- [49] C. M. Rohwer and K. K. Müller-Nedebock. Operator formalism for topology-conserving crossing dynamics in planar knot diagrams. *Journal of Statistical Physics*, 159(1):120–157, 2015.
- [50] M. Schulz and P. Reineker. Exact substitute processes for diffusion–reaction systems with local complete exclusion rules. *New Journal of Physics*, 7(1):31, 2005.
- [51] M. Schulz and S. Trimper. Parafermi statistics and p-state models. *Physics Letters A*, 216(6):235–239, 1996.
- [52] D. Siegmund. The equivalence of absorbing and reflecting barrier problems for stochastically monotone markov processes. *The Annals of Probability*, pages 914–924, 1976.
- [53] U. C. Täuber. *Critical dynamics: a field theory approach to equilibrium and non-equilibrium scaling behavior*. Cambridge University Press, 2014.
- [54] N. G. Van Kampen. *Stochastic processes in physics and chemistry*, volume 1. Elsevier, 1992.
- [55] J. J. Vastola. The chemical birth-death process with additive noise. *arXiv preprint arXiv:1910.09117*, 2019.
- [56] J. J. Vastola. Solving the chemical master equation for monomolecular reaction systems analytically: a doi-peliti path integral view. *arXiv preprint arXiv:1911.00978*, 2019.
- [57] J. Yvon. *La théorie statistique des fluides et l’équation d’état*, volume 203. Hermann & cie, 1935.