

Accepted Manuscript

Title: Towards Upright Pedalling to drive recovery in people who cannot walk in the first weeks after stroke: movement patterns and measurement

Author: Nicola J. Hancock Lee Shepstone Philip Rowe Phyo K. Myint Valerie M. Pomeroy

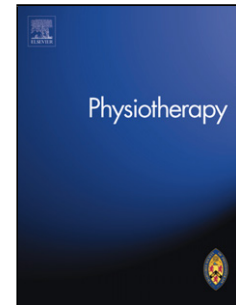

PII: S0031-9406(16)30482-5
DOI: <http://dx.doi.org/doi:10.1016/j.physio.2016.10.392>
Reference: PHYST 941

To appear in: *Physiotherapy*

Please cite this article as: Hancock Nicola J, Shepstone Lee, Rowe Philip, Myint Phyo K, Pomeroy Valerie M. Towards Upright Pedalling to drive recovery in people who cannot walk in the first weeks after stroke: movement patterns and measurement. *Physiotherapy* <http://dx.doi.org/10.1016/j.physio.2016.10.392>

This is a PDF file of an unedited manuscript that has been accepted for publication. As a service to our customers we are providing this early version of the manuscript. The manuscript will undergo copyediting, typesetting, and review of the resulting proof before it is published in its final form. Please note that during the production process errors may be discovered which could affect the content, and all legal disclaimers that apply to the journal pertain.

Title:

Towards Upright Pedalling to drive recovery in people who cannot walk in the first weeks after stroke: movement patterns and measurement.

Author Names and Affiliations:

Nicola J. Hancock ^a, Lee Shepstone ^b, Philip Rowe ^c, Phyo.K. Myint ^d, Valerie M. Pomeroy ^a

^a Acquired Brain Injury Rehabilitation Alliance, School of Health Sciences, University of East Anglia, Norwich Research Park, Norwich, NR4 7TJ, UK

^b Norwich Medical School, University of East Anglia, Norwich Research Park, NR4 7TJ, UK

^c Biomedical engineering Department, University of Strathclyde, Wolfson Centre, 106 Rotten Row, Glasgow G4 ONW, Scotland, UK

^d AGEING, Epidemiology Group, School of Medicine, Medical Sciences and Nutrition, University of Aberdeen, Aberdeen, Scotland, UK.

Corresponding Author:

Dr Nicola J Hancock

n.hancock@uea.ac.uk

Word Count: 3172

Ethical Approval: Essex 1 Research Ethics Committee ref. no. 09/H0301/52 (stroke survivor study) Norfolk Research Ethics Committee ref. no. 11/EE/0002 (healthy older adults study)

Funding: This work was part of a Medical Research Council (MRC) funded UEA PhD studentship awarded to the lead author Dr Hancock

Abstract:*Objectives*

To examine whether people who are within 31 days of stroke onset are able to produce controlled lower limb movement, and phasic activity in antagonistic lower limb muscle groups, during Upright Pedalling (UP).

Design

Observational study

Setting

Acute stroke unit within a University Hospital.

Participants

Eight adults between 3 and 30 days from stroke onset, with unilateral lower limb paresis and unable to walk without assistance. Participants were considered fit to participate as assessed by a physician-led medical team and were able to take part in UP for one, one minute session.

Intervention

Participants took part in one session of instrumented UP at their comfortable cadence, as part of a feasibility study investigating UP early after stroke.

Outcome Measures

Reciprocal activation of lower limb muscles derived from muscle activity recorded with surface EMG, quantified using Jaccards Coefficient (J); smoothness of pedalling determined from standard deviations of time spent in each of eight 45 degree wheel position bins ("S-Ped"). Motor behavioural measures: Motricity Index, Trunk Control Test, Functional Ambulatory Categories.

Results

Participants were all unable to walk (FAC 0) with severe to moderate lower limb paresis (Motricity Index score/100 median 48.5, IQR 32-65.5). Smooth pedalling was observed; some participants pedalling similarly smoothly to healthy older adults, with a variety of muscle activation patterns in the affected and unaffected legs.

Conclusion

These observational data indicate that people with substantial paresis early after stroke and who cannot walk, can produce smooth movement during UP using a variety of muscle activation strategies.

Contribution of paper:

- This paper contributes new knowledge on the lower limb movement patterns demonstrated by people who have considerable paresis early after stroke, during a functional activity in an upright posture.
- People unable to walk and within one month of stroke onset produced smooth movement of the lower limb using Upright Pedalling.

Key words:

Stroke, rehabilitation, lower limb, pedalling, walking, function

Introduction

Repetitive practice of goal-directed, skilled functional tasks, such as walking, enhances the brain changes that underly recovery of motor function after stroke [1,2]. However, people who are unable to walk due to substantial weakness cannot practice walking, and hence cannot benefit from practising the task. Indeed, these people are unlikely to have good recovery of walking function in response to the current package of rehabilitation interventions [3]. Identification and practice of better methods of walking rehabilitation are in the top-ten research priorities set by stroke survivors [4].

Body-weight support treadmill training (BWSTT) has been proposed as a tool to meet this challenge but provides no benefit over over-ground walking training [5]. Robotic systems and exoskeletons have recently emerged as possible interventions for walking practice after stroke but research findings are preliminary and, whilst it has been recently recommended that electromechanical gait training is considered for people who cannot walk independently after stroke [6], such devices are also expensive and potentially challenging to deploy in rehabilitation settings that include people's homes.

A potential way forward is to provide static reciprocal upright pedalling exercise [7]. Pedalling is a repetitive, functional activity with muscles organised into phasic groups [8]. Such muscle synergies have been demonstrated to be similar between walking and pedalling in a small sample of healthy adults during ergometer pedalling [9]. For stroke survivors the majority of published developmental studies employed recumbent seated pedalling equipment [e.g.10,11]. Whilst this equipment may be easier for stroke survivors to use, it does not provide the upright posture for lower

limb activity congruent with walking practice. Some support for upright pedalling (UP) is provided by the finding that participation in a modified vertical pedalling task produced an increase in quadriceps activity and increased net positive work output in response to verticality in people late after stroke [12]. UP could, therefore, provide task-specific training of walking-like movement in a more functional posture than sitting.

Objectives

The aim of this study was to assess the potential use of UP to train walking in those unable to actually walk early after stroke. As a first stage of investigation we examined whether stroke survivors who are within 31 days of stroke onset and unable to walk are able to produce:

- 1) controlled lower limb movement during UP, as measured by smoothness of pedalling activity; and
- 2) phasic activity in antagonistic lower limb muscle groups (quadriceps and hamstrings) during UP.

Methods

Design and ethics:

This observational study used data from eight participants for whom muscle activity and/or kinematic data were available from a feasibility study of 13 subjects in total investigating UP early after stroke [13]. These participants were those available to

attend a measurement session following the initial exploration of feasibility of using the equipment. In addition, included here are some control data from ten healthy older adults participating in UP in a later study carried out in our movement laboratory. Ethical approval and Research Governance approval were in place. All participants provided informed consent.

Participants:

All participants with stroke:

- Were adult in-patients of an acute stroke unit;
- Were between three and 30 days from stroke onset
- Had unilateral lower limb paresis
- Were unable to walk without assistance (scoring 0, 1 or 2 on the Functional Ambulatory Categories [14])
- Were considered fit to participate as assessed by a physician-led medical team with resting oxygen saturations of 95% or above, resting heart rate of 90 bpm or less and resting systolic blood pressure of 100-160mmHg
- Were able to follow a one-stage command
- Were able to participate in UP for at least one, one-minute session.

All healthy adult participants:

- Were adults of 50 years of age or over
- Were independent in community ambulation

UP equipment and instrumentation:

To provide (a) Upright Pedalling therapy for people with substantial lower limb paresis early after stroke and, (b) movement-based, physiological measurements to

characterise motor impairment, we designed a novel prototype Upright Pedalling device (U-Ped). U-Ped provides appropriate trunk and lower limb support for people with poor postural control and is instrumented to enable neural-biomechanical measurement of pedalling [13]. Postural support for the trunk and pelvis and variable seat height enables the upright posture required (Figure 1). Upright here refers to the participant's trunk being aligned with the seat tube and the angle between the seat tube and horizontal approximately 90 degrees [15].

The U-Ped wheel was divided into eight 45 degree position bins with reflective markers. During pedalling a LED sensor, placed at a fixed point on the bike frame, was triggered as each of the markers passed. This caused a spike in the software, recorded synchronously with surface electromyography (sEMG) data (*DataLink* system, Biometrics, UK). Thus muscle activity was mapped to the position of the pedal during the 360 degree turn. The crank angle was recorded between the right crank and the seat tube where 0 degrees represents top dead centre (TDC) and 180 degrees represents bottom dead centre (BDC) (Figure 2).

Procedure for participants with stroke:

Motor behaviour measures were taken:

- ability to produce voluntary muscle contraction in the lower limb as measured by the Motricity index [16],
- ability to walk as measured by the Functional Ambulatory Categories (FAC) [14], and
- trunk control as measured by the Trunk Control Test [17]

Participants were shown the U-Ped equipment in the testing area. They were then assisted into an upright position on the U-Ped and the trunk support and straps

adjusted as required for each individual. Following skin preparation, surface EMG electrodes (37mm x 18mm bipolar preamplifiers) were positioned over right and left quadriceps and hamstrings muscle groups: according to European recommendations (SENIAM 2013), the quadriceps sensor was attached to the centre of the anterior surface of the thigh, parallel to the muscle, and approximately half the distance between the iliac spine and superior patella, and the hamstrings sensor attached to the posterior thigh, approximately half the distance from the ischial tuberosity to the lateral epicondyle of the tibia. Electrodes were positioned with the subject sitting comfortably on U-Ped, not sitting on a table (quadriceps) nor lying prone (hamstrings) as recommended by SENIAM, as these positions was not reasonable for people so early after stroke. [18] A single researcher placed the electrodes for each participant.

Resting muscle data was then recorded at a frequency of 1000Hz with the foot supported on a box and the limb in 15 degrees of flexion for 30 seconds (see 'data processing' below). Participants were then asked to pedal for approximately one minute in order to familiarise themselves with the equipment. They were then asked to pedal again, and when they reached their self-selected comfortable cadence, data were recorded during a single pedalling trial of one minute. During pedalling, EMG data were recorded continuously at a sampling frequency of 1000Hz, using the *DataLink* system (Biometrics UK; high and low pass filters, 15 to 450Hz). The only resistance to pedalling was provided by the U-Ped crank itself, it was not considered appropriate to provide additional resistance as participants were early after stroke with substantial impairments. Hence, the load was the same for each participant.

Procedure for healthy older adult participants:

Participants were positioned comfortably on U-Ped, and pedalled for one minute at a comfortable cadence to familiarise themselves with the equipment. Data were then recorded exactly as for stroke survivor participants at rest and then at a cadence of 40rpm. This was selected as most closely matched the cadence of a group of later stage stroke survivors obtained in a further study of UP (unpublished findings, ABIRA group, UEA)

Data Processing:

Muscle activity data were processed using custom-written scripts in *Microsoft Excel 2007*. Raw signal was rectified and to reduce signal variability and present an accurate mean trend of signal development, data smoothing was carried out using a moving average of 50ms.

Establishing muscle activity bursts:

Baseline muscle activity was recorded from each muscle in supported upright sitting on the bike with the feet resting on blocks, knee resting at approximately 15 degrees of flexion. This procedure was designed so that any additional activity above this baseline would reflect that used to pedal the crank in the same upright posture.

Onset and offset of muscle activity was determined using a threshold of three standard deviations (3SD) above a participant's mean resting activity (e.g. [19, 20]). Baseline (threshold) EMG values were then calculated from the processed signal as the mean \pm 3 SD during the 30 seconds resting data collection period. Where activity was above this threshold value, the muscle was considered "on" and where below this threshold value, the muscle was considered "off".

Bursts of activity were mapped according to both the time of onset/offset and the crank angle. For each 45 degree position bin, onset of activity was described by the exact amount of time for which the activity was above the threshold, expressed as a percentage of total time for the relevant position bin. For example, if the muscle was continually above the threshold throughout a whole position bin, this would be 100% on, and if not above the threshold at all within a position bin, it would be 100% off, with any variations of percentage activity in between. This technique enabled a precise determination of muscle activity according to crank angle and removed the need to arbitrarily select a timeframe above which the muscle was considered active. It quantified the activity occurring during pedalling and could enable potential comparisons between pedalling sessions and individuals. It allowed for the production of phase diagrams to accurately depict activity (Figure 3) and is therefore a reproducible method for measuring muscle activity during UP.

Measurement of reciprocal activation and smoothness of pedalling:

Reciprocal activation of antagonistic muscle groups during UP:

Reciprocal activation was quantified using Jaccard's Coefficient (J) [21]:

$$J = \frac{a}{a + b + c}$$

where a= time muscles active together, b= time quadriceps active, hamstrings inactive and c= time hamstrings active, quadriceps inactive

A J-value of 1.0 therefore indicates complete co-contraction, or no reciprocal activation, of an antagonistic muscle pair. A J-value of 0 indicates no co-contraction

between the two muscles at all, and therefore complete reciprocal activation of antagonistic muscle groups.

Smoothness of pedalling movement (S-Ped):

Smoothness of pedalling movement (S-Ped) was determined from the standard deviation of the time spent in each of the eight position bins for each turn, over ten complete turns of the wheel taken from a central portion of each pedalling session (Figure 2). Hence, a lower standard deviation, and therefore a lower S-Ped score, indicates smoother pedalling than a higher standard deviation, represented by a higher S-Ped score

Analysis

Smoothness of pedalling, reciprocity of muscle activity and cadence were tabulated for individual participants and described alongside visual depictions of muscle activity using phase diagrams.

Results

Participant characteristics:

Table 1 presents characteristics for participants with stroke. In summary, participants were eleven days or less from stroke onset (Median= 8, IQR 6.75-9), unable to walk (FAC = 0, all participants), with severe to moderate lower limb paresis (MI score Median= 48.5, IQR 32-65.5), and all participants had impaired trunk control ability (TCT score Median= 43.5, IQR 37-74). Healthy adult participants (n=4 female) had a mean age of 58 years. Full data for the healthy adult participant group are not reported here as these are awaiting publication as part of a further study of UP.

Smoothness of lower limb movement:

Pedalling smoothness ranged from S-Ped 0.012 to S-Ped 0.164 with pedalling cadences ranging from 18.0rpm to 53.2rpm (Table 2). Whilst all participants demonstrated smooth pedalling activity, the lowest S-Ped scores were achieved by participants with the lowest comfortable pedalling cadences; conversely, smoothest pedalling activity was achieved by those with higher comfortable pedalling cadences. To aid interpretation of the derived scores, a median S-Ped of 0.014 at a cadence of 40rpm was established from the healthy older adults group.

Reciprocal activation of quadriceps and hamstrings:

Different muscle activation patterns, hence J-values, were found during UP in the current study, (Table 3), both in the affected and unaffected lower limb.

This heterogeneity is illustrated by a selection of phase diagrams created from the percentage activity throughout the pedalling cycle (Figure 3). Pattern variation included: reciprocal muscle activity in the affected leg (Figure 3a, $J=0.053$) accompanied by hamstring activity throughout much of the cycle in the less affected leg, with quadriceps contributing to the upstroke (Figure 3b, $J=0.245$); and, no activity in the affected leg (Figure 3c) with pedalling entirely by reciprocal muscle activity in the less affected leg (Figure 3d, $J=0.038$).

To aid interpretation of the derived scores, a mean J-value of 0.248 at a cadence of 40rpm was established from the healthy older adults group.

Discussion

Smooth pedalling was observed in this group of early stroke survivors, with a range of S-Ped scores from 0.012 to 0.164. Inter-participant differences in muscle activity patterns were found, in terms of phasic activity according to wheel position and reciprocity between muscle groups in both the affected and unaffected limbs. Results for smoothness and phasic muscle activity will now be considered in more detail.

Smoothness of lower limb movement during UP

The least controlled movement was observed at lowest pedalling speeds (S-Ped 0.164 at 18rpm; S-Ped 0.136 at 20rpm). Demands on stroke survivors pedalling early after onset are likely to be considerable as they attempt to re-establish coordinated movement patterns following damage to motor control systems. If able to achieve higher pedalling speeds, motor units are required that can rapidly activate and deactivate to meet the increasing frequency of the task [22] but at slower speeds it is possible that agonist/antagonist co-contraction, with its associated negative work, contributes to less smooth movement. When considering the potential of UP as a tool for rehabilitation of walking after stroke, it is very promising to note that three stroke survivors achieved smoothness scores slightly better than or close to that of the healthy older adults (0.012, 0.012 and 0.016 for stroke survivors compared to 0.014 for healthy older adults) and at similar cadences. That people very early after stroke might be able to produce a smooth, repetitive movement similar to that of people without stroke suggests UP might provide an opportunity for the targeted, behavioural activity required to drive beneficial changes after stroke. Whilst the coupled crank will inevitably have played a part in the findings here, not all stroke survivors were able to achieve such a result, indicating other factors such as

muscle control and function are likely to have made a contribution over and above the coupled system.

In the three participants for whom reciprocity was calculable for both legs, increased co-contraction was evident in the unaffected limb. It is possible here that the affected limb might be increasing negative work done throughout the cycle which in turn puts increased work on the unaffected limb of stroke survivors [23]. It is also noteworthy that the participant with the most reciprocal pedalling ($J=0.053$) in the affected leg also demonstrated a reciprocity score ($J=0.245$) in the unaffected leg closest to that achieved by healthy older adults ($J=0.248$). This again suggests potential for UP as a tool for provision of a “normal” movement experience after stroke, as lower limb activation in this way might assist development of sequential gait traits. However, further data are now required to explore a larger sample of participants and develop an understanding of what specific mechanisms UP might target.

Phasic muscle activity during UP

That we found inter-participant differences in muscle activity patterns during UP was unsurprising, as stroke does not have uniform effects on neural networks, and adaptive post-injury plasticity occurs in diverse regions both local to and remote from the primary site [24]. Indeed, inter-participant variability of muscle activity patterns during pedalling has been demonstrated in later-stage stroke survivors, using adapted ergometer pedalling in upright postures [23]. In contrast, these authors observed consistent patterns of activity in healthy older adults [23, 25]. Further work is needed to evaluate if patterning might continue or be disestablished with repeat UP sessions, and what the implication of that patterning might be to functional rehabilitation outcomes. For example, it might not be reasonable to assume

homogeneity of activity this early after the onset of stroke; stroke survivors might need to adopt a variety of strategies to achieve functional movement that can then be refined with on-going therapy support.

It is of note that smooth pedalling activity despite no measurable activity above baseline in either muscle group in the affected leg was observed in one participant (Figures 3c & 3d). This indicates pedalling by the unaffected limb alone and only passive movement of the affected limb due to the coupled crank, and highlights the importance of analysing activity in both limbs early after stroke. This use of the unaffected lower limb alone in pedalling activity early after stroke might not be deleterious- it has been suggested that up-regulation of ipsilateral excitatory pathways might assist the hemiplegic leg as the unaffected leg pedals [26]. The functional implication here is that even single limb pedalling, as seen in one participant in the current study, might make beneficial contributions to bilateral motor patterns post-stroke.

Limitations of the study

Excessive signal noise was experienced for two data recording sessions in the hospital setting, meaning that we were unable to calculate reciprocity scores in these cases. In order to enable synchronous recording of crank angle during UP we were limited to four channels on the subject unit available for EMG recording of muscle activity and were able to collect from two muscle groups only, right and left quadriceps and hamstrings.

The reported sample of stroke survivors was small (n=8), largely limited by rapid and unpredictable reconfiguration of local stroke services, though stringent selection

criteria ensured a well-defined participant group with homogeneity of some characteristics across participants.

Strengths of the study

The study recruited participants early after stroke, in the period in which the brain is most responsive to motor behavioural input. Meeting the challenge of recruiting people early after stroke is essential to the development of new rehabilitation interventions that can be initiated in the important first weeks after onset [27]. It was carried out in a University Hospital Stroke Unit, hence a “real world” setting for people early after stroke. For this developmental investigation, and to inform comparisons with future studies of the intervention, well-defined, replicable procedures for the use of sEMG during UP, were designed and reported here.

Exploratory work such as this is considered an important foundation for the development of complex rehabilitation interventions and their translation to clinical use [28].

Conclusion

This is, to the best of our knowledge, the first examination of elements of the neurophysiology of upright pedalling in people during the first few weeks after stroke. These observational data indicate that people with substantial paresis early after stroke and who cannot walk, even with the hands-on assistance of therapists, can produce smooth movement during UP using a variety of muscle activation strategies. This work has provided a platform for future iterative studies of UP. The next stage in this investigation is to begin to test the hypothesis that UP can drive walking recovery in people with substantial paresis early after stroke.

Conflict of Interest: The authors declare that they have no competing interests

References

- [1] Askim, T., Indredavik, B., Vangberg, T. & Haberg, A. Motor network changes associated with successful motor skill relearning after acute ischemic stroke: A longitudinal functional magnetic resonance imaging study. *Neurorehabilitation and Neural Repair* 2009; 23(3): 295-304
- [2] Perez, M.A., Lungholt, B.K.S., Nyborg, K. & Nielsen, J.B. Motor skill training induces changes in the excitability of the leg cortical area in healthy humans. *Experimental Brain Research* 2004; 159: 197-205
- [3] Kwakkel, G. & Kollen, B.J. Predicting activities after stroke: what is clinically relevant? *International Journal of Stroke* 2013; 8(1): 25-32
- [4] Pollock, A., St George, B., Fenton, M. & Firkins, L. Top ten research priorities relating to life after stroke. *The Lancet* 2012; 11; 209
- [5] Dobkin, B.H. & Duncan, P.W. Should body weight-supported treadmill training and robotic-assistive steppers for locomotor training trot back to the starting gate? *Neurorehabilitation and Neural Repair* 2012; 26: 308-317
- [6] Intercollegiate Stroke Working Party. *National Clinical Guideline for Stroke*, 5th Ed.2016; Royal College of Physicians, London. *Guidelines available at:* <https://www.strokeaudit.org/SupportFiles/Documents/Guidelines/2016-National-Clinical-Guideline-for-Stroke-5th-ed.aspx>
- [7] Hancock, N.J., Shepstone, L., Winterbotham, W. & Pomeroy, V. Effects of reciprocal pedalling exercise on motor function after stroke: A systematic review of randomized and non-randomized studies. *International Journal of Stroke* 2012; 7: 47-60
- [8] Raasch, C.C. & Zajac, F.E. Locomotor strategy for pedalling: Muscle groups and biomechanical functions. *Journal of Neurophysiology* 1999; 82: 515-525
- [9] Barroso, F.O., Torricelli, D., Moreno, J.C., Taylor, J., Gomez-Soriano, J., Bravo-Esteban, E., Piazza, S., Santos, C. & Pons, J.L. Shared muscle synergies in human walking and cycling. *Journal of Neurophysiology* 2014; 112(8): 1984-1988.
- [10] Katz-Leurer, M., Carmeli, E. & Shochina, M. The effect of early aerobic training on independence six months post stroke. *Clinical Rehabilitation* 2003; 17: 735-741
- [11] Katz-Leurer, M., Sender, I., Keren, O. & Dvir, Z. The influence of early cycling training on balance in stroke patients at the sub-acute stage: results of a preliminary trial. *Clinical Rehabilitation* 2006; 20: 398-405
- [12] Brown, D. A., Kautz, S.A., & Dairaghi, C.A. Muscle activity adapts to anti-gravity posture during pedalling in persons with post-stroke hemiplegia. *Brain* 1997; 120(5): 825-837.

- [13] Hancock, N.J., Shepstone, L., Rowe, P., Myint, P.K. & Pomeroy, V. Clinical efficacy and prognostic indicators for lower limb pedalling exercise early after stroke: An early phase randomised controlled trial. *Trials* 2011; 12: 68 <http://www.trialsjournal.com/content/12/1/68>
- [14] Holden, M.K., Gill, K.M., Magliozzi, M.R., Nathan, J. & Piehl-Baker, L. Clinical gait assessment in the neurologically impaired: reliability and meaningfulness. *Physical Therapy* 1984; 64: 35-40
- [15] Chen, H.-Y., Chen, S.-C., Chen, J.-J., Fu, L.-L., & Wang, Y.L. Kinesiological and Kinematical Analysis for Stroke Subjects with asymmetrical Cycling Movement Patterns. *Journal of Electromyography and Kinesiology* 2005; 15: 587-595.
- [16] Demeurisse, G., Demol, O. & Robaye, E. Motor evaluation in vascular hemiplegia. *European Neurology* 1980; 19: 382-389
- [17] Collin, C. & Wade, D. Assessing motor impairment after stroke: A pilot reliability study. *Journal of Neurology, Neurosurgery and Psychiatry* 1990; 53: 576-579
- [18] SENIAM: surface electromyography for the non-invasive assessment of muscles. 2013; guidelines available at <http://www.seniam.org>
- [19] Brown, D., Kautz, S.A. & Dairaghi, C.A. Muscle activity patterns altered during pedaling at different body orientations. *Journal of Biomechanics* 1996; 29(10): 1349-1356
- [20] Neptune, R.R., Kautz, S.A. & Hull, M.L. The effect of pedaling rate on coordination in cycling. *Journal of Biomechanics* 1997; 30(10): 1051-1058
- [21] Real, R. & Vargas, J.M. The probabilistic basis of Jaccard's Index of Similarity. *Systematic Biology* 1996; 45(3): 380-385
- [22] Ansley, L. & Cangle, P. Determinants of "optimal" cadence during cycling. *European Journal of Sports Science* 2009; 9(2): 61-85
- [23] Kautz, S. A. & Brown, D. A. Relationships between timing of muscle excitation and impaired motor performance during cyclical lower extremity movement in post-stroke hemiplegia. *Brain* 1998; 121: 515-526.
- [24] Nudo, R.J. Recovery after brain injury: mechanisms and principles *Frontiers in Human Neuroscience* 2013; 7: 1-14
- [25] Brown, D. A. & Kautz, S.A. Increased workload enhances force output during pedalling exercise in persons with post-stroke hemiplegia. *Stroke* 1998; 29: 598-606
- [26] Kautz, S. A., Patten, C. & Neptune R.R. Does Unilateral Pedaling Activate a Rhythmic Locomotor Pattern in the Nonpedaling leg in Post-Stroke Hemiparesis? *Journal Neurophysiology* 2006; 95: 3154-3163.
- [27] Stinear, C., Ackerley, S. & Byblow, W. Rehabilitation is initiated early after stroke- but most most motor rehabilitation trials are not. A systematic review. *Stroke* 2013; 44: 2039-2045
- [28] Craig, P., Dieppe, P., Macintyre, S., Mitchie, S., Nazareth, I. & Petticrew. M. Developing and evaluating complex interventions: the new Medical Research Council guidance. *BMJ* 2008; 337: a1655

Tables

Table 1: Participants with stroke: characteristics

Participant characteristics □	N=8 early stroke survivors; n=6 males; Median (IQR)	*all participants scored 0 on the Functional Ambulatory Categories
Age, years	76.5 (62.2-80.2)	
Time since stroke onset, days	8 (6.75-9)	
Motricity Index (/100)	48.5 (32-65.5)	
Trunk Control Test (/100)	43.5 (37-74)	

Table 2: Participants with stroke: individual smoothness scores and pedalling cadence

Participant ID	Smoothness Score (S-Ped) lower score=smoother pedalling	Cadence (rpm)
01	0.016	41.5
02	0.047	39.5
03	0.136	20.0
04	0.012	53.2
05	0.012	43.1
06	0.068	37.5
07	0.164	18.0
08	0.065	28.1

Table 3: Participants with stroke: Reciprocity scores, expressed as J-values

Participant ID	Reciprocity Score affected leg (J-value 0-1*)	Reciprocity Score unaffected leg (J-value 0-1*)
01	excessive signal noise	excessive signal noise
02	excessive signal noise	excessive signal noise
03	No quadriceps activity	0.005
04	No muscle activity	Quadriceps activity only
05	No muscle activity	0.038
06	0.288	0.531
07	0.468	0.608
08	0.053	0.245

* J-Value closer to 0= better reciprocal activity; J-value closer to 1= less reciprocal activity.

Figure Legends

Figure 1: U-Ped, demonstrating Upright Pedalling posture

Figure 2: Schematic representation of wheel bins and crank angle sensor system.
TDC= top dead centre, BDC= bottom dead centre

Figure 3: Illustrative phase diagrams from two participants with stroke demonstrating patterns of activity according to wheel position bin. Outer ring=hamstrings, inner ring=quadriceps. Grayscale used to indicate percentage activity, darker shading indicates more activity, lighter shading indicates less activity

Figures



sender

receiver

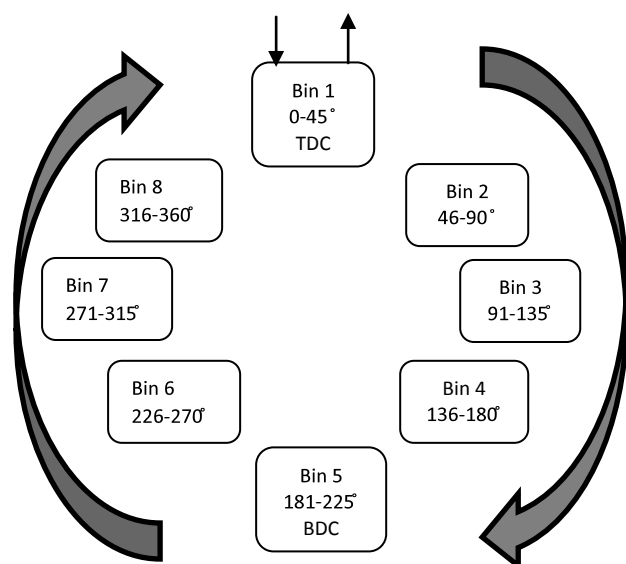
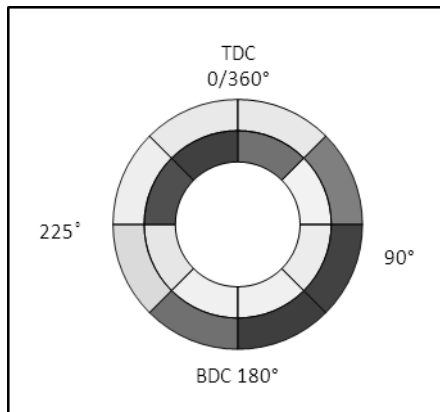
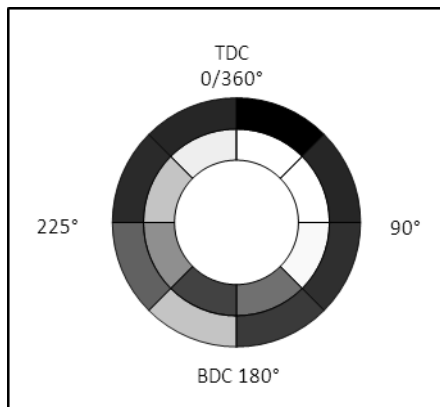

Figure 2

Figure 3



a. Participant 8; affected leg, demonstrating reciprocal muscle activity throughout cycle, $J=0.053$, accompanying moderately smooth pedalling ($S\text{-Ped}=0.065$)



b. Participant 8; unaffected leg, activity less reciprocal than in affected leg with hamstrings activity throughout the cycle and quadriceps contributing to the upstroke, $J=0.245$

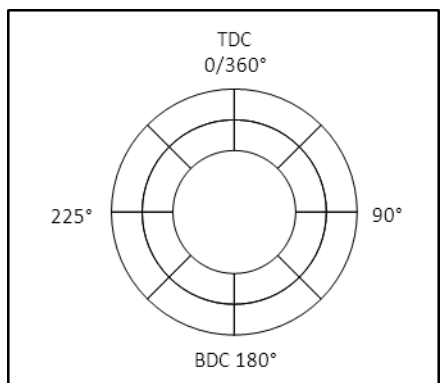

c. Participant 5; affected leg demonstrating no activity in quadriceps or hamstrings above resting, but smooth pedalling activity demonstrated ($S\text{-Ped} 0.012$) due to contribution from the unaffected leg (see d.)

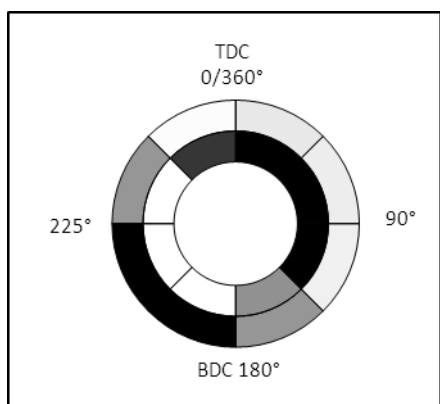

d. Participant 5; unaffected leg, demonstrating reciprocal muscle activity, $J= 0.038$, where the affected leg demonstrated no activity (see c.)