

α -Formylations with Chiral Chloroiminium Salts

Jamal Hassan
PhD Thesis
April 2013

Supervisor: Dr. C.J. Richards

This copy of the thesis has been supplied on condition that anyone who consults it is understood to recognise that its copyright rests with the author and that use of any information derived there from must be in accordance with current UK Copyright Law. In addition, any quotation or extract must include full attribution.

Acknowledgements

I would like to express my gratitude to my academic supervisor Dr. Chris Richards for his input and encouragement during my PhD research project. I would also like to thank my research group colleagues at the organic laboratory of the University of East Anglia, the INTERREG programme, and the EPSRC institution for the funding that it provided.

Abbreviations

Ac	acetyl
Ar	aryl
9-BBN	9-borabicyclo[3.3.1]nonane
BINAP	2,2'- <i>bis</i> (diphenylphosphino)-1,1'binaphthyl
Bn	benzyl
Bu ₂ BOTf	dibutylboron trifluoromethanesulfonate
Boc	<i>t</i> -butoxycarbonyl
Cbz	benzyloxycarbonyl
CBS	Corey-Bakshi-Shibata
Cy	Cyclohexyl
DAST	diethylaminosulfur trifluoride
DCE	dichloroethane
DCM	dichloromethane
DET	diethyl tartrate
DIBAL	diisobutyl aluminium hydride
DIPEA	diisopropylethylamine
DMF	<i>N,N</i> -dimethylformamide
DMS	dimethyl sulphide
DMSO	dimethyl sulfoxide
HMPA	hexamethylphosphoric acid triamide
HOMO	highest occupied molecular orbital
IPA	isopropyl alcohol
LDA	lithium diisopropylamide
MFA	<i>N</i> -methylformanilide
MMPT	magnesium monoperoxyphthalate
PMP	4-methoxybenzyl
Rose Bengal	2,4,5,7-tetraiodo-3,4,5,6-tetrachlorofluorescein
SAMP	(<i>S</i>)-1-amino-2-(methoxymethyl)pyrrolidine
RAMP	(<i>R</i>)-1-amino-2-(methoxymethyl)pyrrolidine
TBSOTf	<i>tert</i> -butyldimethylsilyl trifluoromethanesulfonate
Tf	trifluoromethanesulfonyl
TFA	trifluoroacetic acid
THF	tetrahydrofuran

Abstract

The synthesis of quaternary carbon centres is a challenging task in organic chemistry, and this is believed to be due to the significant amount of 'steric crowding' involved in the creation of a quaternary carbon centre. This thesis discusses the discovery and development of a new method for the preparation of α -formyl ketones containing an α -quaternary carbon centre. Ketone substrates were reacted with the Vilsmeier reagent (chloromethylene) dimethylammonium chloride (generated *in situ* from DMF and oxalyl chloride) followed by work up with aqueous base (NaHCO_3) to afford α -formyl ketones (8-88% yield). This methodology was extended to the asymmetric α -formylation of α -methyl indanone and α -methyl tetralone using chiral chloroiminium salts derived from (*S*)-proline. The asymmetric reactions gave enantiomeric excesses of up to 68%.

Publications

1. Title: α -Formylation of α -Substituted Ketones
Hassan, J., Richards, C.J. *Synlett* **2012**, 23, 239.
2. Title: Asymmetric α -Formylation of α -Methyl Indanone and α -Methyl Tetralone
(to be published).

CONTENTS

<u>Chapter 1</u>	<u>Page</u>
Literature review of asymmetric synthesis and Vilsmeier-Haack formylations	1-59
<u>Chapter 2</u> α-Formylation of α-substituted ketones	60
2.1 Introduction	62
2.2 Preparation of silyl enol ether 152	63
2.3 Formylation of silyl enol ethers 152, 154 and 158	64
2.4 Preparation of 2-methyl-1-indanone and 2-methyl-1-tetralone	70
2.5 Preparation of silyl enol ethers 167 and 168	72
2.6 α -Formylation of 2-methyl-1-indanone and 2-methyl-1-tetralone	74
2.7 Variation of the reaction parameters	76
2.8 Variation of the halo substituent and counter ion	78
2.9 Competitive α -formylation versus chloro-enal formation	80
2.10 Preparation of α -substituted ketones 174, 176 and 177	81
2.11 Modification of chromatography conditions in order to inhibit decarbonylation	85
2.12 Preparative α -formylation of various substrates	86
2.13 Proposed mechanism of α -formylation	94
2.14 Decarbonylation experiments	95
2.15 Reductive amination of α -formyl ketones 169 and 170	100
2.16 Summary	102
<u>Chapter 3</u> Asymmetric α-formylation with chiral chloroiminium salts	103
3.1 Introduction	104
3.2 Model of asymmetric of α -formylation using chiral formamides	109
3.3 Preparation of <i>N</i> -formyl-(<i>S</i>)-proline methyl ester 149	111
3.4 First attempt at synthesis of formamide 207	115
3.5 Preparation of product 216	121
3.6 Preparation of product 217	122
3.7 Preparation of product 218	124
3.8 Preparation of formamide 207	126
3.9 Preparation of formamide 208	127
3.10 Method used to measure stereoselectivity in α -formylation	131
3.11 Method for α -formylation and subsequent reductive amination	133
3.12 Attempt to determine absolute configuration of major diastereoisomer	140
3.13 Summary	142

<u>Chapter 4</u>	Experiments with other reaction types	143
4.1	Introduction	144
4.2	Preparation of enamine 226	145
4.3	Attempted kinetic resolution of 1-phenylethanol	147
4.4	Attempted kinetic resolution of 2-phenylpropanoic acid	149
4.5	Summary	151
4.6	Future work	152
	Conclusion	153
<u>Chapter 5</u>	Experimental Section	154
5.1	Experimental of Chapter 2	155
5.2	Experimental of Chapter 3	175
5.3	Experimental of Chapter 4	184
	<u>Appendices</u>	
	Appendix 1	187
	Appendix 2	188
	Appendix 3	189
	Appendix 4	190
	Appendix 5	191
	References	192

Chapter 1

1. Asymmetric Synthesis

1.1 Introduction

Asymmetric synthesis is an important area of organic chemistry with a lot of research being directed towards the development of methods for the stereoselective synthesis of chiral compounds.¹ The need for enantiomerically pure chiral compounds arises from the fact that chirality is a natural feature of biological processes.² In the past, medical drugs were administered as racemic mixtures until it became known that, in certain cases, one enantiomer of a drug was an effective treatment for a particular disorder whereas the other enantiomer was inactive or even harmful. One such example is the drug citalopram, used to treat depression:³

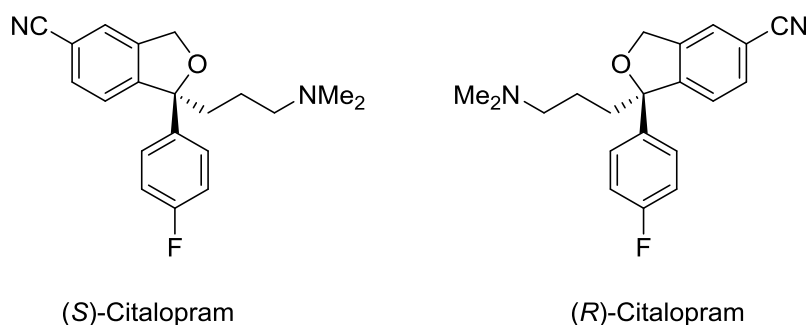

Figure 1

When administered to patients as a racemic mixture the drug is marketed as Celexa.³ Studies have shown that the *S* enantiomer is the active one, and that the *R* enantiomer is not only inactive, but that its presence inhibits the action of the *S* enantiomer.⁴ The drug's performance was improved by administering it to patients as enantiopure (*S*)-citalopram (escitalopram).^{3,4} Another example is the drug used to treat Parkinson's disease, L-dopa:

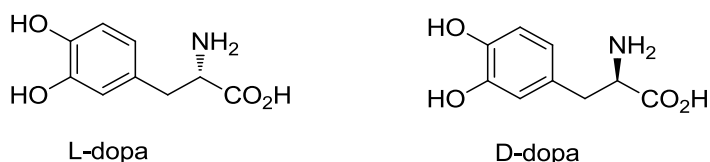

Figure 2

The L (or *S*) isomer is the active enantiomer whereas the D (or *R*) enantiomer is toxic.⁵ Since the 1980s legislation has been introduced requiring that drugs are prepared with minimum amounts of enantio-purity, where an inactive enantiomer is known to be harmful.¹ This has been a factor in the recent growth of chiral technology designed to produce highly enantiopure compounds.⁶

1.2 Chiral resolution

Racemic compounds can be resolved using chiral resolution methodology. For example, only the (*S*) enantiomer of naproxen **1**, an anti-inflammatory drug, is found to be active.⁷ The American pharmaceutical company Syntex used the following technique to separate a racemic mixture of the compound, and thereby obtain the active enantiomer with the necessary enantiopurity.^{8,9} Racemic naproxen **2**, a carboxylic acid, was reacted with a single enantiomer of a chiral glucose derivative, *N*-propylglucosamine **3**, to form the corresponding ammonium carboxylate salts **4**, **5** (Scheme 1).⁹

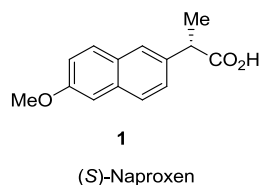
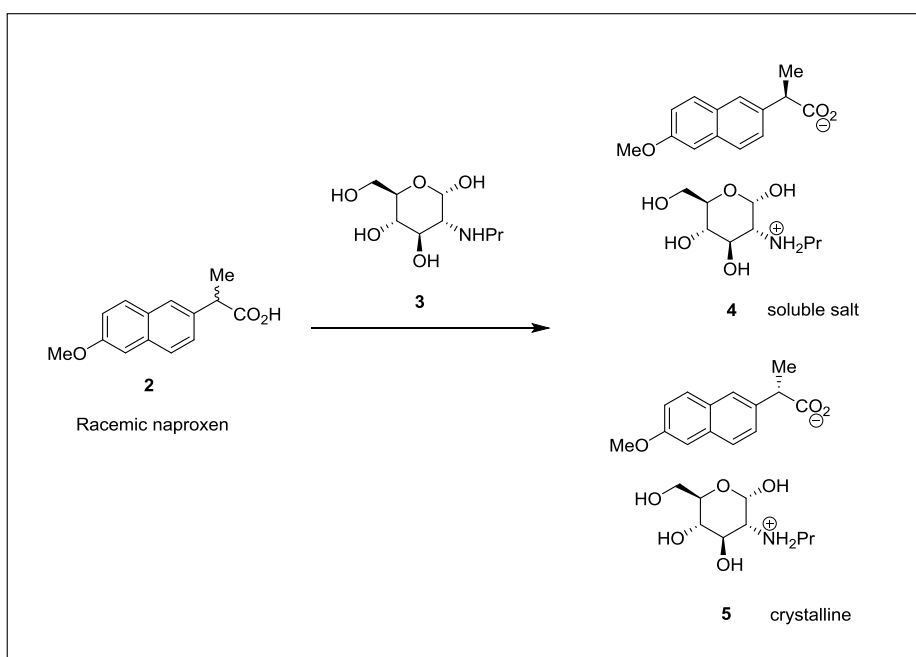
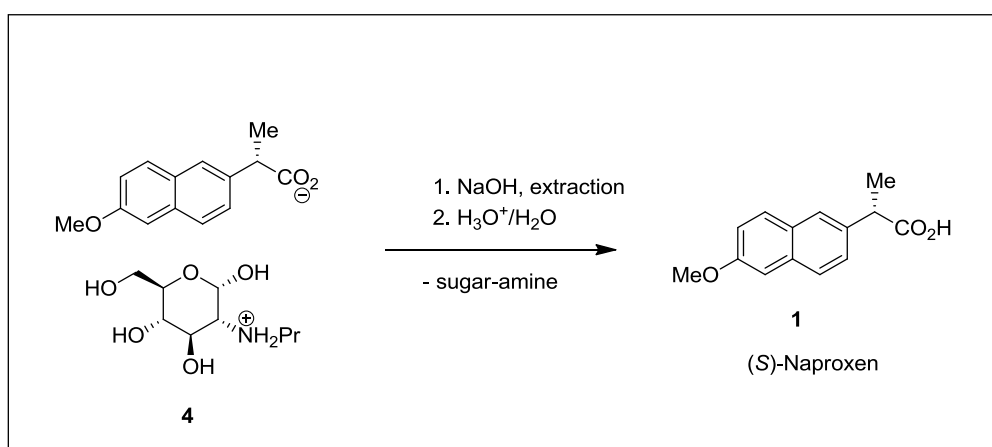

Figure 3



Scheme 1 Resolution of racemic naproxen.⁹

The diastereomeric salts thus formed have different solubility properties, the salt of the amine with (*R*) naproxen being soluble while the salt of the amine with (*S*) naproxen is insoluble. The insoluble (*S*) salt crystallizes out of solution and can therefore be filtered and then basified, with sodium hydroxide, to deprotonate the ammonium group and thereby release the sugar amine. The amine is then removed by extraction into an organic solvent leaving the sodium carboxylate in the aqueous layer. Finally the sodium carboxylate is acidified, to reprotonate the carboxylate anion, extracted into an organic solvent, and isolated as the single (*S*) enantiomer (Scheme 2).⁹



Scheme 2 Resolution of racemic naproxen.⁹

1.3 Chiral pool strategy

The preparation of enantiopure compounds by resolution of racemic mixtures has a drawback which is that half of the material produced, the unwanted enantiomer, is discarded, making the process wasteful and expensive, especially if several steps are involved in the synthesis. Another limitation is that the compound to be resolved must contain an acidic or basic functional group that can react to form a diastereomeric salt. This led chemists to seek new and more efficient ways of preparing enantiopure compounds.¹⁰ One such method is called the ‘chiral pool strategy’ which makes use of the fact that enantiopure chiral compounds are abundant in nature. In this technique, readily available single enantiomers of chiral compounds, derived from nature, are used as precursors in the synthesis of an enantiopure target molecule. A compound is chosen which has the required stereochemistry at one or more stereogenic centres. It is then transformed into the target material by one or more synthetic steps, which

may or may not introduce any additionally required stereochemistry, without affecting the chiral integrity of the starting precursor.¹⁰

Stork and co-workers have reported the synthesis of Prostaglandin A₂ from hemiacetal **6** derived from the chiral pool sugar L-rhamnose.^{11,12} The hemiacetal **6** was reacted with vinyl magnesium chloride to give the vinyl carbinol **7** which, after protection of the primary alcohol as a methyl carbonate, was made to undergo an orthoester Claisen rearrangement to give the acetonide **8**. Hydrolysis of the acetonide, and subsequent recyclization gave the carbonate **9**, which was reacted with the trimethylorthoester of 8-carbomethoxy-4-octanoic acid in a second Claisen rearrangement, on the allylic alcohol, followed by hydrolysis of the cyclic carbonate functionality, to give compound **10** (Scheme 3).

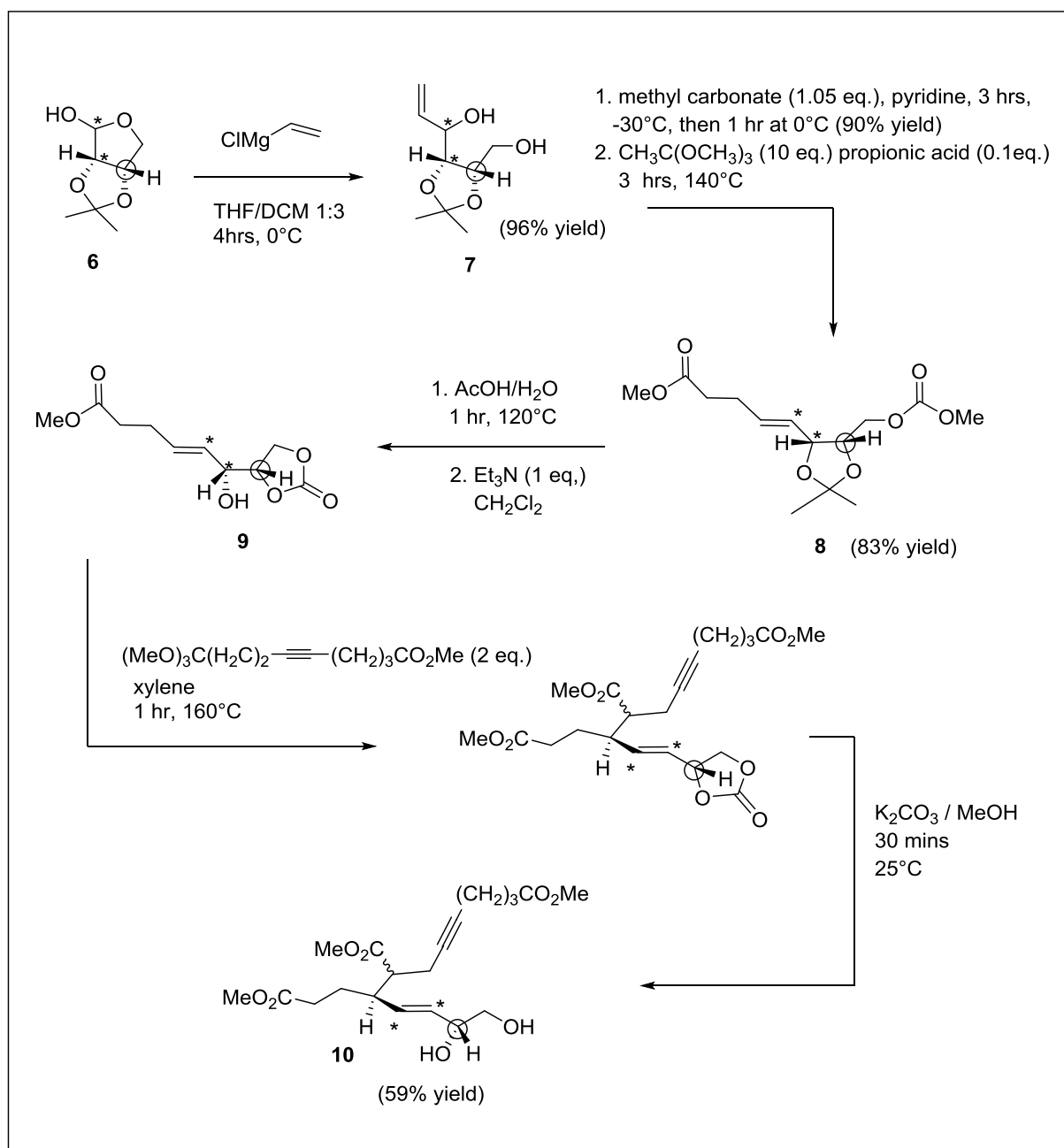

Scheme 3 Chiral pool synthesis of Prostaglandin A₂.¹¹

The new chiral centre adjacent to the ester group in compound **10** was formed as a mixture. Semi-hydrogenation of the carbon-carbon triple bond, protection of the secondary alcohol (with ethyl vinyl ether), and conversion of the primary alcohol to a butyl group (*via* a tosylate) gave compound **11** (Scheme 4). Finally, ring closure and the introduction of the carbon-carbon double bond on the five membered ring gave Prostaglandin A₂ **12** (Scheme 4).¹² The fact that compound **10** was formed as a racemic mixture was immaterial because the final steps in the

synthesis *i.e.* ring closure and formation of the carbon-carbon double bond, occurred under equilibrium conditions to afford the desired Prostaglandin A₂ **12** as the thermodynamic product.^{11,12}

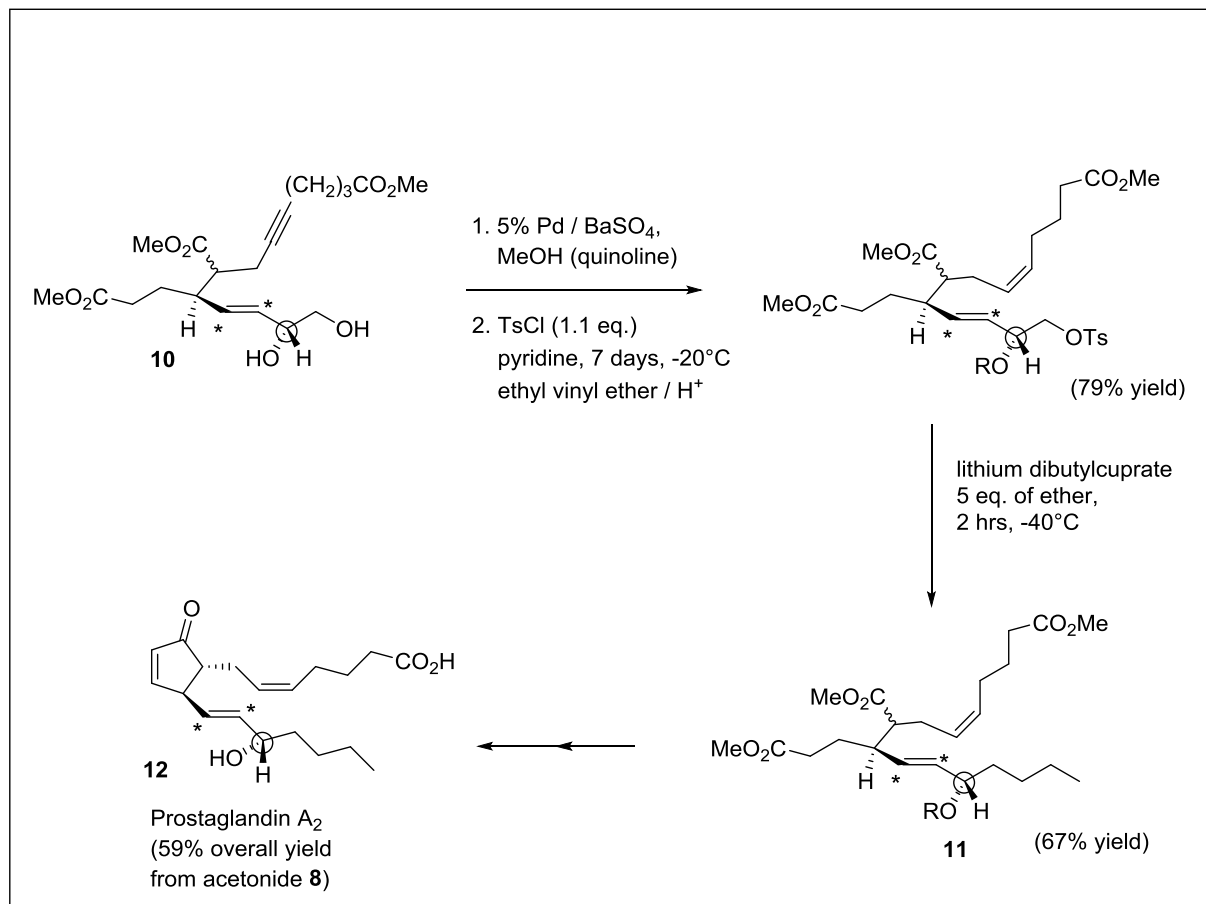

Scheme 4 Chiral pool synthesis of Prostaglandin A₂.¹¹

Another example of a chiral pool synthesis is the preparation of enantiomerically pure 4-pyridones from D-mandelic acid **13** by a condensation reaction between the substrate and various enamino ketones **14** to give β -ketoenamides **15**, with subsequent cyclocondensation to afford the 4-pyridone **16** (Scheme 5).¹³

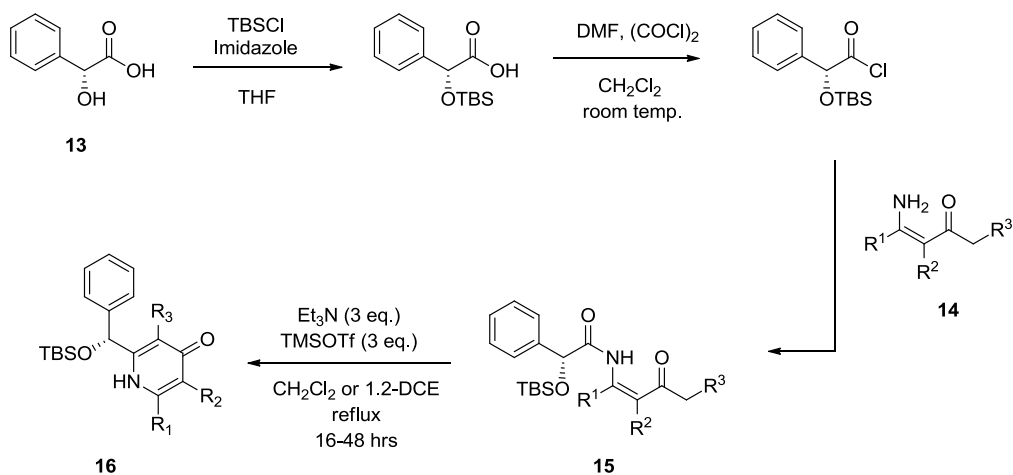

Scheme 5 Preparation of 4-pyridones from D-mandelic acid *via* β -ketoenamides.¹³

Table 1 Preparation of 4-pyridones from D-mandelic acid *via* β -ketoenamides.¹³

entry	enamino ketone	β -ketoenamide	yield ^(a)	4-pyridone	yield ^(b)
1			84 (66) ^(c)		91
2			13		40 ^(d)

(a), (b) Yield of purified products. (c) 10g scale (d) reaction time was 7 days, the product was isolated as the unprotected (hydroxymethyl)-4-pyridone.

However the chiral pool approach also has a limitation, in that a precursor which resembles the target molecule fairly closely must be available. If not, many synthetic steps may be necessary, making the approach unviable.¹⁰

1.4 Chiral auxiliaries

An alternative method of synthesising enantiopure compounds involves the use of chiral auxiliaries. In this technique an enantiopure chiral reagent, called a chiral auxiliary, is reacted with a substrate to form an enantiomeric intermediate, which reacts diastereoselectively with a second compound to form, after removal of the auxiliary, an enantiomerically pure product.¹⁰ In mechanistic terms, the presence of the chiral auxiliary gives rise to two diastereomeric transition states, where one is significantly higher than the other. Ideally a chiral auxiliary should be easy to attach to the substrate, it should favour diastereoselective addition in the new bond forming step, and finally it should be removed (and ideally recoverable) under mild conditions, which do not threaten the chiral integrity of the product.^{14,15}

The Evans chiral auxiliary, an oxazolodinone **17**, has found many applications in stereoselective carbon-carbon bond forming reactions including alkylations, aldol reactions and Diels-Alder additions.¹⁵ The aldol and alkylation reactions involve the selective enolization of an *N*-acyl oxazolodinone, using base (usually lithium diisopropyl amide), followed by subsequent alkylation or aldol reaction of the enolate, to give the corresponding products **18** and **19** respectively, with a high level of stereoselectivity (Scheme 6).¹⁵

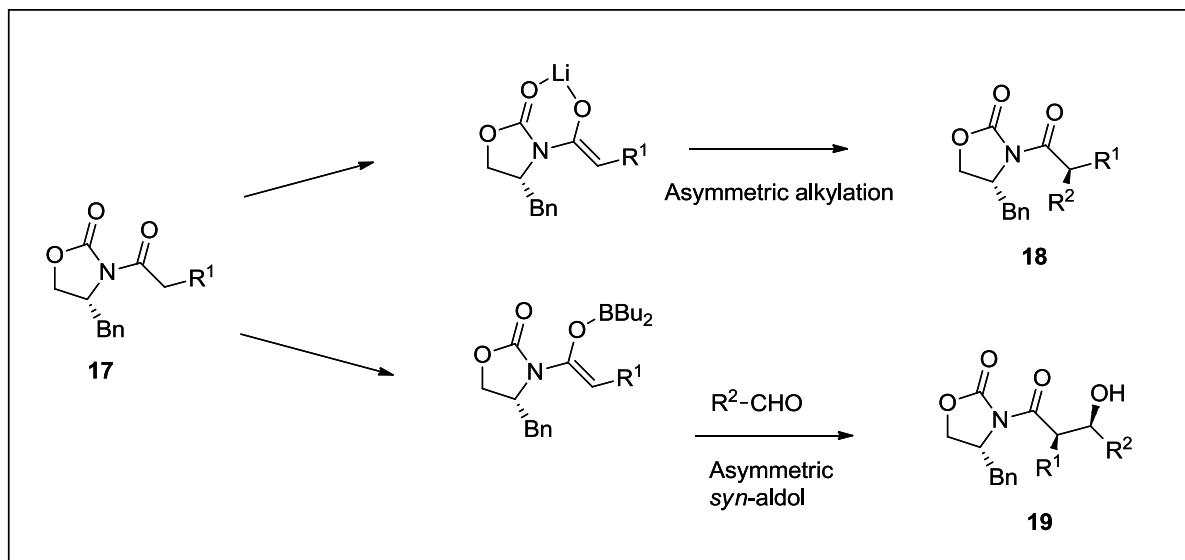

Scheme 6 Asymmetric Alkylation and Aldol reactions using Evans oxazolodinone.¹⁵

In the boron mediated Evans aldol reaction, an Evans auxiliary is reacted with a substrate to form an *N*-acyl oxazolodinone **20** which is deprotonated by *N,N*-diisopropylethylamine (DIPEA) in the presence of Bu_2BOTf to give a boron enolate **21**.¹⁶ The enolate is then reacted with an aldehyde, at low temperature, with attack by the electrophile occurring at the less hindered face to give an aldol product **23** (Scheme 7).^{16,17}

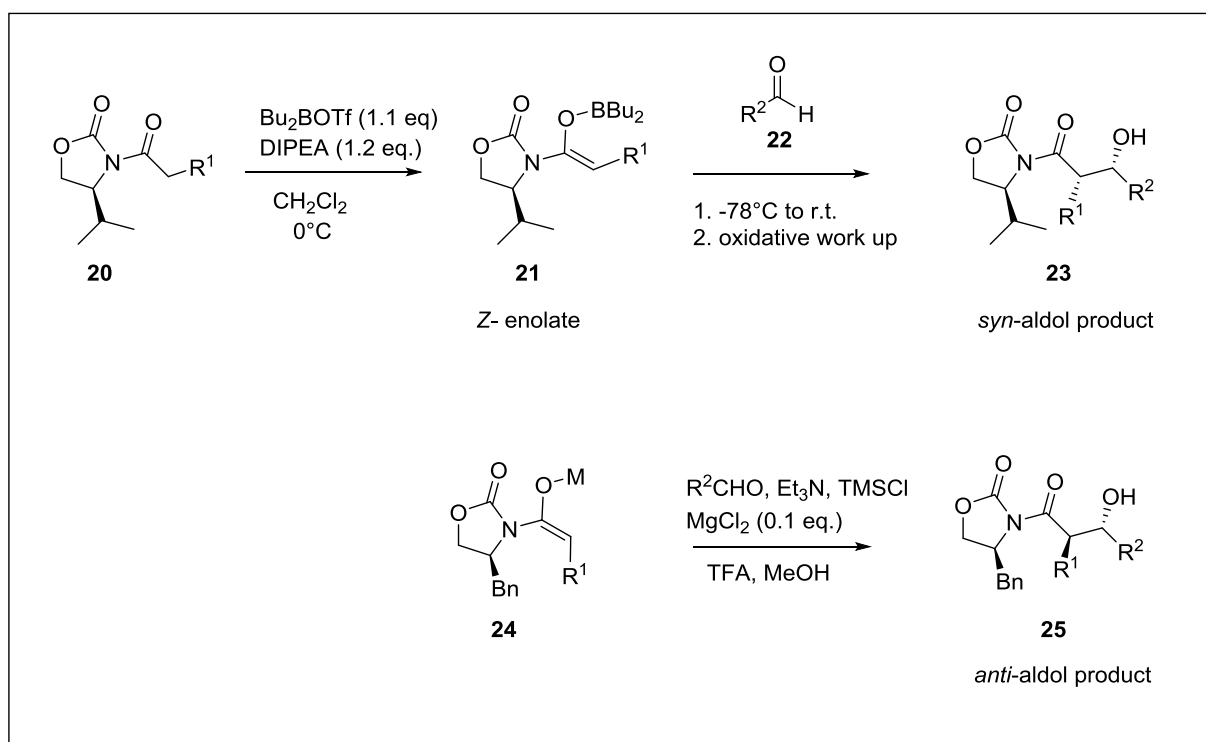

Scheme 7 Boron mediated Aldol reaction using Evans oxazolodinone.¹⁶

A highly selective enolisation process occurs to give the *Z*-boron enolate **21**, followed by a face selective bond forming step to give the *syn*-aldol product. This is because the transition state leading to the *syn* product is favoured (for the *Z*-boron enolate) whereas that leading to the *anti* aldol product is disfavoured.¹⁶ The face selectivity of this step arises from the fact that the bulky isopropyl group hinders attack at one face, so that attack occurs preferentially at the other face. The selective formation of the *Z*-boron enolate **21** is important because reaction of the corresponding *E*-boron enolate with the electrophile would give the *anti*-aldol product.¹⁶ It is the reaction conditions employed that control the enolisation process and lead to the formation of the *Z*-enolate, and *E*-boron-enolates can also be formed under certain reaction conditions.^{17,18} The Evans oxazolodinone can also be used to obtain *anti*-aldol products (Scheme 7).¹⁵ Evans and co-workers used chiral oxazolodinone **26** to obtain a *syn*-aldol

product in one of the steps leading to the total synthesis of cytotoxic natural product (-)-FR182877 **27** (Scheme 8).^{16,19}

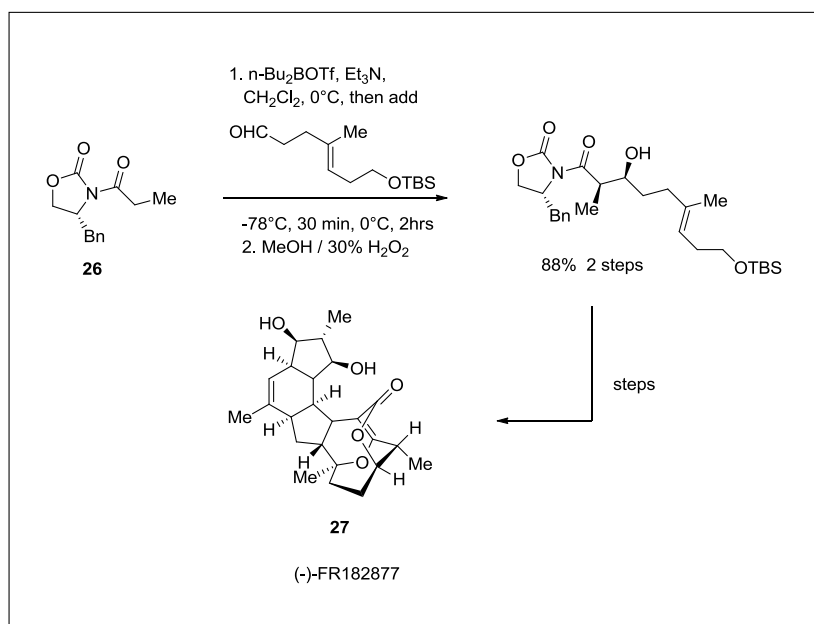

Scheme 8 Synthesis of natural product (-)-FR182877.¹⁶

Enders hydrazones are used for the α -alkylation of ketones using the chiral auxiliary (*S*)-1-amino-2-methoxymethylpyrrolidine (SAMP) **28** derived from the naturally occurring amino acid (*S*)-proline.²⁰ The ketone is heated with the hydrazine, in the presence of a catalytic quantity of acid, to give intermediate **29** which is deprotonated by lithium diisopropylamide at low temperature to give an azaenolate, followed by α -alkylation with an alkyl halide to give intermediate **30**. Ozonolysis of this intermediate, or reaction with methyl iodide followed by hydrolysis with aqueous acid, affords the α -alkylated ketone product (Scheme 9).^{21,22}

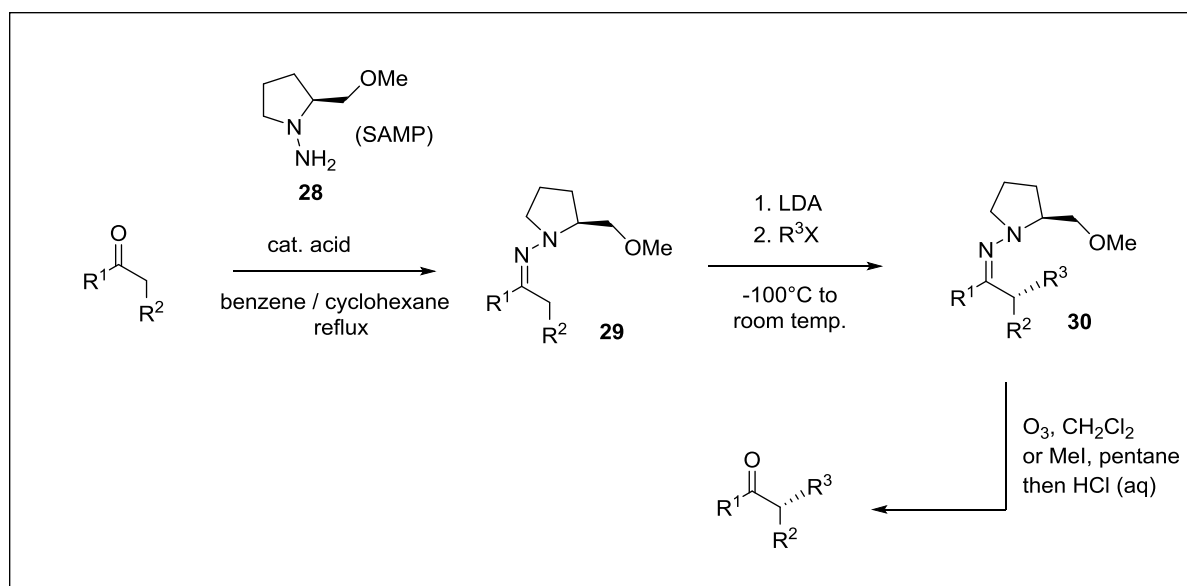

Scheme 9 Asymmetric alkylation using SAMP hydrazone.²²

In the first step of the reaction, the chiral auxiliary reacts with the substrate to give hydrazone **29**, which is deprotonated at the α position to give a monomeric azaenolate which has *E* geometry around the C=C double bond, and *Z* geometry around the C-N bond.^{20,21} In this azaenolate the lithium atom is intramolecularly chelated by the methoxy group which is located below the plane of the CCNN bonds (in the SAMP derived system). The alkyl halide then attacks this azaenolate at the sterically more accessible face to give intermediate **30**, and this accounts for the high diastereoface selectivity (Scheme 10).^{20,21} The opposite enantiomer of the product can be obtained by using (*R*)-1-amino-2-methoxymethylpyrrolidine (RAMP) as the chiral auxiliary, and the general reaction is referred to as an Enders SAMP/RAMP hydrazone alkylation.²²

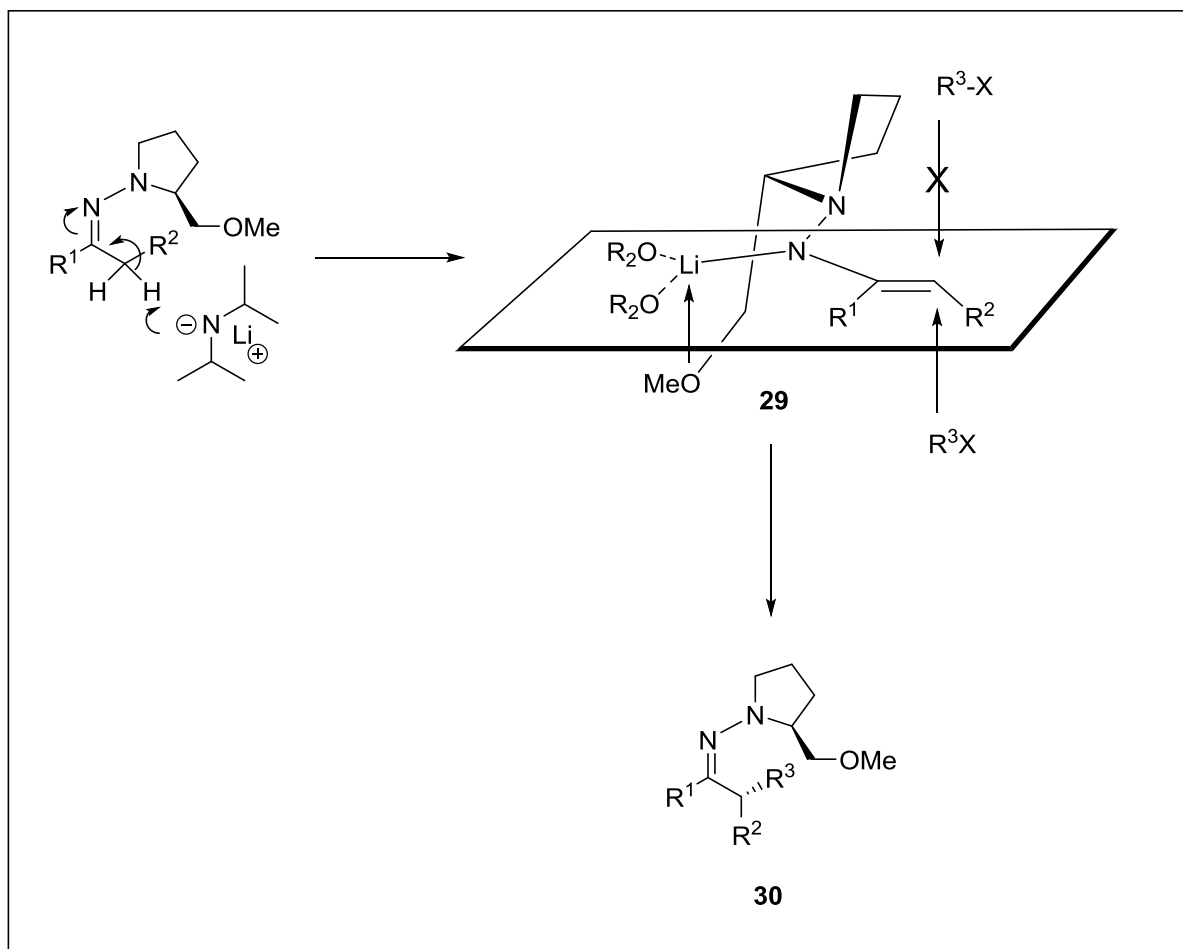

Scheme 10 Mechanism of the SAMP hydrazone alkylation.²¹

This transformation was used by Toro and co-workers in the first total synthesis of the diterpenoid natural product (+)-maritamol **32**. A SAMP hydrazone alkylation was used to introduce the stereocentre at the C12 position to give compound **31** (Scheme 11).^{21,23}

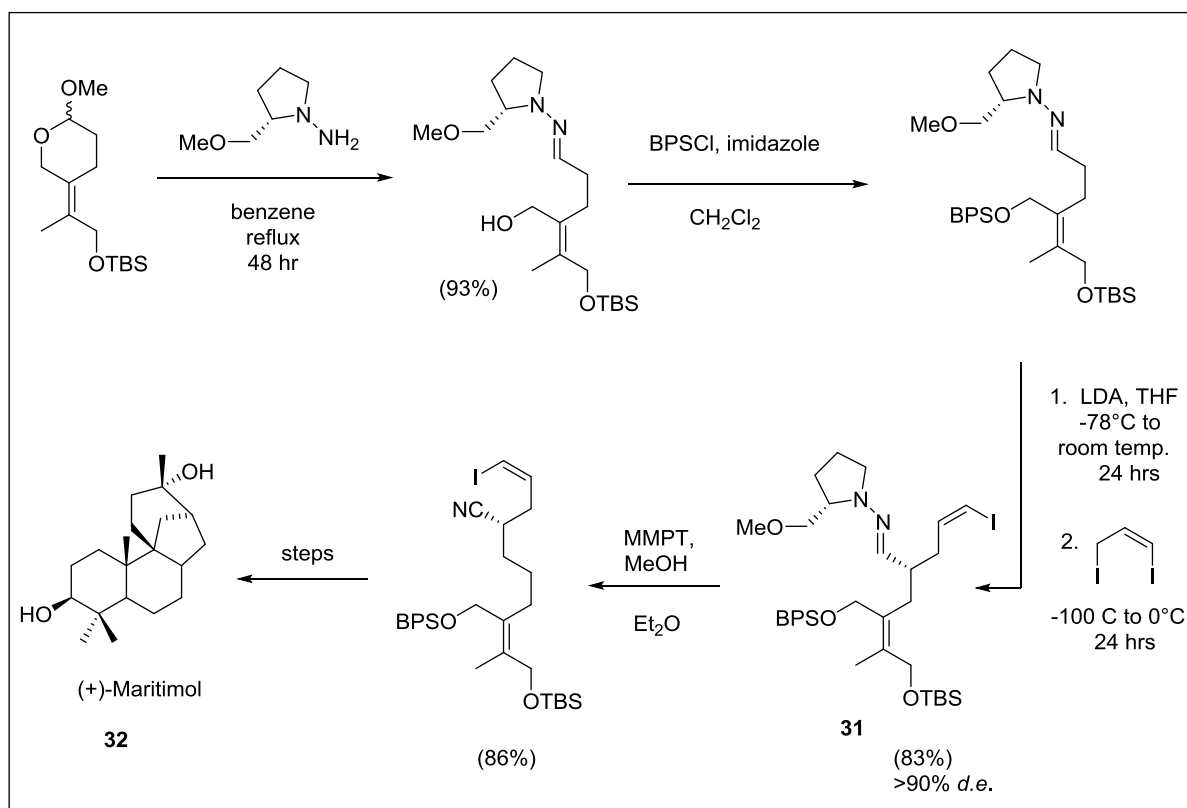

Scheme 11 Total synthesis of the diterpenoid natural product (+)-Maritamol.^{21,23}

1.5 Chiral reagents

In the chiral auxiliary strategy, a prochiral substrate is made into a chiral intermediate by reaction with an enantiomerically pure chiral compound. A different approach is to use a stoichiometric chiral reagent, which reacts with a prochiral substrate to give a desired product enantioselectively.¹⁰ In the Midland Alpine Borane reduction, an aldehyde or ketone is reduced to a primary or secondary alcohol, using a boron chiral reagent. The reaction was first discovered by M.M. Midland and co-workers in the late 1970s, who found that B-alkyl-9-borabicyclo[3.3.1]nonane reduced benzaldehyde to benzyl alcohol.²⁴ They then developed an asymmetric version of the reaction by using B-3 α -pinanyl-9-BBN **35** as a stoichiometric chiral reagent. The reagent is prepared from (+)- α -pinene **33** by reaction with 9-BBN **34** at reflux in tetrahydrofuran (Scheme 12).²⁵ The mechanism of the reaction involves the formation of a cyclic boatlike transition state where the carbonyl compound is oriented so that the larger of its two substituents is in the equatorial position and the smaller is in the axial position, and this

determines the absolute configuration of the product alcohol.²⁵ In the synthesis of the natural product (+)-chondrillin **36** by Dussalt and co-workers, the Midland reduction was used to make the first stereogenic centre (Scheme 12).^{25,26}

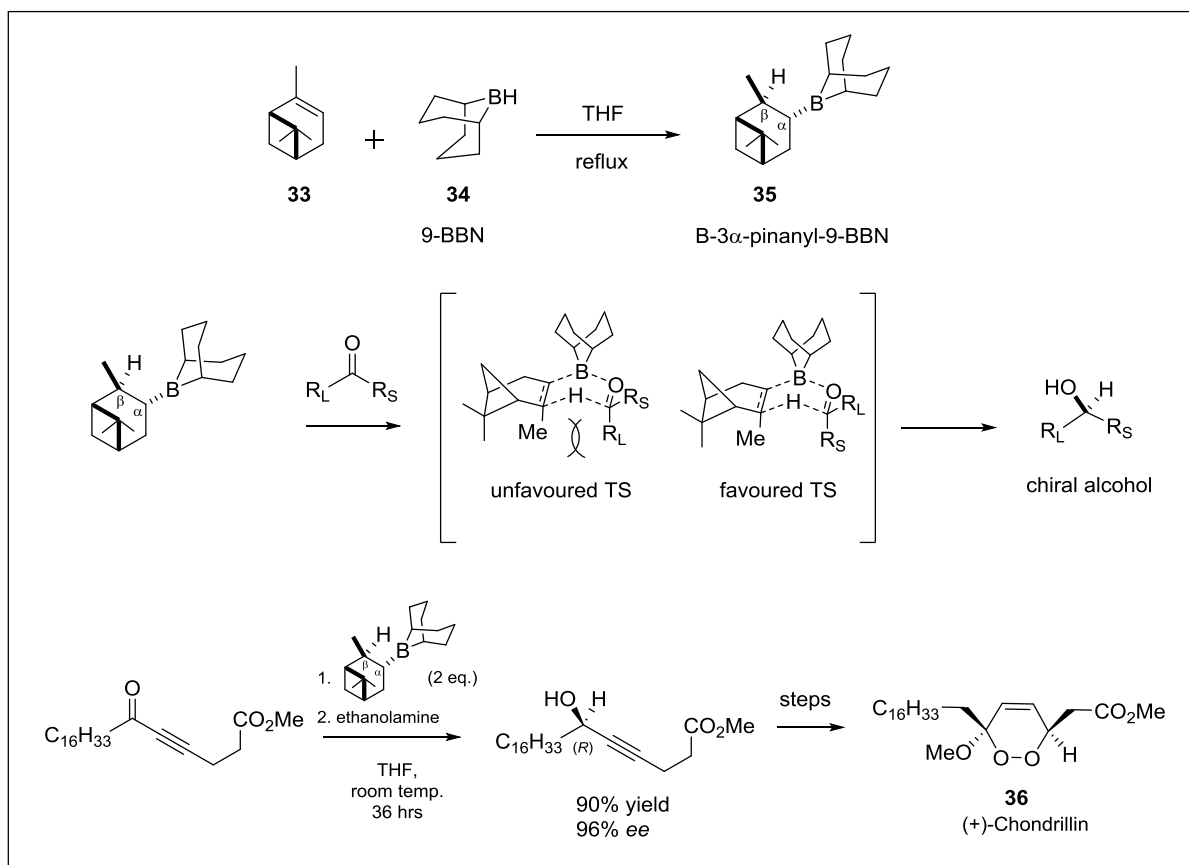

Scheme 12 Synthesis of the natural product (+)-Chondrillin using a Midland reduction.²⁵

1.6 Chiral catalysts

In the Corey-Bakshi-Shibata (CBS) reduction, a prochiral ketone is reduced to a secondary alcohol by reaction with a stoichiometric quantity of borane in the presence of a catalytic quantity of oxazaborolidine **37** derived from (*S*)-proline.^{27,28} Borane, a Lewis acid, coordinates to the nitrogen of the oxazaborolidine, in what is reported to be a reversible step, to form a CBS-borane complex.²⁹ This coordination is rapid and occurs on the α -face of the oxazaborolidine to form the *cis*-fused oxazaborolidine-borane complex **38** (Scheme 13).³⁰ The

coordination of the electrophilic BH_3 activates it as a hydride donor and also increases the Lewis acidity of the endocyclic boron atom. This Lewis acidic endocyclic boron then binds a molecule of the ketone substrate at the more sterically accessible oxygen lone pair, with the larger of the ketone's two substituents held in a pseudoequatorial position (intermediate **39**). In this way unfavourable interactions between the ketone and the complex are minimised, and the carbonyl group of the ketone is aligned with the coordinated BH_3 , so that face selective hydride transfer from the borane to the ketone occurs, *via* a cyclic six membered transition state to form intermediate **40**, and this accounts for the facial selectivity (Scheme 13).^{29,30}

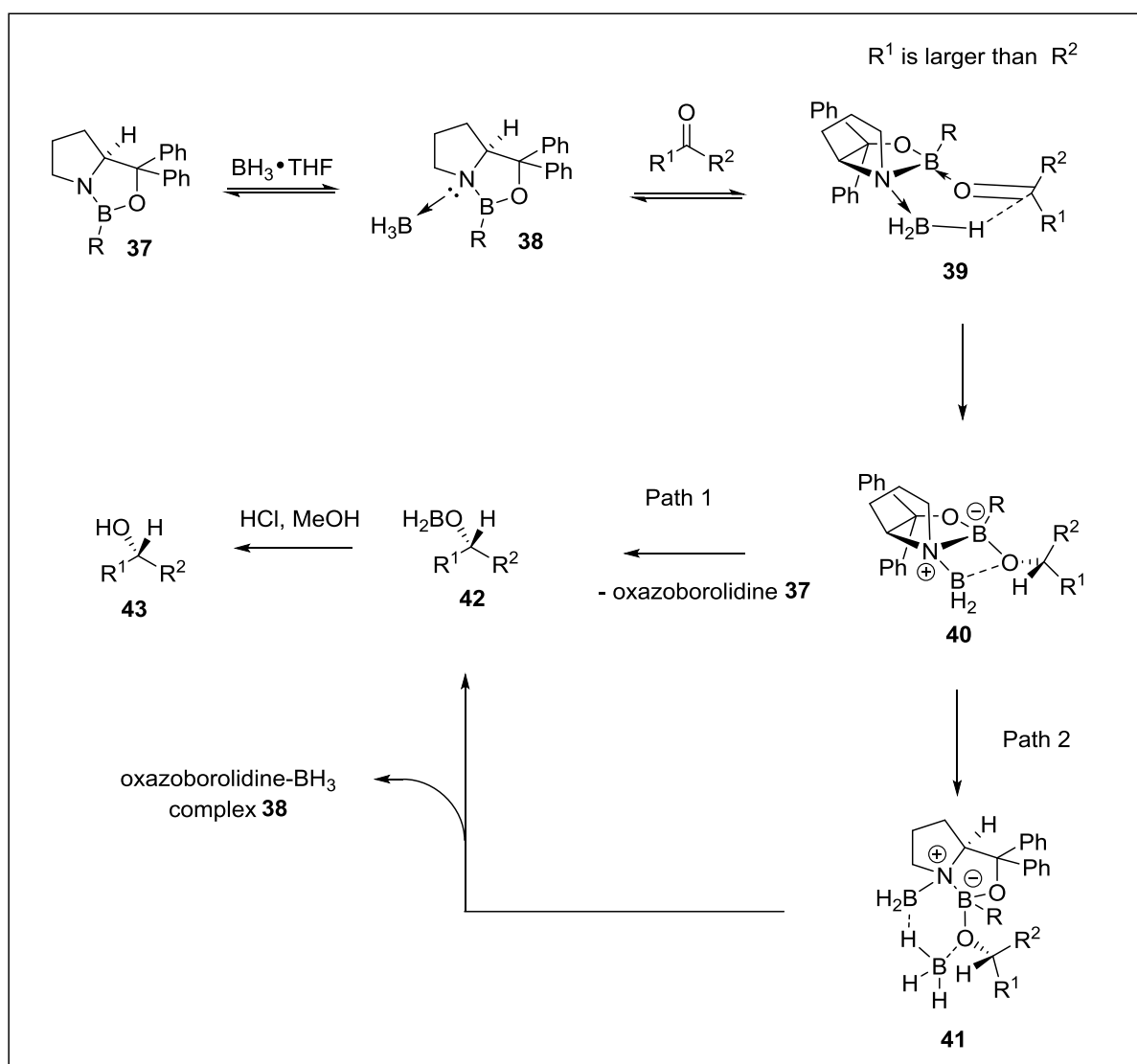

Scheme 13 Mechanism of the CBS reduction.^{29,30}

Coordination of the ketone and hydride transfer are both fast processes and are believed to be comparably rate limiting. Dissociation of the reduction product from intermediate **40** to regenerate the catalyst can occur by two different pathways.²⁹ In path 1, the newly formed alkoxide reacts with the adjacent BH₃ subsituent, by cyclo-elimination, to give borinate **42** with regeneration of the oxazaborolidine **37**. In path 2, intermediate **40** reacts with a further molecule of BH₃ to give six membered BH₃ species **41** which decomposes to give the borinate **42** with regeneration of the oxazaborolidine-BH₃ complex **38**. Acidic work up of the borinate **42** affords the secondary alcohol product **43**. Because the oxazaborolidine-borane complex brings together the ketone substrate and reductant in an enzyme-like fashion it is described as a ‘chemzyme’.^{29,31} Using this reaction, Corey and co-workers were able to synthesize cdc25A protein phosphatase inhibitor dysidiolide **44** enantioselectively (Scheme 14).^{30,32}

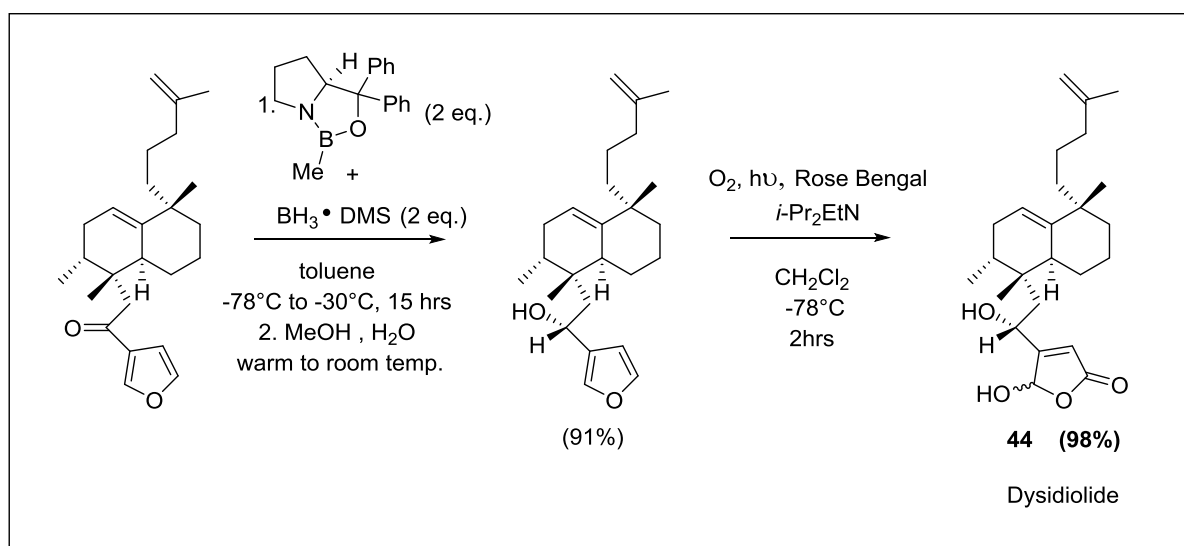

Scheme 14 Synthesis of Dysidiolide using a CBS reduction.³⁰

The Sharpless asymmetric epoxidation was discovered in 1981 by K.B. Sharpless and is an important asymmetric reaction.^{33,34} It is used to oxidise prochiral allylic alcohols to hydroxy epoxides, using titanium tetrakisopropoxide, L-(+)-diethyl tartrate (DET) as a chiral ligand and *tert*-butyl hydroperoxide as the oxidising agent. The reaction proceeds under mild conditions with good regio- and chemoselectivity and high enantioselectivity, usually greater than 90% enantiomeric excess.^{35,36} In the reaction mechanism, ligand exchange occurs between the titanium complex and DET, to form a C₂ symmetric dimer **45** with two titanium atoms bridged

by two DET ligands (Scheme 15). In order to form this dimer each titanium atom retains two of its isopropoxide ligands and is coordinated to one of the carbonyl groups of the tartrate ligand. Addition of the oxidising agent displaces one of the remaining isopropoxide groups and one of the DET carbonyl groups to give intermediate **46** (Scheme 15).^{35,36, 37}

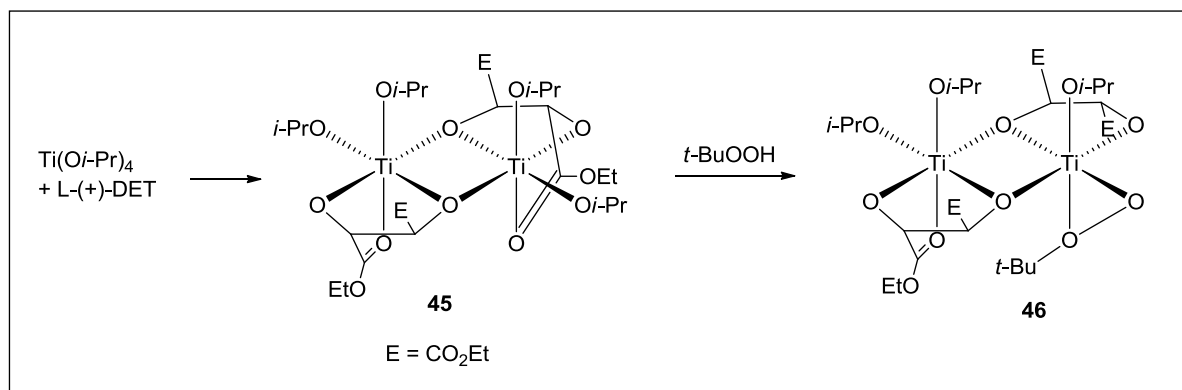

Scheme 15 Mechanism of the Sharpless asymmetric epoxidation.³⁷

Addition of the allylic alcohol displaces yet a further isopropoxide ligand with the hydroperoxide and the substrate occupying axial coordination sites on the metal to give intermediate **47** and based on mechanistic considerations, this is the catalytically active species.^{35,36} Delivery of the reactive oxygen, by the oxidant, then occurs from the lower face of the double bond of the substrate, *via* transition state **48** to give the epoxide product **49**, and this accounts for the facial selectivity. Only when both the allylic alkoxide and oxidant are bound to the complex can the epoxidation take place (Scheme 16).^{35,36}

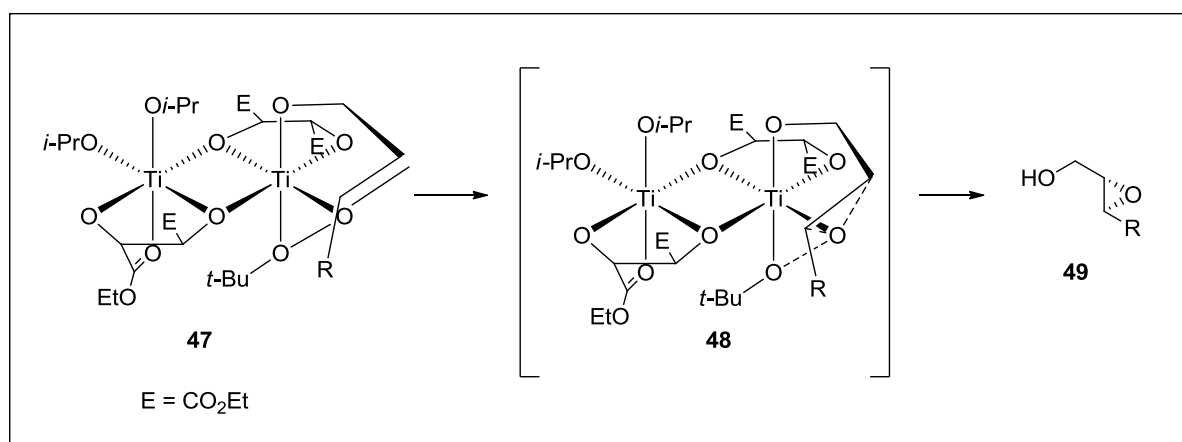

Scheme 16 Mechanism of the Sharpless asymmetric epoxidation.³⁵

The enantioselectivity of the reaction can be reversed by using D-(-)-tartrate, in which case delivery of the reactive oxygen occurs at the opposite enantiotopic face. The reaction has been applied to a wide range of allylic substrates and can also be used for the kinetic resolution of secondary allylic alcohols as well as for the preparation of epoxy alcohols.³² In a kinetic resolution where (*R,R*)-tartrate is used as the chiral ligand, the crude product will contain an excess of the slow reacting *R* enantiomer which can be recovered with a high level of enantiomeric purity and the relative reaction rates ($k_{\text{fast}} / k_{\text{slow}}$) for these kinetic resolutions range from 15-140.³⁶ The Sharpless asymmetric epoxidation was utilized in the total synthesis of the microtubule stabilising agent (-)-Laulimide **50** (Scheme 17).^{35,38}

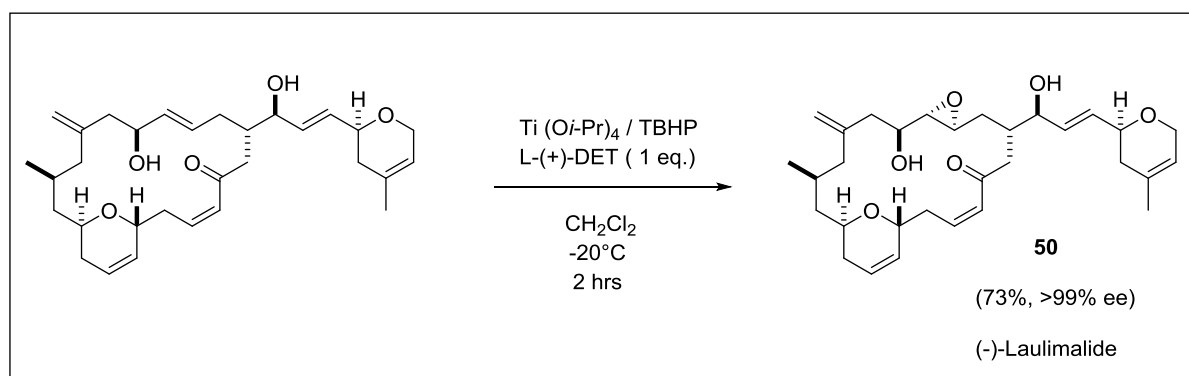

Scheme 17 Synthesis of (-)-Laulimide using a Sharpless epoxidation.³⁵

The Noyori asymmetric hydrogenation utilizes BINAP-Ru(II) complexes for the asymmetric hydrogenation of a wide range of functionalised olefins.³⁹ BINAP is a C_2 symmetric chelating diphosphine which binds a metal centre between its two phosphorus atoms to form a chiral complex.⁴⁰ BINAP is axially chiral due to restricted rotation about the bond joining the two naphthalene ring systems, and it therefore exists as a pair of enantiomers. It is prepared in the laboratory as a racemic mixture and then resolved by fractional recrystallization. One method of its preparation is shown below (Scheme 18).⁴¹

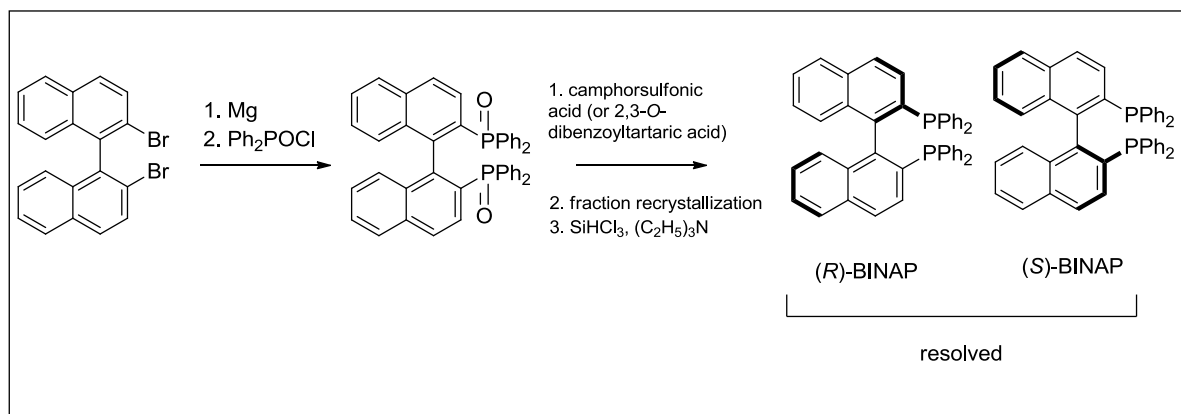

Scheme 18 Preparation of racemic BINAP.⁴¹

BINAP—Ru(II) dicarboxylate complexes are excellent catalysts for the enantioselective reduction of functionalised olefins such as α,β -unsaturated carboxylic acids, allylic alcohols and enamides.⁴¹ The reaction proceeds *via* a ruthenium monohydride intermediate due to heterolysis of molecular hydrogen by the ruthenium complex. The heteroatom of the functionalised olefin helps to tether the substrate to the metal centre and the enantioselectivity of the reduction arises from the fact that the substrate binds to the metal at only one of its two enantiotopic faces. Hydrogenation of the double bond occurs at this face to give an enantio-enriched product.⁴¹

Enamide **51** was stereoselectively hydrogenated in the presence of Ru-catalyst **53** to give methyl (*R*)- α -(acetamido)cinnamate **52** in 99% yield and >92% *ee* (Scheme 19).⁴² A model describing the reaction mechanism (with enamide **55**) is shown in Scheme 19. Molecular hydrogen undergoes heterolytic cleavage in the presence of (*R*)-BINAP-Ru(AcO)₂ to give the metal hydride species **54**, followed by substrate coordination to give intermediate **56**. The formation of intermediate **56**, which is a reversible step, leads to the formation of the more stable *Si*-**56** diastereoisomer, formed by coordination of the substrate at the *Si*-face. Delivery of a hydrogen atom from the metal complex to the double bond of the coordinated substrate occurs by a migratory insertion to give intermediate **57**.⁴² Finally, the configuration of the new stereogenic centre is defined by cleavage of the Ru-carbon bond. The enantiomeric ratio of the product **58** closely reflects the stability of the *Re* and *Si* diastereoisomers of intermediate **56** (Scheme 19).⁴²

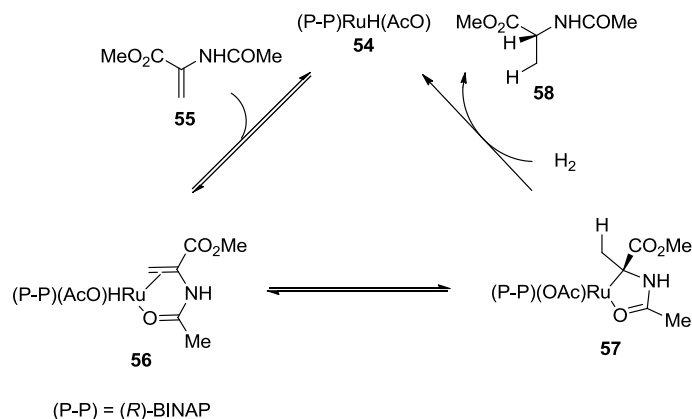
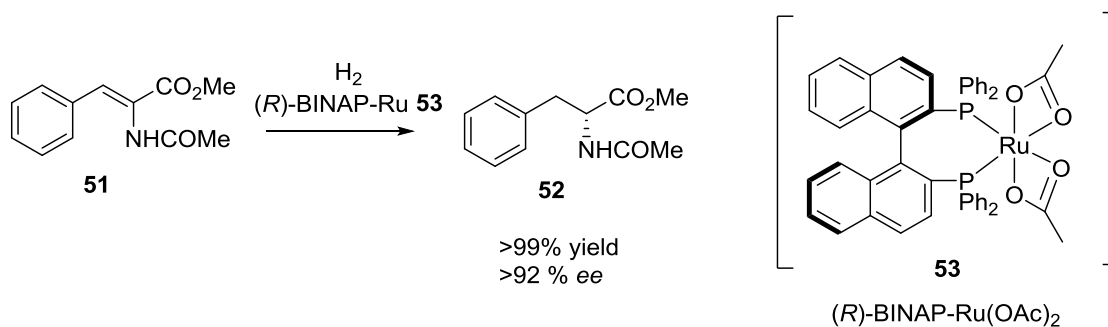

Scheme 19 Asymmetric hydrogenation of keto-enamide **55** in the presence of BINAP-Ru (II) complex **53**.⁴²

β -keto esters have been found to be the best substrates for BINAP-Ru(II) catalysed asymmetric hydrogenation, with enantiomeric excesses of up to 98%.⁴¹ The model shown in Scheme 20, gives a mechanism for the reduction of a generic β -keto ester **60** using a (*R*)-BINAP-Ru(II) catalyst (Scheme 20).⁴¹

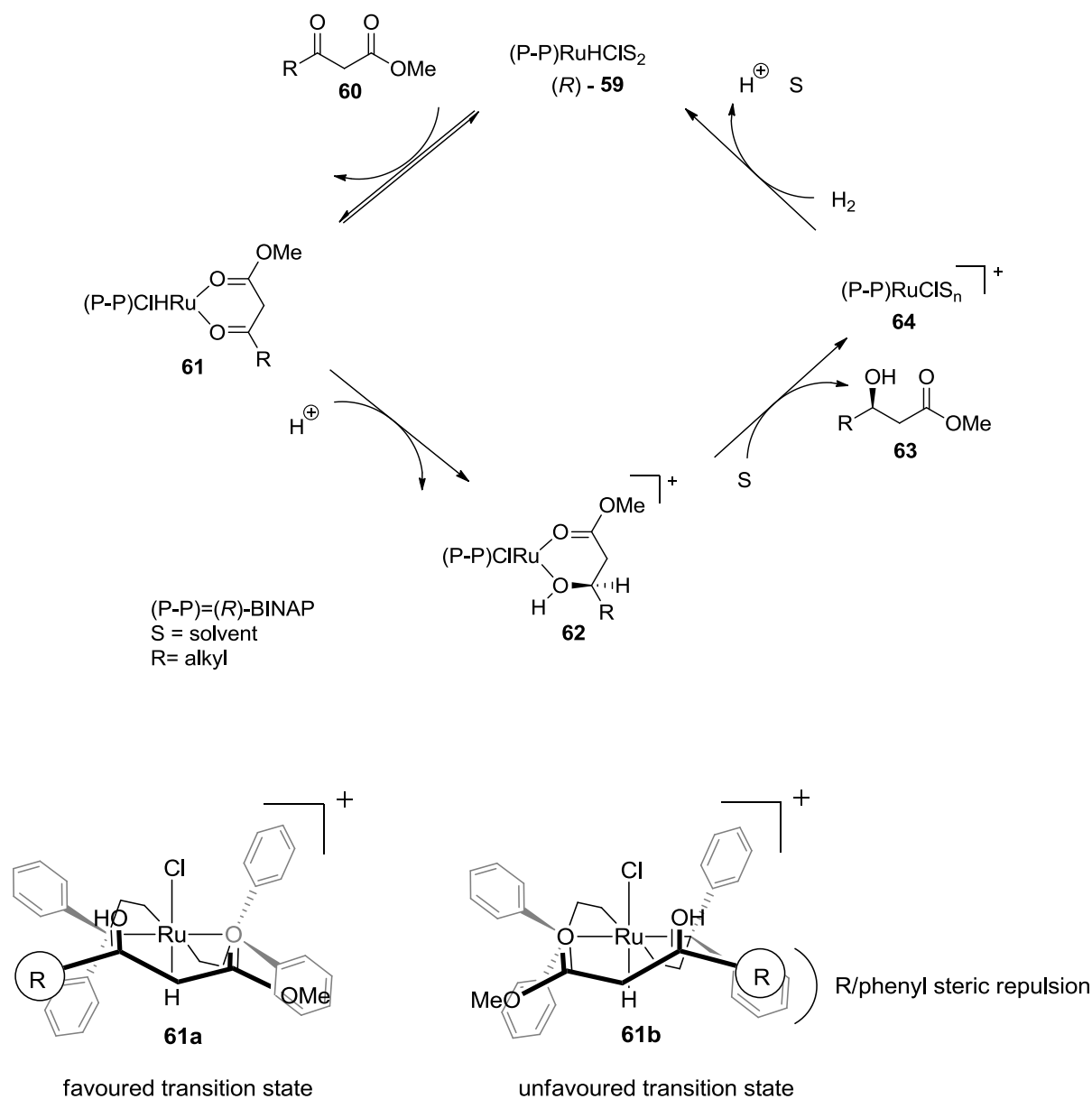

Scheme 20 Mechanism of the Noyori Asymmetric Hydrogenation of β -keto esters and structures of the transition states (naphthalene rings have been omitted for clarity).⁴¹

(*R*)-BINAP-RuCl₂(Sol)₂ (Sol = solvent) reacts with molecular hydrogen to generate H⁺ and RuHCl species **59** and also facilitates the transfer of hydride ion from the metal centre to the ketone carbonyl bond.⁴¹ Substrate coordination to the complex to give intermediate **61** involves two diastereomeric transition states. The higher energy transition state **61b** is unfavoured due to steric repulsion between the R group and the one of the phenyl groups of the (*R*)-BINAP ligand, whereas in the lower energy transition state **61a**, leading to product **63**, this repulsion is

absent, and this accounts for the enantioselectivity of the reaction, which can be reversed by using the (*S*)-BINAP-Ru complex which gives a product with the opposite configuration at the stereogenic centre.⁴¹ Transfer of hydride from the metal to the carbonyl group of the coordinated substrate is aided by protonation of the carbonyl oxygen by H⁺ (generated during the formation of the RuHCl species **59**), and gives intermediate **62** from which the hydroxyl ester product **63** is liberated by solvent (Scheme 20).⁴¹ Table 2 shows examples of the asymmetric reduction of β -keto esters using Noyori's catalyst.⁴³

Table 2 Noyori Asymmetric Hydrogenation of β -keto esters.⁴³

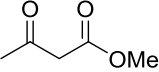
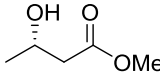
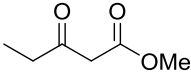
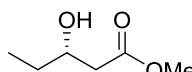
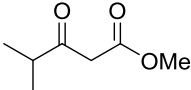
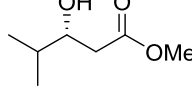
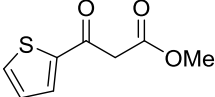
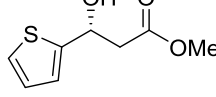
entry	substrate	conditions ^(a)	product	yield (%)	ee (%)
1		H ₂ (1 atm), Ru-(<i>S</i>)-BINAP (2 mol%) room temp., 48 hrs		80	97
2		H ₂ (1 atm), Ru-(<i>S</i>)-BINAP (2 mol%) 50°C, 3.5 hrs		100	99
3		H ₂ (1 atm), Ru-(<i>S</i>)-BINAP (2 mol%) 60°C, 48 hrs		100	97
4		H ₂ (1 atm), Ru-(<i>S</i>)-BINAP (2 mol%) 50°C, 3 hrs		100	87

(a) Reactions were performed in ethanol or methanol.

1.7 Organocatalysis

Organocatalysis, the catalysis of organic reactions by small organic molecules, is a field of research which has attracted much interest in recent years.⁴⁴ Until recently most catalysts used by chemists in the laboratory were metal based. Since the late 1990s however catalysis using non-metal based organic molecules has developed into a thriving area.^{45,46} Moreover, chiral derivatives of some of these catalysts can be used to obtain single enantiomers of desired chiral compounds with high levels of stereoselectivity.^{45,46} There is ongoing interest in the

development and use of chiral secondary amines as organocatalysts.⁴⁷ MacMillan's group have developed imidazolidinones such as **65**, which mimic aldolase type I enzymes.⁴⁸ Using 10-20 mol % of **65** they achieved high levels of enantioselectivity, of up to 97% *ee*, in an aldehyde-aldehyde aldol reaction. The imidazolidinone reacts with the aldehyde to form enamine-iminium ion **66**, which is then attacked by a second molecule of the substrate to form the carbon-carbon bond. The enamine-iminium ion **66** adopts the *E* geometry in order to avoid nonbonding interactions with the nearby tertiary butyl group. Carbonyl addition then occurs at the less hindered *Si* face of the enamine-iminium ion, with the aldehyde reacting preferentially at one of its two enantiotopic faces, to give the aldol product **67** and this accounts for the stereoselectivity (Scheme 21).⁴⁸

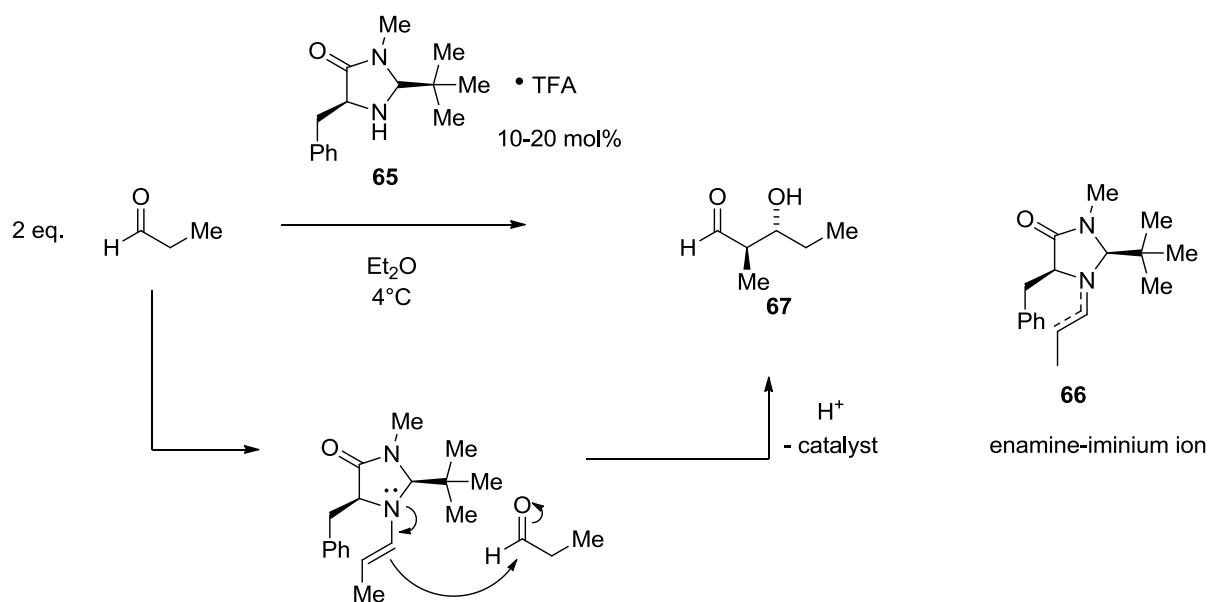

Scheme 21 Imidazolidinone-catalyzed direct aldol condensation (in the above mechanism the enamine-iminium ion is depicted in its enamine form for clarity).⁴⁸

Table 3 Imidazolidinone-catalyzed direct aldol condensation.⁴⁸

10-20 mol % **65**
Et₂O, 4°C
Amberlyst-15, MeOH

entry	R ¹	R ²	product	yield(%) ^(a)	<i>anti</i> / <i>syn</i> ^(b)	ee(%) ^(c,d)
1	Me	Me		86	4:1	94
2	Me	<i>i</i> -Pr		90	5:1	95
3	Me	<i>c</i> -C ₆ H ₁₁		81	5:1	97
4	Me	Ph		61	4:1	93
5	<i>n</i> -Bu	<i>i</i> -Pr		72	6:1	91

(a) Absolute and relative stereochemistry assigned by chemical correlation. (b) Determined by chiral GLC or Mosher ester analysis. (c) Enantiomeric excess of major diastereoisomer. (d) Performed in dioxane.

The MacMillan group have also reported an enantioselective catalytic Diels-Alder reaction which they applied to a range of ketone dienophiles and dienes using 20 mol % of imidazolidinone **68**.⁴⁹ The imidazolidinone reacts with a molecule of the ketone dienophile to form an iminium ion, thereby lowering the energy of the LUMO of the substrate. The iminium ion is then attacked by the diene in a [4+2] cycloaddition to give the Diels-Alder product **69** (Scheme 22). Using imidazolidinone **68** they obtained very good diastereomeric and

enantiomeric selectivity in the reaction between ethyl vinyl ketone and various dienes, as shown in Table 4.⁴⁹

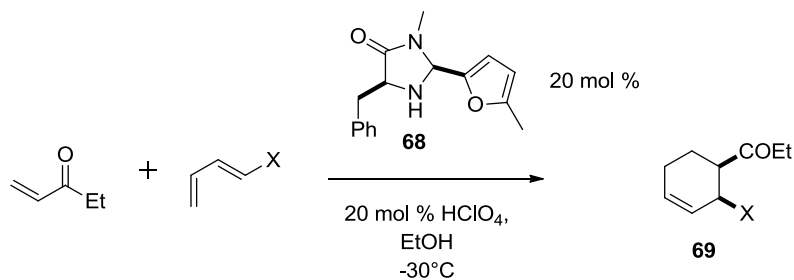

Scheme 22 Organocatalysed Diels-Alder reaction between ethyl vinyl ketone and representative dienes.⁴⁹

Table 4 Organocatalysed Diels-Alder reaction between ethyl vinyl ketone and representative dienes.⁴⁹

entry	diene	product	<i>endo</i> : <i>exo</i>	% yield	% <i>ee</i> ^{a,b}
1.			>200:1	88	96
2.			>100:1	91	98
3. ^c			>200:1 ^d	92	90
4.			>200:1	90	90
5. ^e			>200:1 ^d	79	83 ^f

(a) Product ratios determined by chiral GLC or HPLC. (b) Absolute configuration determined by chemical correlation to a known compound or by analogy. (c) Reaction conducted at -40°C. (d) Regioisomeric ratio. (e) Reaction conducted at -20°C. (f) Reaction performed without solvent.

1.8 Proline Catalysis

Sparr and co-workers have reported the stereoselective epoxidation of α,β -unsaturated aldehydes using chiral catalyst **70** derived from (*S*)-proline.⁵⁰ X-ray diffraction data indicates that the iminium ion **71** adopts the *E* geometry in order to minimise 1,3-allylic strain.⁵⁰ Also, the presence of the fluorine substituent β to the nitrogen, induces the iminium ion **71** to undergo a conformational change known as a '*gauche* effect' with a torsional angle of 57° between the fluorine and nitrogen atoms.⁵⁰ In this conformation, one of the phenyl groups is positioned across one face of the π -system of the iminium ion **71**, which accounts for the high levels of enantiofacial discrimination in the addition of the hydrogen peroxide oxidising agent to the π bond of the iminium ion. Also, the fluorine substituent is believed to interact with the LUMO of the same π bond, and thereby lower its energy (Scheme 23).⁵⁰

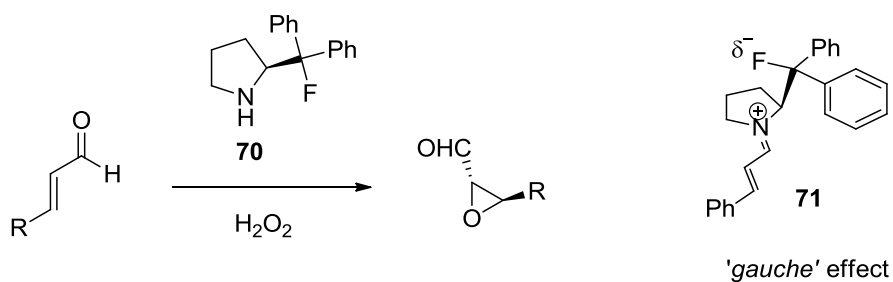

Scheme 23 The catalytic epoxidation reaction using chiral catalyst **70**.⁵⁰

Table 5 The scope of the catalytic epoxidation reaction.^{50,(a)}

entry	substrate	yield (%) ^(b)	<i>d.r.</i> ^(c)	<i>ee</i> (%) ^(d)
1	R = Ph	92	82:18	96
2	R = <i>p</i> -FC ₆ H ₄	89	73:27	94
3	R = <i>p</i> -BrC ₆ H ₄	94	81:19	94
4	R = <i>p</i> -NO ₂ C ₆ H ₄	93	69:31	96
5	R = <i>p</i> -MeOC ₆ H ₄	26 ^(e)	-	-
6	R = <i>n</i> -Pr	87 ^(f)	92:8	95
7	R = <i>i</i> -Pr	90 ^(f)	>95:<5	92
8	citral ^(g)	91	60:40	81
9	cyclohexene-1-carboxaldehyde	68	>95:<5	97

(a) Reactions performed in CHCl₃ with aldehyde (500 μmol), amine **70** (10 mol%), and H₂O₂ (1eq.) for 3 hrs at room temp. (b) Yield of isolated product. (c) Determined by ¹H NMR spectroscopy. (d) Determined by GC and HPLC analysis on a chiral stationary phase. (e) The ring opened glyoxal was obtained after 14 hrs. (f) After reduction using NaBH₄. (g) *E/Z* 3:2

Chiral systems derived from (*S*)-proline, namely the Enders hydrazone, the Corey CBS catalyst and chiral proline derivative **70**, used in the stereoselective epoxidation of α,β-unsaturated aldehydes, have already been discussed. (*S*)-Proline **72** itself has been employed as a chiral catalyst in important reactions such as the aldol reaction, the Mannich reaction and the Michael addition, and this area has been reviewed by B. List.⁵¹ The obvious advantages of (*S*)-proline as a catalyst are its natural abundance and its availability in both enantiomeric forms. In the early 1970s Hajos and Parish reported the (*S*)-proline catalysed intramolecular aldol reactions of certain triketones.⁵² This work was subsequently extended to the intermolecular aldol reaction of aldehydes and ketones and has been applied to a wide range of aldehydes by B. List and coworkers.⁵³ One limitation of this reaction is that a large excess of the ketone is required (about 20 equivalents) which means that only small inexpensive ketones such as acetone and butanone are typically used. Table 6 shows examples of asymmetric aldol reactions of aldehydes with acetone catalyzed by (*S*)-proline (Table 6).⁵¹

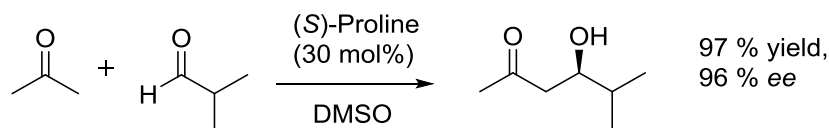

Scheme 24 The (*S*)-proline catalysed Aldol reaction.⁵¹

Table 6 The (*S*)-proline catalysed Aldol reaction.⁵¹

product	yield (%)	ee (%)
	62	76
	63	84
	81	>99
	85	>99

The mechanism of the (*S*)-proline catalysed asymmetric aldol reaction is believed to proceed *via* the formation of carbinolamine **73**, (formed by reaction of (*S*)-proline with the ketone substrate) leading to the formation of the iminium ion **74** (with loss of a water molecule) which is in equilibrium with its enamine form.⁵¹ This is followed by *re*-facial attack by the aldehyde on the enamine, in which the carboxyl group is hydrogen bonded to the oxygen of the aldehyde carbonyl bond, leading to the formation of intermediate **75**, and this step accounts for the enantioselectivity of the reaction. Hydrolysis of this intermediate leads to the β -hydroxyketone product **76** (Scheme 25).⁵¹

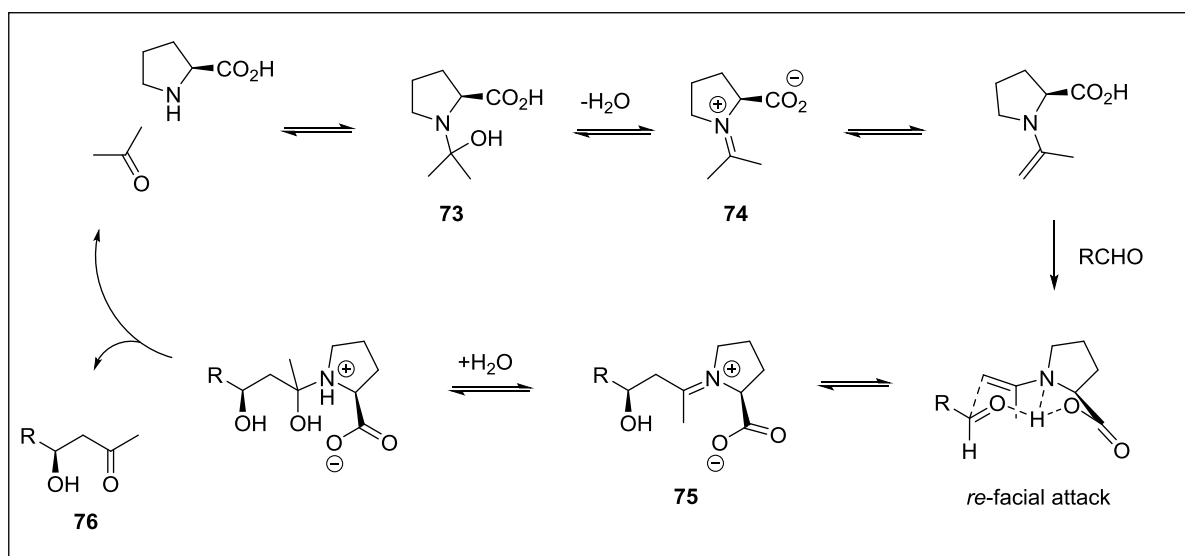







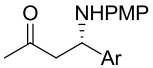

Scheme 25 Mechanism of the L-proline catalyzed Aldol reaction.⁵¹

In the Mannich reaction an aldehyde, a ketone and an amine react to form a β -aminoketone.⁵¹ Catalytic Mannich reactions used to require pre-formed imine and enol equivalents until it was discovered that (*S*)-proline could be used as an asymmetric catalyst for this reaction with high yields and diastereoselectivities.^{51,53} The List group have explored the substrate scope of this reaction and applied it to a broad range of aldehydes, while *p*-anisidine was found to be the most reactive amine component.⁵⁴ Table 7 shows the products obtained from the (*S*)-proline catalyzed Mannich reaction of various ketones with *p*-anisidine and *p*-nitrobenzaldehyde.^{51,53}

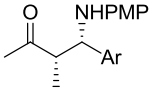

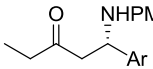
Scheme 26 The (*S*)-proline catalyzed Mannich reaction.⁵³

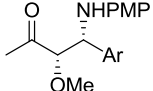
Table 7 The (*S*)-proline catalysed Mannich reaction.⁵³

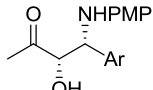
ketone	products	yield (%)	de (%)	ee (%)
		50	-	94
	 (2.5:1)	96	>95	99
		-	-	94
		93	>95	98
		92	>95	>99

In the mechanism for this reaction, (*S*)-proline reacts with a molecule of the ketone to form an enamine, which attacks the imine (formed by reaction of the aldehyde with the amine component) to give intermediate **77**. This intermediate is hydrolysed to afford a β-aminoketone with regeneration of the (*S*)-proline catalyst (Scheme 27).⁵³

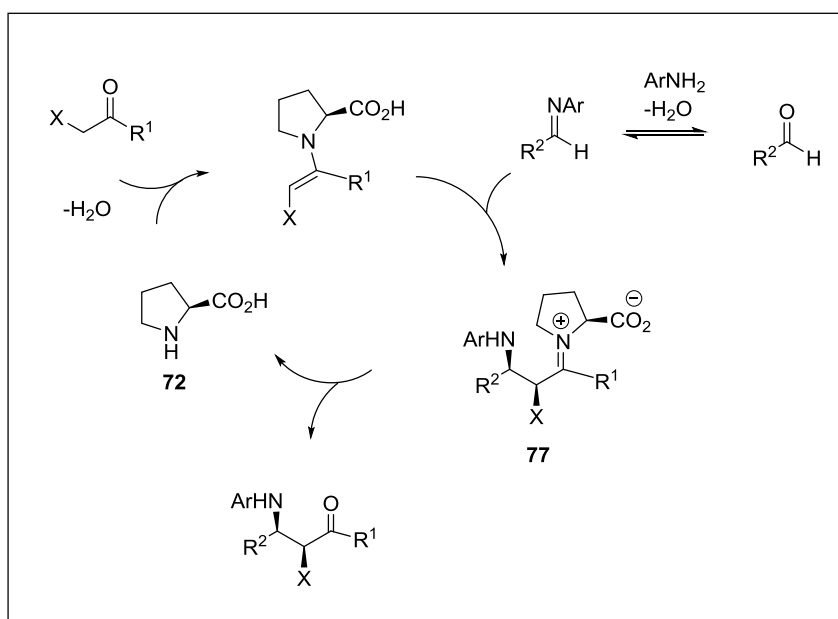

Scheme 27 Mechanism of the (*S*)-proline catalysed Mannich reaction.⁵³

1.9 Asymmetric formylation

Scolastico and co-workers have reported the asymmetric electrophilic α -formylation of carbonyl compounds using the nor-ephedrine derived orthoamide **78** as a chiral auxiliary.⁵⁵ The racemic carbonyl compound is converted into a silyl enol ether or an enamine, and this is reacted with the orthoamide **78** (where the nitrogen is protected by a Cbz or Ts group) in the presence of the Lewis acid $\text{BF}_3 \cdot \text{Et}_2\text{O}$ to give compound **79** as a diastereomeric mixture which contains predominantly one of the two isomers. Subsequent removal of the chiral auxiliary gives an α -formylated carbonyl compound containing a quaternary centre. The researchers used this methodology to prepare the unstable β -ketoaldehyde **80**, which they converted *in situ* to ester **81** by a Wittig reaction (Scheme 28).⁵⁵

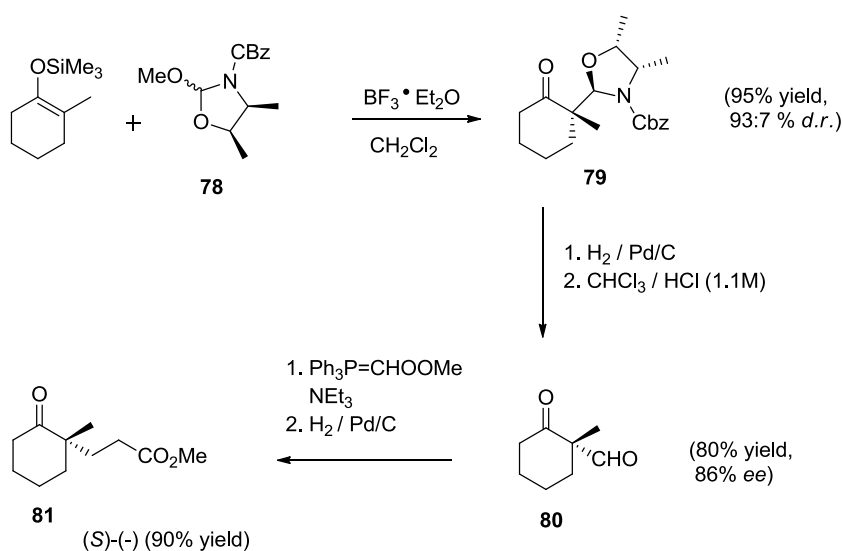

Scheme 28 Addition of enamines and silyl enol ethers to orthoamide **78** in the presence of $\text{BF}_3 \cdot \text{Et}_2\text{O}$.⁵⁵

Table 8 Addition of enamines and silyl enol ethers to orthoamide **78** in the presence of $\text{BF}_3 \cdot \text{Et}_2\text{O}$.⁵⁵

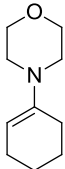
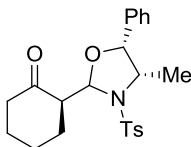
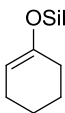
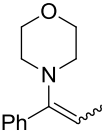
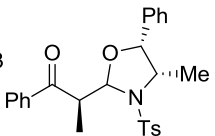
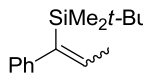
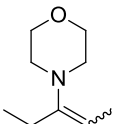
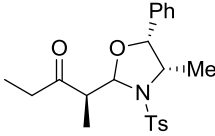
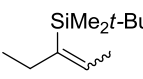
entry	enamine	major diastereoisomer ^a	silyl enol ether
1.		$d.r. = 84/16$ 88% yield 	$d.r. = 43/57$ 95% yield 
2.		$d.r. = 87/13$ 90% yield 	$d.r. = 71/29$ 95% yield 
3.		$d.r. = 91/9$ 90% yield 	$d.r. = 95/5$ 56% yield 

(a) Ratios were determined by ^1H NMR spectroscopy

Yields reported here refer to the diastereomeric mixtures isolated after chromatography

Cozzi and co-workers, have reported the stereoselective α -formylation of ketones.⁵⁶ They reacted various cyclic ketones with *N*-methylbenzothiazolium iodide **82** (employed as a formyl cation equivalent), in the presence of a catalytic quantity of chiral amine base **83**, to give intermediate **84**, with high levels of stereoselectivity. The ketone reacts with the chiral amine **83** to form a primary enamine. It is suggested that this enamine is attacked, by the *N*-methylbenzothiazolium, face selectively, to give intermediate **84**. Hydrolysis of intermediate **84** affords the formylated product (Scheme 29).⁵⁶

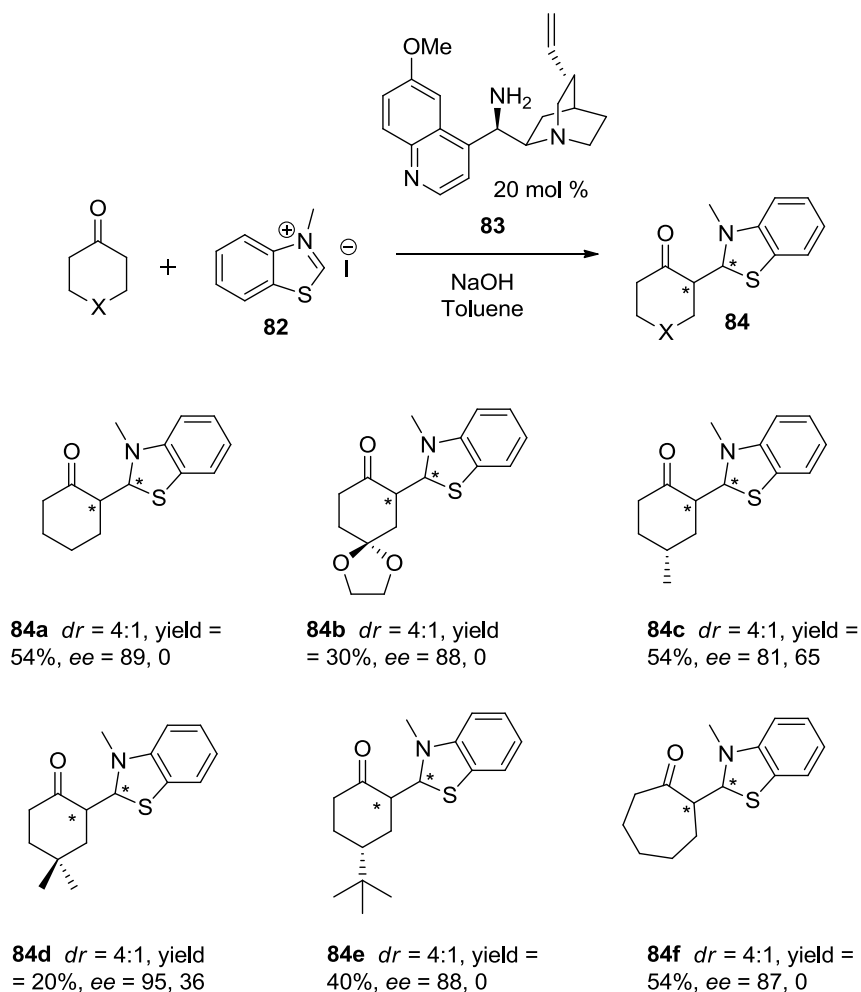

Scheme 29 Catalyst promoted addition of various cyclic ketones to the *N*-methylbenzothiazolium iodide using chiral amine base **83** as catalyst.⁵⁶

The absolute configuration of the newly formed stereogenic centres was determined by chemical correlation with a compound whose absolute configuration was known.⁵⁶ For example; cyclohexanone reacted with *N*-methylbenzothiazolium iodide **82**, in the presence of a catalytic quantity of chiral amine base **83** to give intermediate **85**. Reduction of this intermediate with sodium borohydride, followed by hydrolysis with silver nitrate in acetonitrile-phosphate buffer (0.05M, pH 7), gave the unstable aldehyde **86**, which was further reduced with sodium borohydride to give (1*R*-2*R*)-2-hydroxycyclohexanemethanol **87** which is a known compound (Scheme 30).⁵⁶

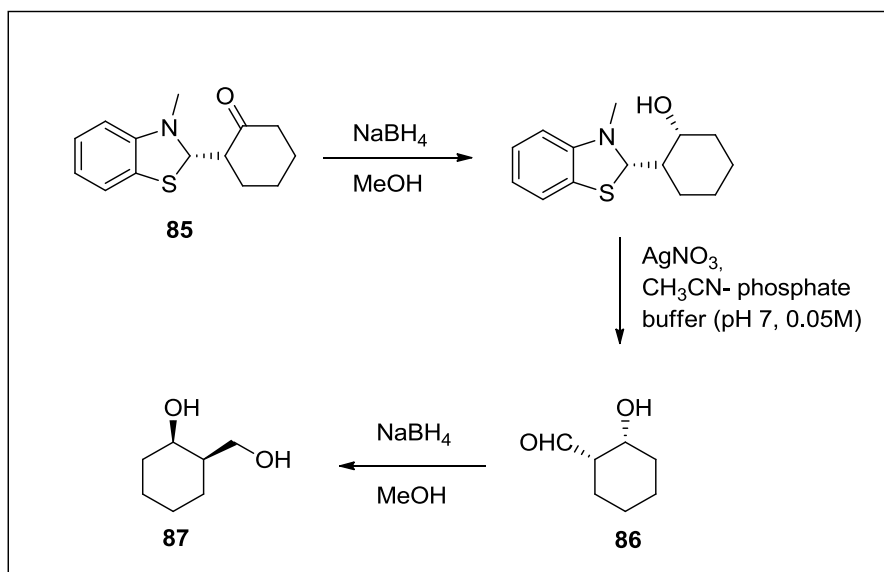

Scheme 30 Determination of absolute configuration by correlation with a known compound.⁵⁶

The Enders group have reported the stereoselective synthesis of α -substituted- β -formyl- δ -formyl lactones from 2-pentenolide, using SAMP hydrazone **89** as a chiral formyl anion equivalent.⁵⁷ The α,β -unsaturated lactone **88** reacted with the chiral hydrazone **89** in a 1,4 Michael addition to give adduct **90**, in the presence of the Lewis acid TBSOTf, which activated the enone as a Michael acceptor. This was followed by an α -alkylation, *via* a lithium enolate, to form compound **91** and finally ozonolysis to remove the chiral auxiliary gave product **92** with good stereocontrol in all three steps of the reaction (Scheme 31).⁵⁷

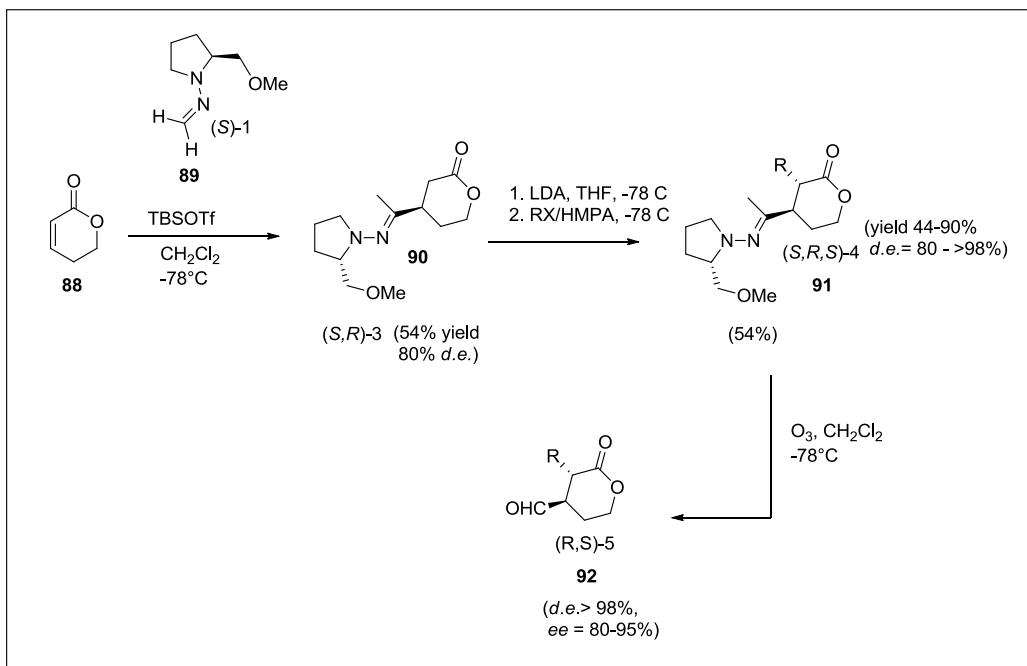

Scheme 31 Asymmetric α -alkylation / β -formylation using formaldehyde SAMP hydrazone.⁵⁷

Table 9 Asymmetric α -alkylation / β -formylation using formaldehyde SAMP hydrazone.⁵⁷

entry	RX	yield of 91 (%)	$d.e.$	yield of 92 (%)	ee
1	AllylBr	90	>98, (98)	-	-
2	MeI	89	80, (78)	70	82
3	BnBr	77	80, (>98)	59	80
4	<i>n</i> -Pri	67	88, (74)	68	89
5	TBSO(CH ₂) ₂ I	44	94, (59)	50	95

(a) The figures in brackets refer to the yields for the alkylation reactions.

(b) Material decomposed during ozonolysis.

2. Vilsmeier-Haack Formylation

The aim of this project was to devise a new protocol for the asymmetric α -formylation of ketones, built upon the Vilsmeier-Haack protocol. Therefore, the origin and development of the Vilsmeier-Haack reaction will be described in this section of the introduction.

2.0.1 Introduction

In 1927 Anton Vilsmeier and Albecht Haack published a paper in which they reported the formylation of *N,N*-dimethylaniline using a chloroiminium salt derived from *N*-methylformanilide and phosphoryl chloride to give 4-dimethylaminobenzaldehyde.⁵⁸ This reaction, known as a Vilsmeier-Haack formylation, can be described a special type of Friedel-Crafts acylation,⁵⁹ and is now a common method to formylate activated aromatic rings containing an electron donating group (Scheme 32).⁶⁰

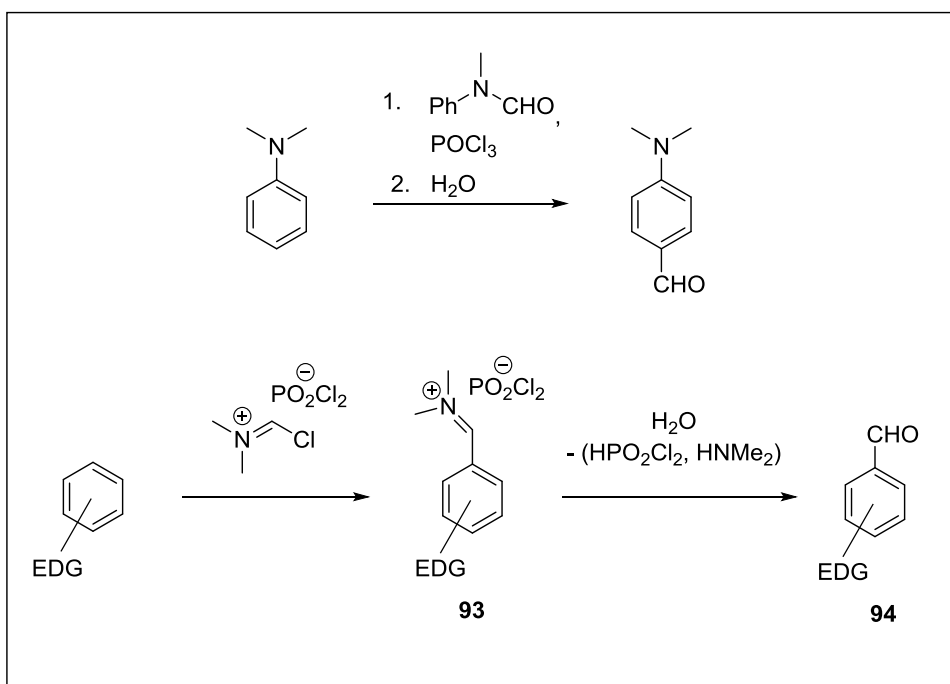

Scheme 32

The chloroiminium salt derived from the reaction of a substituted amide, such as *N,N*-dimethylformamide (DMF) or *N*-methylformanilide (MFA), with an acid halide, is called a ‘Vilsmeier reagent’ and is a weak electrophile.⁶⁰ Typically, DMF is reacted with phosphoryl chloride, in a halogenated solvent, at temperatures between 0-80°C, to generate the chloroiminium salt **96**, which is stable enough to be isolated.⁶¹ Initially intermediate **95** is formed, followed by expulsion of PO₂Cl₂ anion to generate the active species **96** (Scheme 33).⁶¹

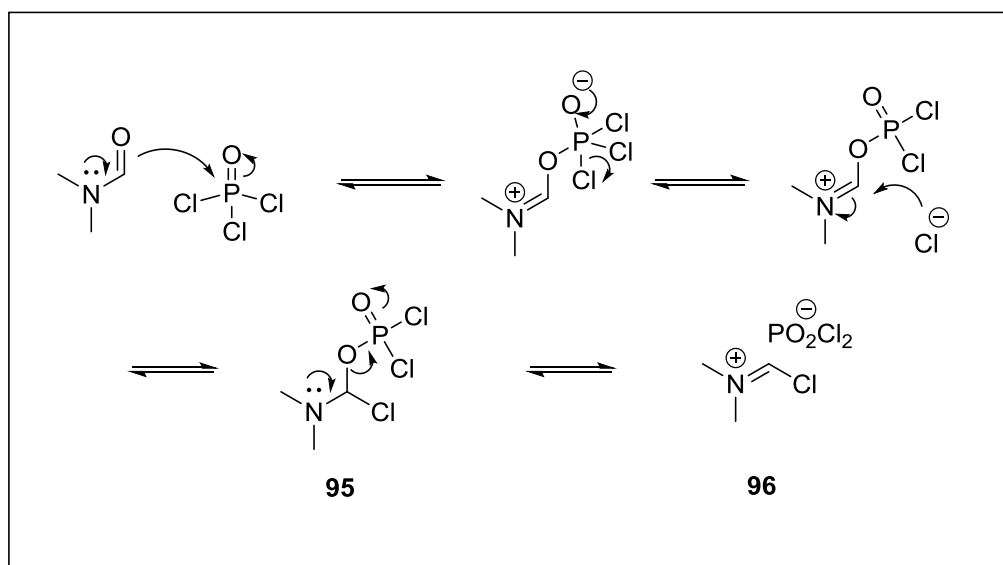

Scheme 33 Mechanism of the generation of a Vilsmeier reagent.⁶¹

The chloroiminium salt reacts with an activated substrate, typically a benzene derivative containing an electron donating group, to give an intermediate which is hydrolysed during aqueous work up to afford a formylated product. The mechanism of the formylation of *N,N*-dimethylaniline (at the *ortho* position) is shown in Scheme 34. The substrate needs an activating group because the Vilsmeier salt is a weak electrophile, and so an electron donating group increases the nucleophilicity of the substrate and also stabilises the cationic intermediate formed after the initial attack of the electrophile. The rate determining step in the Vilsmeier formylation can be either the formation of the chloroiminium salt, or its subsequent reaction with the substrate, depending on the reactivity of the substrate.⁶²

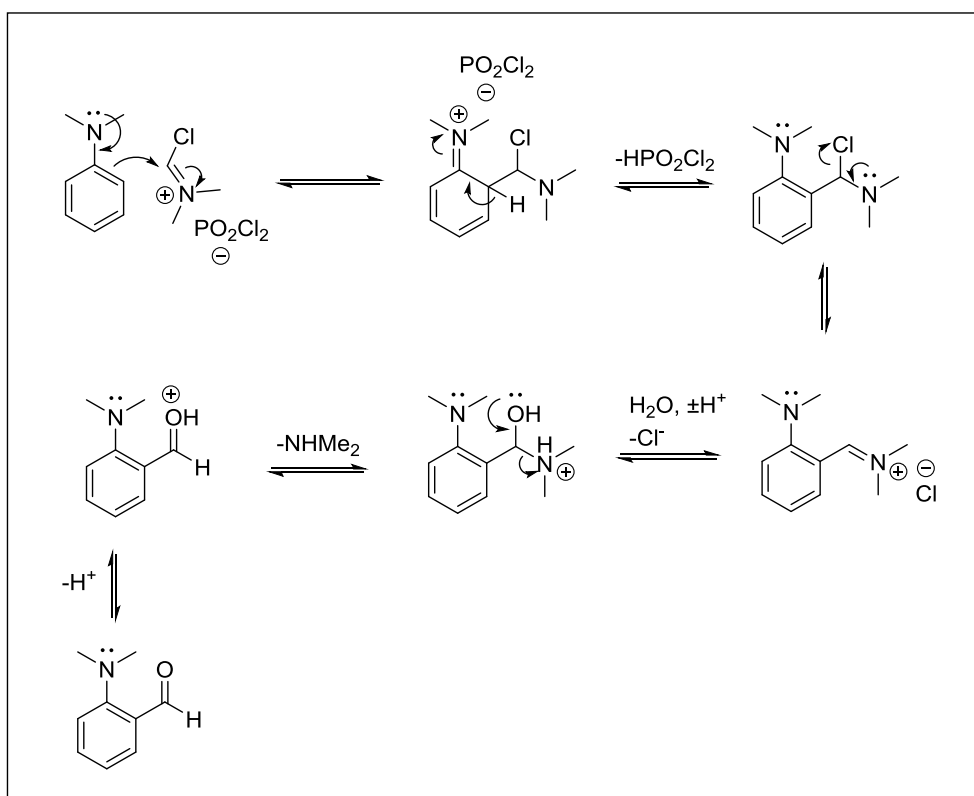

Scheme 34 Vilsmeier formylation of *N,N*-dimethylaniline.

It has been suggested that the formation of the iminium salt **96** from DMF and phosphoryl chloride involves a series of equilibria, as indicated in Scheme 35.⁶¹ Initially intermediate **97** is formed, followed by expulsion of either PO_2Cl_2 anion or chloride ion to give salts **96** or **98** respectively (Scheme 35).⁶¹

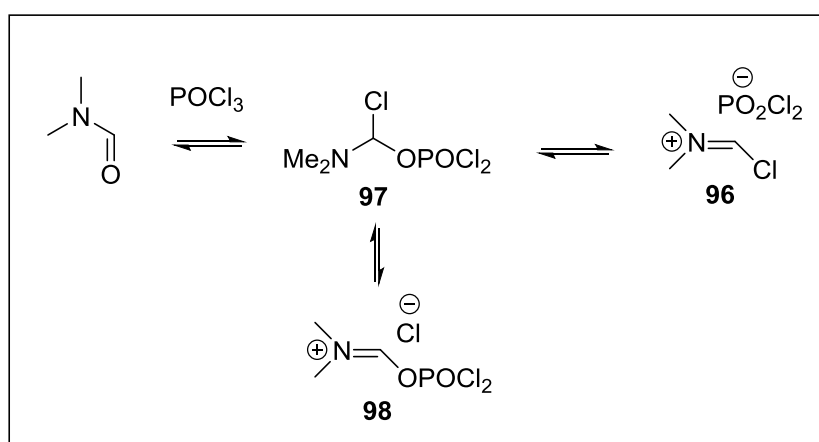

Scheme 35

If DMF is present in excess then it may react with **96** to give species **100**. It is argued that the driving force for this process is the generation of the lower energy (and less reactive) salt **100** (Scheme 36).⁶¹

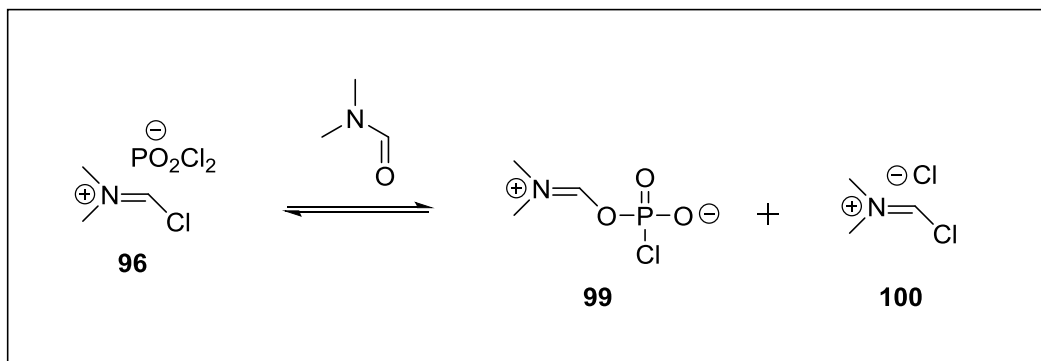

Scheme 36

However, if pyrophosphoryl chloride is used, instead of POCl_3 , then the process leading to the formation of **100** is no longer possible, and the active species is the more reactive salt **101** (Scheme 37).^{61,68} When oxalyl chloride is used as the acid halide then chloroiminium salt **100** is formed irreversibly with the expulsion of thermodynamically stable gases (Scheme 37).⁶⁸

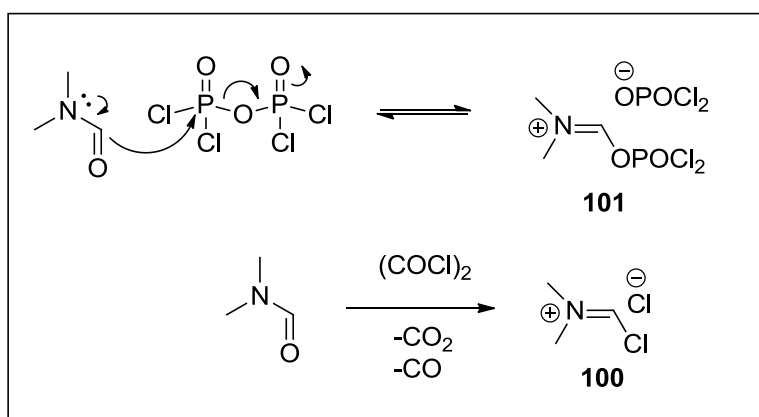

Scheme 37

Vilsmeier reagents derived from substituted amides other than formamides, react with substrates to give ketones in low yield.⁶¹ Other reagents typically used to generate the iminium salt include thionyl chloride and carbonyl chloride.^{63,64} Thionyl chloride reacts with DMF to

form iminium salt **102** which, when heated, loses SO₂ irreversibly to give a the stable crystalline salt **103**, and both salts **102** and **103** have been characterised.⁶⁵ The Vilsmeier reagent is sometimes represented by resonance structures, where the active species is represented either as the iminium salt **104**, or as the carbocation **105** (Scheme 38).⁶⁶

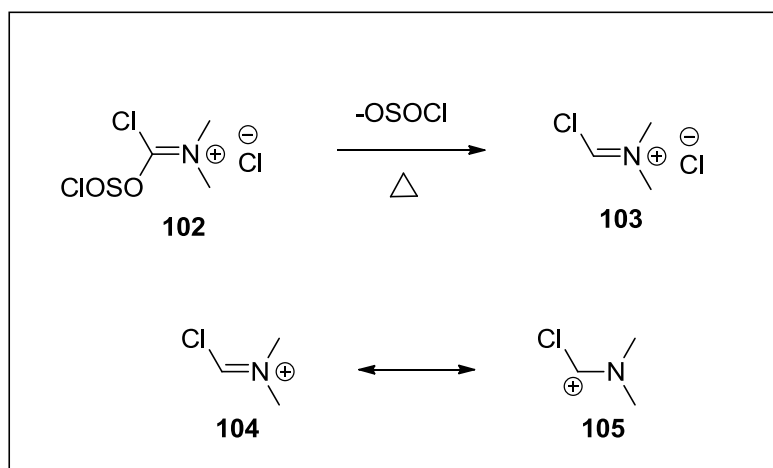





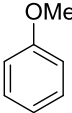

Scheme 38

2.0.2 Aromatics substrates

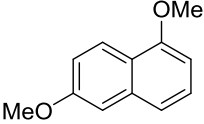
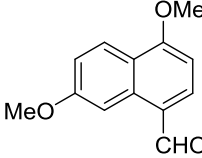
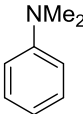
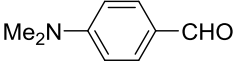
A range of electron rich aromatic and heteroaromatic substrates have been successfully formylated using the Vilsmeier reagent and they include *N,N*-dialkylanilines, *O*-alkylated phenols, naphthalenes, indoles, pyrroles, furans, thiophenes and selenophenes, and this has been well reviewed by Jones and Stanforth.⁶¹ Table 10 shows the major products obtained from the Vilsmeier formylation of various aromatic and heteroaromatic compounds (Table 10).⁶¹

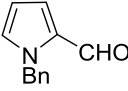
Table 10 The Vilsmeier formylation of various aromatic and heteroaromatic compounds.

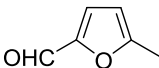
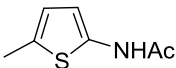
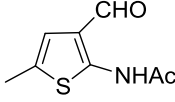
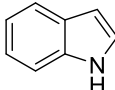
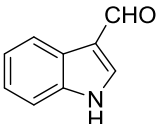
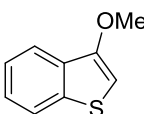
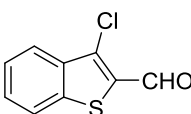
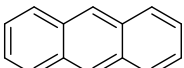
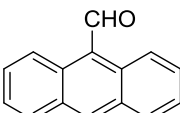
entry	substrate	reagent	product	yield	ref.
1.		MFA / P ₂ O ₃ Cl ₄		73	67
2.		DMF / POCl ₃		61	61
3.		DMF / P ₂ O ₃ Cl ₄		99	67
4.		DMF / POCl ₃		86.5	67
5.		DMF / P ₂ O ₃ Cl ₄		77	68
6.		DMF / POCl ₃		62	61
7.		DMF / P ₂ O ₃ Cl ₄		97	68
8.		MFA / POCl ₃		90	61
9.		DMF / POCl ₃		92	69

Monosubstituted benzenes, such as aniline and anisole, undergo formylation at the 4-position, though small amounts of 2-formyl anisole have been observed in the reaction of anisole with DMF/POCl₃, which can be attributed to the relative lack of steric hindrance of the substrate to the chloroiminium salt.⁶¹ Indeed, the ratio of 4-formylanisole : 2-formyl anisole was larger when anisole was reacted with the sterically bulkier chloroiminium salt derived from *N*-methylformanilide (MFA) and pyrophosphorylchloride (Scheme 39).^{61,68} In the presence of excess DMF/POCl₃ *N,N*-dimethylaniline reacts to give a small amount of 2,4-diformylated product as well as the monoformylated product.⁶⁸

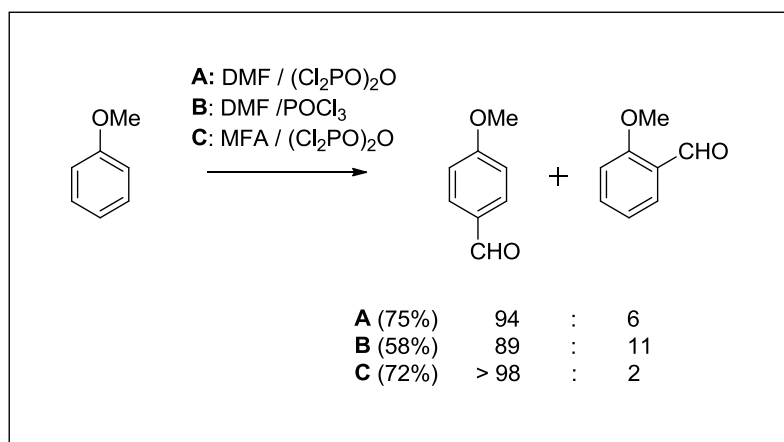

Scheme 39 Vilsmeier formylation of anisole.⁶¹

In di- and polysubstituted benzenes, the position of formylation depends upon the relative directing power of the substituents, as illustrated by the reaction of the trisubstituted compound **106** with MFA/ POCl₃ (Scheme 40).^{61,70}

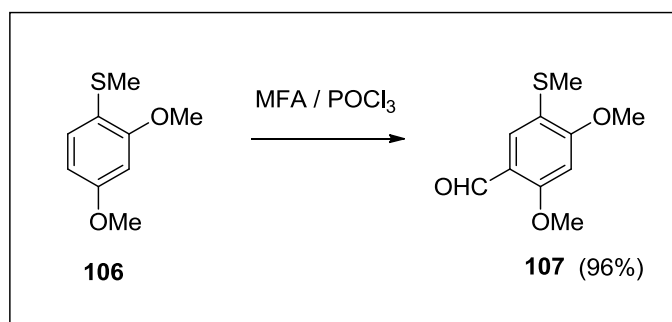

Scheme 40 Relative directing power of substituents in Vilsmeier formylation of trisubstituted aromatic compound **107**.⁶¹

Para-substituted tertiary anilines **108** have been reacted with iminium salts, derived from *N*-formylated tertiary anilines **112** and POCl₃, to give dibenzo[1,5]diazocines **111** by way of an interesting process known as ‘the tertiary amino effect’.^{71,72} In the first step, the iminium salt attacks the substrate at the *ortho* position to give intermediate **109**. This is followed by abstraction of a hydride ion, in a 1,5 sigmatropic shift, to give intermediate **110**, and finally cyclisation occurs to give the dibenzo[1,5]diazocine **111** (Scheme 41).^{71,72}

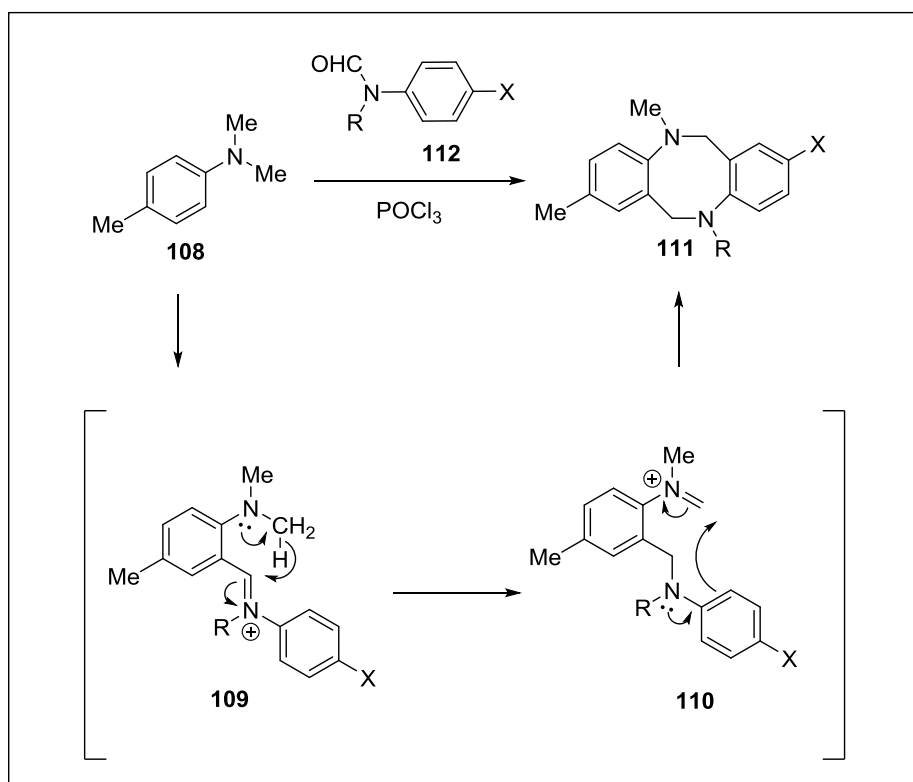

Scheme 41 Formation of dibenzo[1,5]diazocines by way of a ‘tertiary amino effect’.⁷¹

2.0.3 Heteroaromatic substrates

The reactions of pyrroles, furans, thiophenes, and their annulated analogues, with Vilsmeier reagents have been extensively researched and their relative reactivities are in that respective order.⁶¹ The position of formylation of monosubstituted pyrroles is found to depend on both steric and electronic effects.^{61,73} Usually *C*-substituted pyrroles undergo monoformylation at a free 2-position, though the presence of an electron-withdrawing group at the 2-position can direct formylation to the 4 position. Experiments with *N*-alkylated pyrroles showed that steric hindrance at the 1-position directs formylation to the 3-position.⁷³ The formylation of *N*-

methylpyrrole gave entirely the α -formyl product whereas when *N*-isopropylpyrrole and *N*-*tert*-butylpyrrole were formylated under the same conditions, the ratio of α : β formyl isomers was 1.9:1 and 1:14 respectively. The table below shows the steric effect in the formylation of various 1-substituted pyrroles (Table 11).⁷³

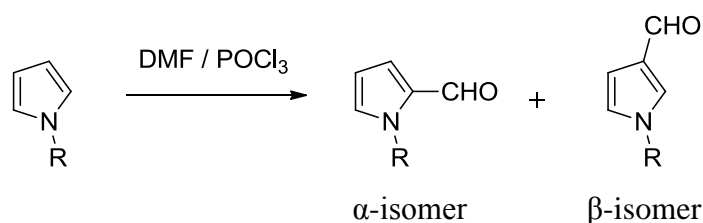

Scheme 42 Formylation of various 1-substituted pyrroles.⁷³

Table 11 Formylation of various 1-substituted pyrroles.⁷³

1-Substituent	overall yield of formylated products (%)	ratio of α : β isomers
Methyl	89	100 % α
ethyl	85	11.5 : 1
isopropyl	79	1.9 : 1
<i>t</i> -butyl	69	1 : 14
benzyl	89	6.2 : 1

Monosubstituted furans and thiophenes also undergo monoforylation at a free α -position.⁶¹ As in the case of pyrroles, the position of formylation of disubstituted furans and thiophenes depends on the relative electron-donating power of the substituents;^{61,74} Indole, the most reactive of the annulated heterocycles, reacts with Vilsmeier reagent to undergo formylation at the 3-position, though it can be forced to react at the 2-position by the use of a 1,3 disubstituted substrate.^{75,76} 3-Substituted indoles usually give *N*-formyl products, but highly activating substituents at the 3 position give formylation at the 2-position. (Scheme 43).^{77,78}

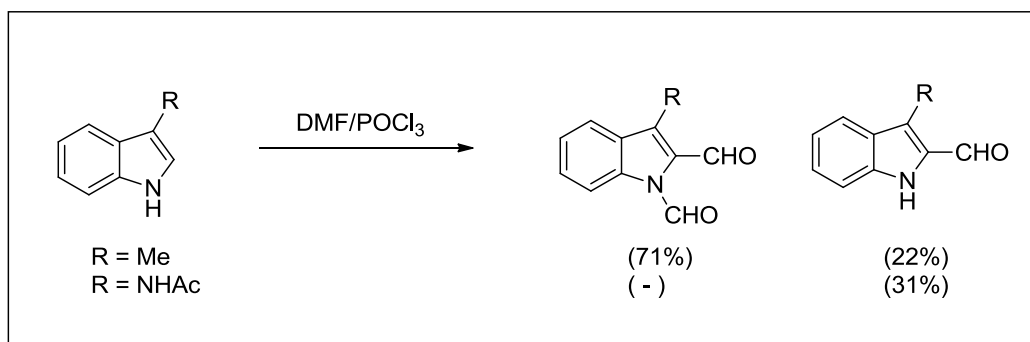





Scheme 43 Vilsmeier formylation of 3-substituted indoles.⁷⁸

2.0.4. Aliphatic substrates

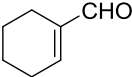
The extension of the Vilsmeier-Haack formylation to aliphatic compounds has been well reviewed by Jones and Stanforth.^{78,79} A range of aliphatic compounds have been successfully formylated by Vilsmeier reagents, as shown in Table 12. The Vilsmeier formylation of ketones and silyl enolates will be discussed separately.

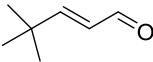
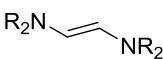
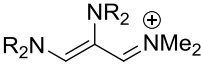
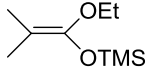
Table 12 The Vilsmeier formylation of various aliphatic compounds.

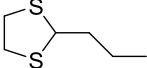
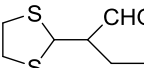
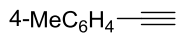
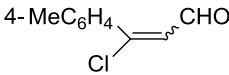
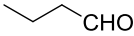
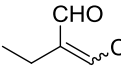
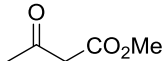
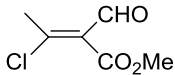
entry	substrate	reagent	product	yield	ref.
1.		NFM / POCl ₃		35	80
2.		NFM / POCl ₃		80	80
3.		DMF / COCl ₂		99	79
4.		DMF / POCl ₃		52	81
5.		1. DMF / COCl ₂		77	82
6.		<i>N</i> -methyl morpholine / POCl ₃		70	78
7.		DMF / POCl ₃		40	79
8.		DMF / POCl ₃		56	83

Two important factors in the reactions of alkenes with chloroiminium salts are the energy of the highest occupied molecular orbital (HOMO) of the substrate and the stability of the carbocation intermediate formed after attack by the chloroiminium salt.⁷⁸ Because the Vilsmeier salt is a weak electrophile,⁸⁴ the alkene usually needs to be in an activated form. Dienes and polyenes derive their activation from the raised energy of the HOMO due to the conjugation of the double bonds.⁷⁸ Nevertheless, it has been reported that unactivated alkenes, such as cyclohexene and 3,3-dimethylbut-1-ene have been formylated by the iminium salt derived from *N*-formylmorpholine and POCl₃, to give α,β -unsaturated aldehydes (entries 1 and

2 in Table 12), an important class of organic compounds.^{79,80} Styrenes react with DMF/(COCl)₂ to form the relatively stable carbocation intermediate **113** where the positive charge is stabilised by the presence of the aromatic ring. Deprotonation of this intermediate followed by hydrolysis gives a cinnamaldehyde **114** (Scheme 44).^{78,79}

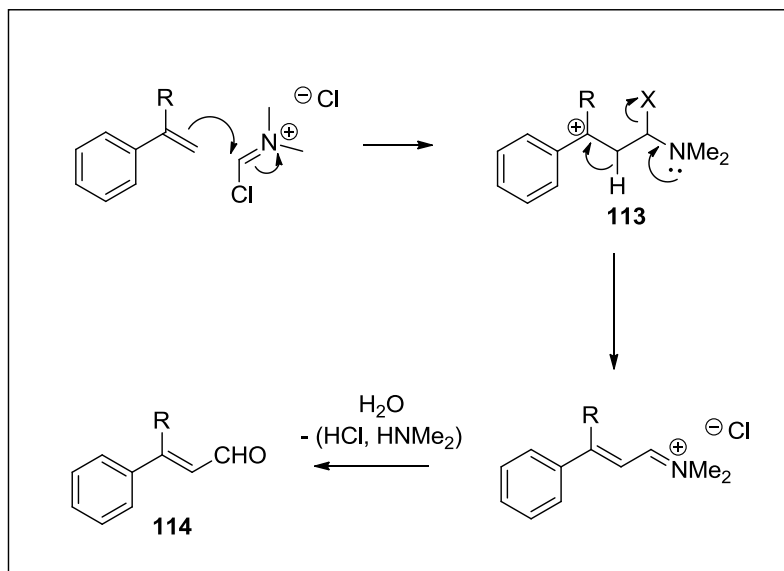

Scheme 44 Vilsmeier formylation of styrenes.⁸⁴

As illustrated in the scheme above, the reaction of an alkene with a Vilsmeier reagent involves the formation of a carbocation intermediate. In aliphatic alkenes, only substrates in which one of the double bonds is attached to two alkyl substituents react, evidently because only these compounds can form stable carbocations.⁷⁸ The carbocation has a short lifetime and double bond migration can occur before or after its formation.⁷⁸ In substrates which contain both an alkene functional group and an aromatic ring, the site of formylation can depend on the reaction conditions employed.^{78,85} Simple aliphatic dienes are unreactive, but dienes constrained in a ring system, such as in steroid **115**, react with DMF/POCl₃ at room temperature, to give an α,β -unsaturated aldehyde. At high temperature formylation occurs with loss of the acetic acid group by elimination (Scheme 45).^{78,86}

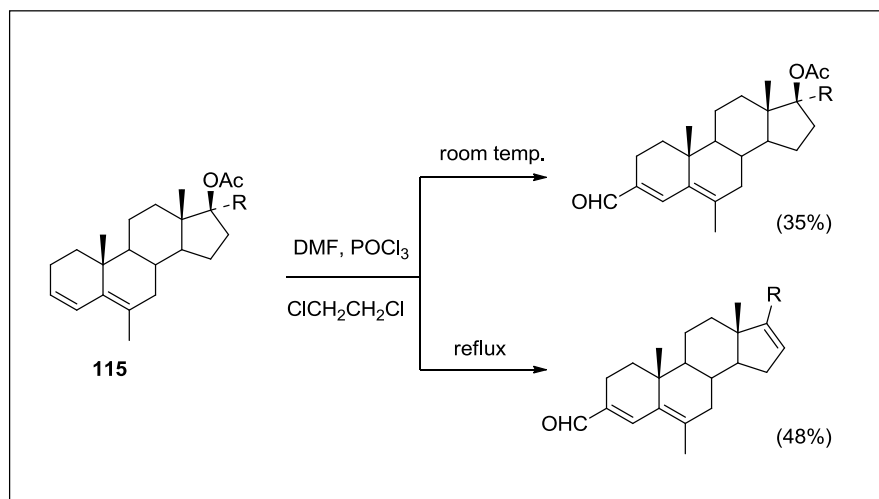

Scheme 45 Vilsmeier formylation of a diene constrained in a ring system.⁷⁸

Trienes, such as 3,7-dimethyl-2,4,6-octatriene **116**, react with Vilsmeier reagent to give a monoformylated product **117** at the 1-position, as a mixture of *Z/E* and *E/E* isomers (Scheme 46).⁸⁷

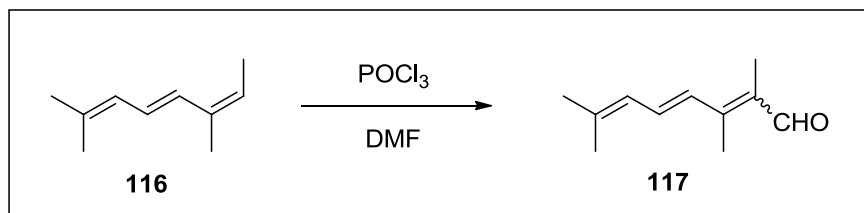

Scheme 46

Polymethines are a class of compounds which, like aromatic substrates, have delocalized π electrons and they react with chloroiminium salts to give polymethinium salts.⁷⁹ Merocyanine **118** reacts with DMF/ COCl_2 to give intermediate **119** which is hydrolysed to give triformylmethane **120** (Scheme 47).⁷⁹

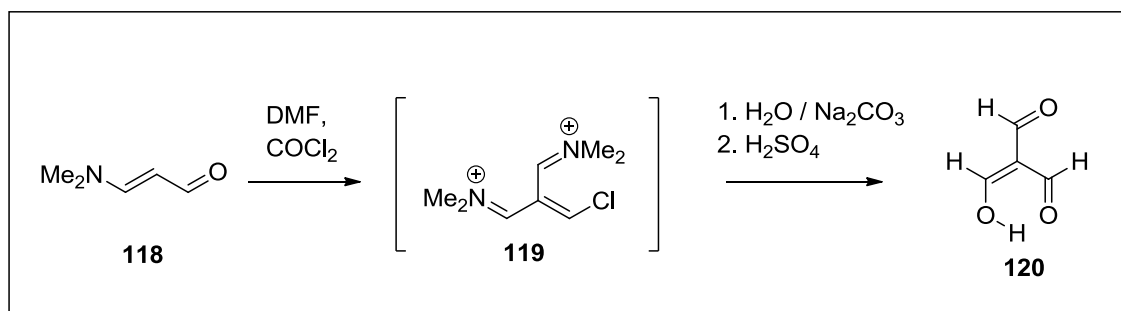

Scheme 47 Vilsmeier formylation of polymethine **118**.⁷⁹

2-Substituted malonaldehydes **121** have been prepared from carboxylic acids of the type R-CH₂-CO₂H **121** (where R = aryl, heteroaryl, CO₂Et, Cl, etc.).⁷⁹ The carboxylic acid reacts with DMF/POCl₃ to give a 3-(dimethylamino)acrolein **123** (via intermediate **122**), which undergoes hydrolysis to give the malonaldehyde **124**.⁷⁹ Fluoromalonaldehydes can be prepared in the same way (where R=F, Scheme 48) by the reaction of the sodium salt of fluoroacetic acid with DMF/POCl₃ in the presence of triethylamine. Fluoromalonaldehyde is an important precursor to several fluoro-substituted carbocycles and heterocarbocycles.⁷⁹

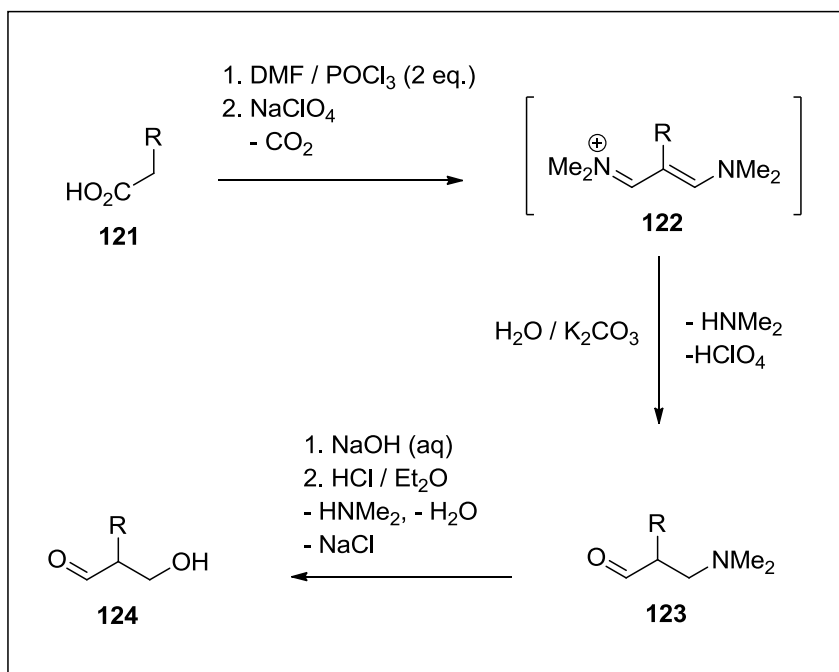

Scheme 48 Vilsmeier formylation of 2-substituted malonaldehydes.⁷⁹

α -Enamino esters **125**, derived from aldehydes and *N,N*-dimethylglycine ethylester, react with DMF/(COCl)₂ under mild conditions, to give carbethoxy-substituted vinamidinium salts **126**.⁸⁸ These materials are difficult to isolate, but react with hydrazine hydrate to give substituted pyrazoles **127** (Scheme 49).⁸⁸

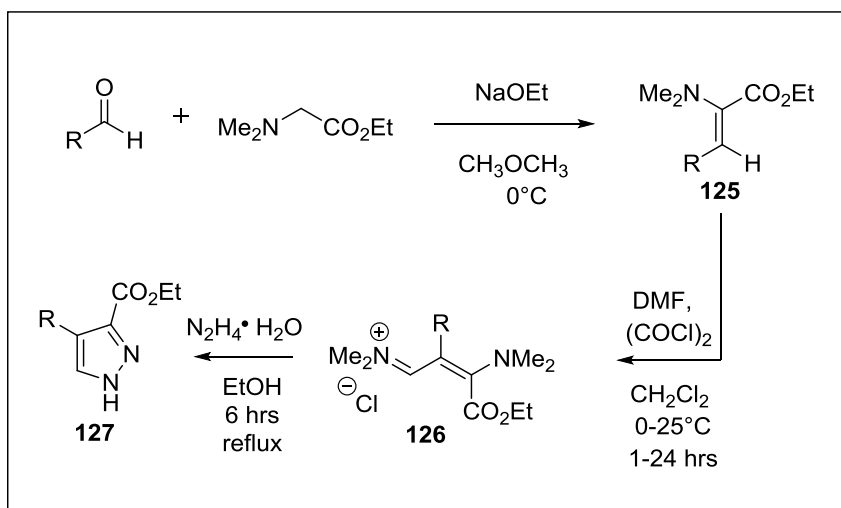

Scheme 49 Vilsmeier formylation of α -enamino esters.⁸⁸

Enamines and enol ethers can be described as activated alkenes in which the electron donating heteroatom raises the energy of the HOMO of the alkene functional group.^{78,79} Cyclic enamines **128** derived from morpholine, have been reacted with DMF/(COCl)₂ to give intermediates, which after hydrolysis, give unstable β -ketoaldehydes, which tautomerise to α -hydroxymethylene ketones **129** (Table 13).⁸⁹

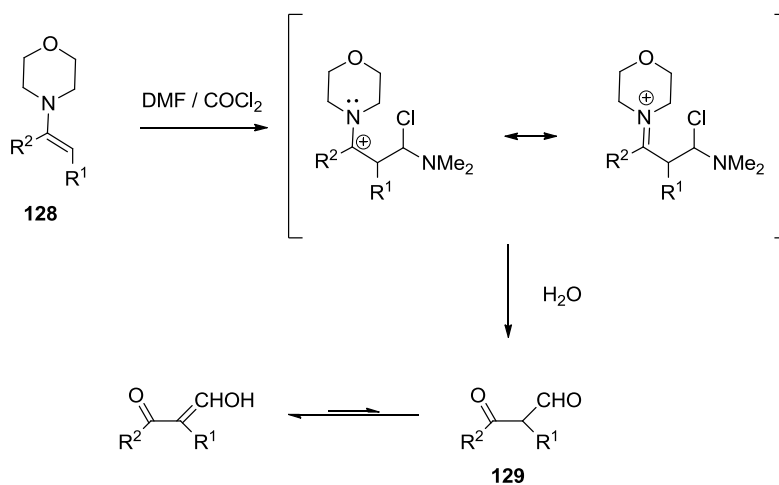

Scheme 50 Vilsmeier formylation of morpholine derived enamines.⁸⁹

Table 13 Vilsmeier formylation of morpholine derived enamines.⁸⁹

R ² -C=C-R ¹	yield (%) ^(a)	boiling point (°C/ mm) or melting point (°C)
cyclopentenyl	ca. 20	71-72
cyclohexenyl	52 ^(b)	40-42 / 1
cycloheptenyl	48	58-60 / 1.5
3,4-dihydronaphthyl	92	123-125 / 2
cyclodocenyl	59	115 – 116 / 1

^[a] based on enamine ^[b] with 1-piperidinocyclohexene, the yield is 50%

2.0.5 Formylation of *O*-silylated enolates

Silyl enol ethers are less reactive nucleophiles than enamines, and one consequence of this is that the product mixtures they give after Vilsmeier formylation are less complicated.⁷⁸ Reddy and Tanimoto have reacted silyl ketene acetals **130** with DMF/POCl₃ at room temperature to give α -formyl esters **131** in reasonable yield (Table 14).⁸¹ The trimethylsilylenol ether of cyclohexanone **132** reacted with DMF/POCl₃ to give 2-chloro-1-formylcyclohexanone **133** rather than the expected 2-(hydroxymethylene)-cyclohexanone (Scheme 51).⁸¹

**Scheme 51** Vilsmeier formylation of silyl ketene acetals and the formylation of silyl enol ether.⁸¹

Table 14 Vilsmeier formylation of silyl ketene acetals.⁸¹

130, 131	R ¹	R ²	R ³
a	H	C ₂ H ₅	C ₂ H ₅
b	CH ₃	CH ₃	C ₂ H ₅
c	CH ₃	C ₂ H ₅	CH ₃
d	H	<i>i</i> -C ₃ H ₇	C ₂ H ₅
e	C ₂ H ₅	C ₂ H ₅	C ₂ H ₅
f	—(CH ₂) ₄ —		CH ₃
g	—(CH ₂) ₅ —		CH ₃

Jameleddine and co-workers have reported the formylation of *O*-silylated enolates (Table 15).⁹⁰ Interestingly, they report that the product of the reaction of silyl enol ether **132** with DMF/POCl₃ is the α -hydroxymethylene ketone **134** and not the chloroenal **133** as reported by Reddy and Tanimoto who did the same reaction, and the mass spectral and elemental analysis data that former authors have reported indicates that this is correct (Scheme 52).⁹⁰

**Scheme 52**

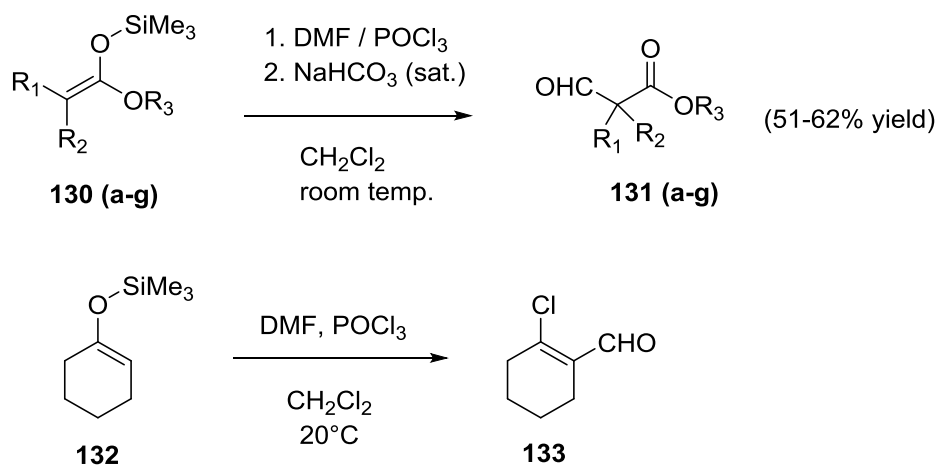
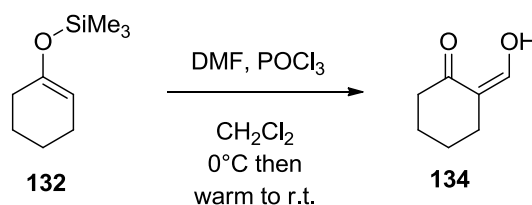
It may be that the product obtained is sensitive to the exact reaction conditions employed. Jameleddine and co-workers reacted various silyl enol ethers, including **132**, with DMF/POCl₃ (2 eq.), in dichloromethane, at 0°C for 90 mins under nitrogen, and then allowed the solutions to warm to room temperature, followed by work up with aqueous base (NaOH), to give the α -hydroxymethyleneketones.⁹⁰ The researchers who reported the chloroenal as the product used a procedure that was similar. The silyl enol ether was added to a solution of DMF/POCl₃ (1 eq.) at 0-10 °C, in dichloromethane under nitrogen, and the solution was then stirred at room temperature for 15 hrs, followed by work up with aqueous base (NaHCO₃) to give the chloroenal. The products isolated by Jameleddine and co-workers are shown in Table 15.⁹⁰

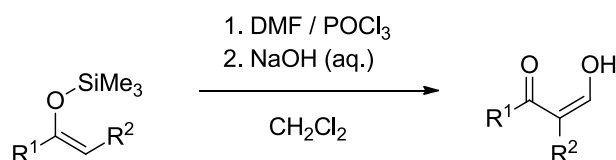

Scheme 53 Vilsmeier formylation of silyl enol ethers.⁹⁰

Table 15 Vilsmeier formylation of silyl enol ethers.⁹⁰

entry	substrate	product	% yield
1			78
2			81
3			45
4			76
5			54

2.0.6 Formylation of aldehydes and ketones

There are few reported reactions of aldehydes with Vilsmeier reagents. Butanal reacts with DMF/ POCl_3 to give the corresponding choroenal **135**.⁷⁸ Conjugated aldehydes, such **136**, react to give chloroiminium salts, which when reacted with an amine, such as aniline, give the stable ammonium salt **137** which is more easier to handle (Scheme 54).⁷⁸

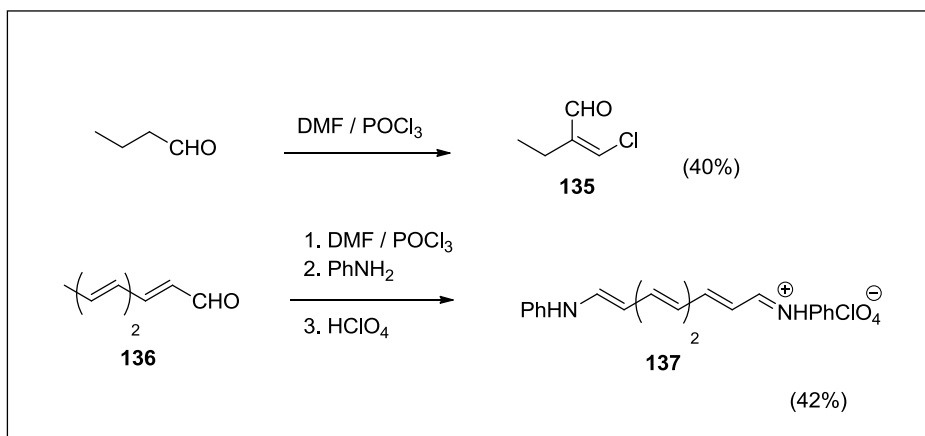

Scheme 54 Vilsmeier formylation of aldehydes.⁷⁸



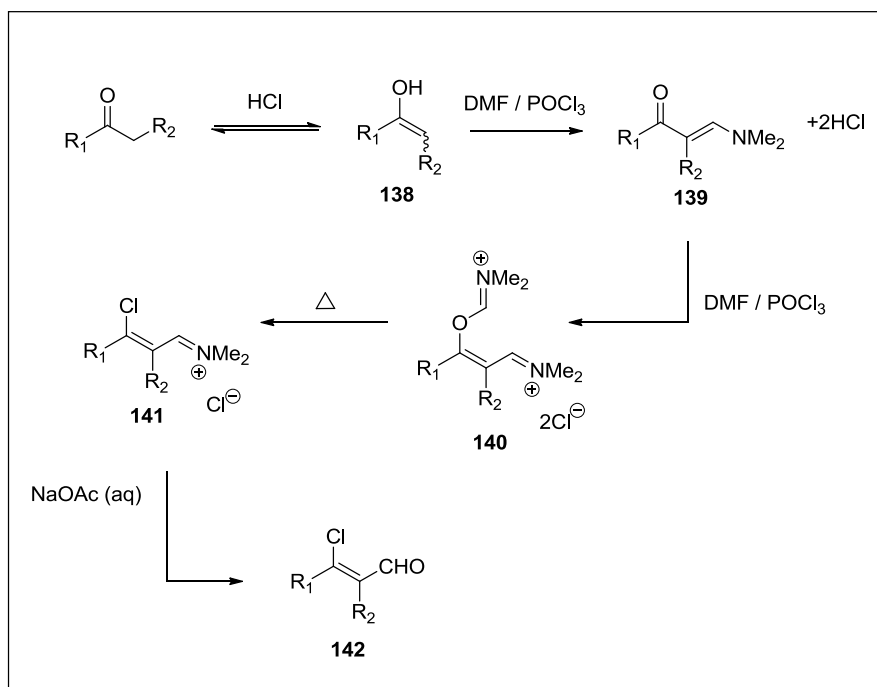

The reactions of ketones with Vilsmeier reagents have been well reviewed by C.M. Marson.^{91,92} It is suggested that ketones tautomerise, in the presence of H^+ , to form an enol **138**, which reacts as a nucleophile and attacks Vilsmeier salts to form intermediates **139-141** the last of which undergoes hydrolysis to give a formylated product **142** (Scheme 55).⁹¹

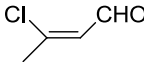

Scheme 55 Vilsmeier formylation of ketones.⁹¹

The table belows shows the major products obtained from the formylation of a range of ketones (Table 16).

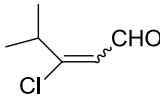
Table 16 The Vilsmeier formylation of various ketones.

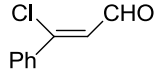
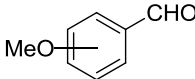
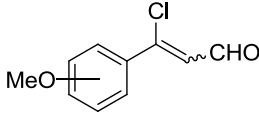
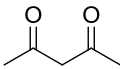
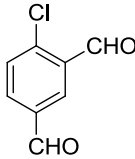
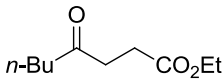
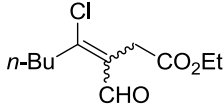
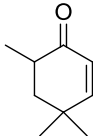
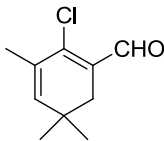
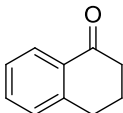
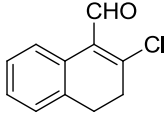
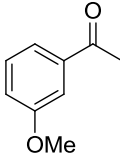
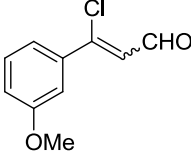
entry	substrate	reagent	product	yield	ref.
1.		DMF / POCl ₃		39	91
2.		DMF / POCl ₃		14	78
3.		DMF / COCl ₂		54	93
4.		DMF / COCl ₂		3-MeO (71%) 4-MeO (70%)	94
5.		DMF / POCl ₃		98	78
6.		DMF / POCl ₃		53	78
7.		DMF / POCl ₃		90	95
8.		DMF / POCl ₃		56	91
9.		DMF / POCl ₃		71	96

Simple acyclic ketones react with chloroiminium salts to form β -chloroenals.⁹¹ Formylation occurs at the more substituted carbon, but bulky substituents such as the isopropyl group can block reaction at this site, in which case formylation takes place at the less substituted carbon (Scheme 56).⁹¹

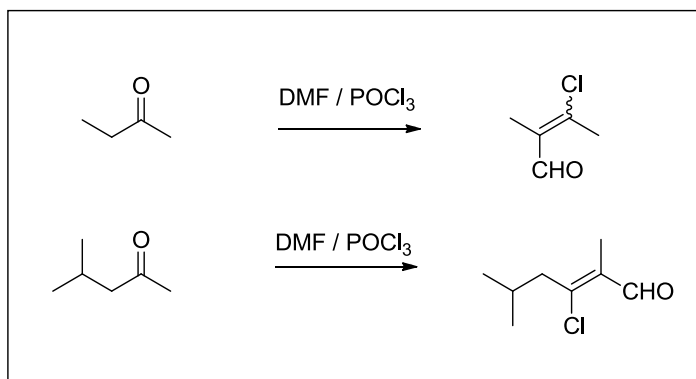

Scheme 56 The Vilsmeier formylation of acyclic ketones.⁹¹

α,β -Unsaturated aldehydes can be prepared by reacting a ketone with DMF/ POCl_3 to give a chloroenal, which is then selectively dehalogenated by catalytic hydrogenolysis to afford the desired α,β -unsaturated aldehyde **143**.^{95,97} The products obtained using this method were found to be contaminated with small amounts of the saturated analogues. Reaction of the chloroenals with hydroxylamine, followed by dehydration with triphenylphosphine, gave β -chloro- α,β -unsaturated nitriles in 80-90% yield, which were reduced by catalytic hydrogenolysis to an α,β -unsaturated nitrile **144** (Scheme 57).⁹⁵

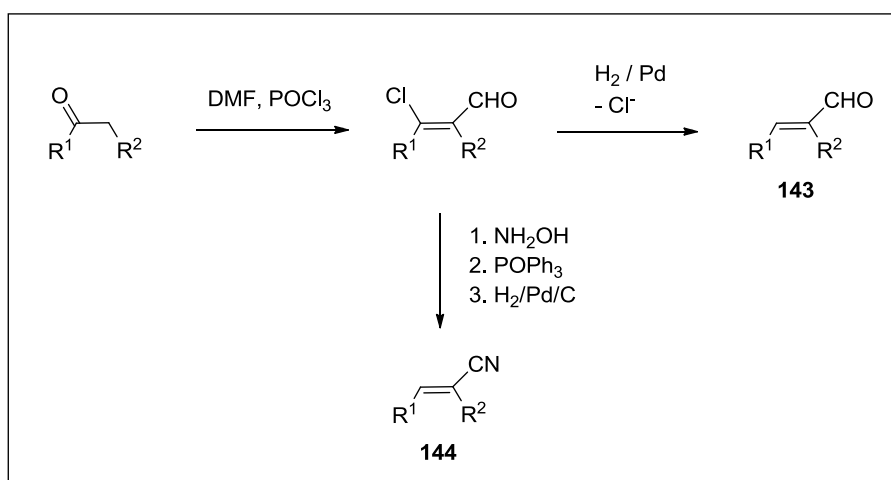

Scheme 57

Monocarboxylic ketones react with DMF/POCl₃ to give β-chlorovinyl aldehydes.⁹¹ 3-Methyl cycloalkanones undergo formylation mostly at the less sterically hindered α-position.⁹⁸ Surprisingly, researchers found that the selectivity increases with ring size, even though the larger rings possess greater flexibility and it was expected that steric hindrance would be less of a factor with increasing ring size (Scheme 58).⁹⁸

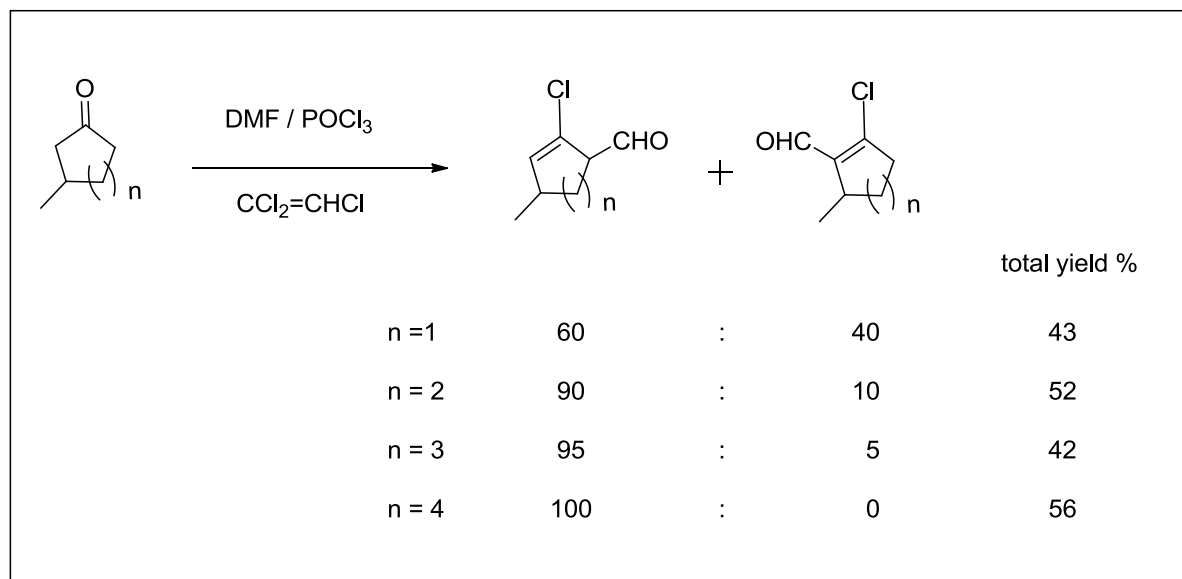

Scheme 58 The effect of ring size on the position of formylation of 3-methyl cycloalkanones.⁹⁸

Steroidal α,β-unsaturated ketones react with Vilsmeier reagent to give the chlorodiene as the major product.⁹¹ However, reaction of 19-nortesterone acetate **145** with DMF/POCl₃, followed by work up with aqueous sodium acetate, gave a mixture of **147** and **148** in equal amounts as well as the chlorodiene **146** (Scheme 59).^{91,99}

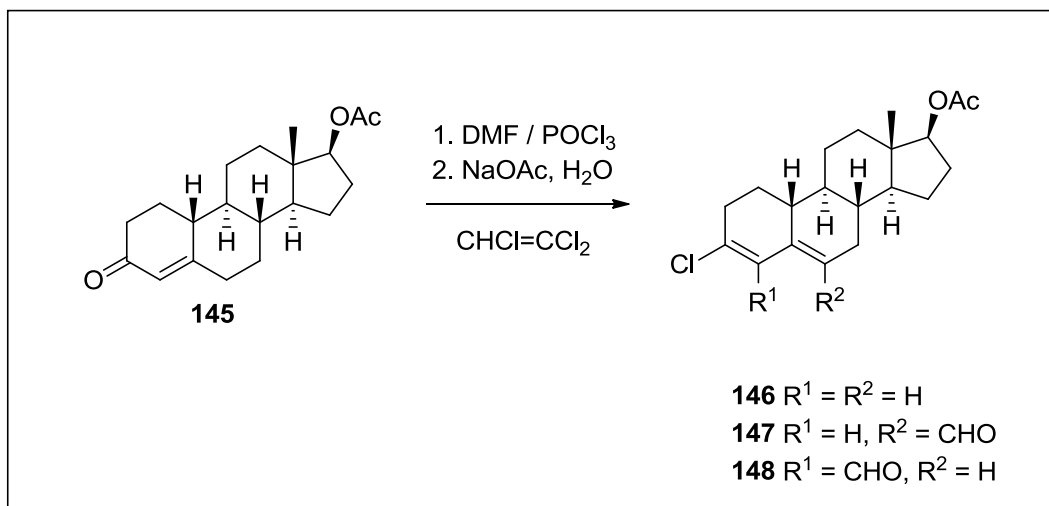

Scheme 59 The Vilsmeier formylation of a steroidal α,β -unsaturated ketone.⁹⁹

Chapter 2

Statement of aims

The aim of this project was to devise a new method for the asymmetric α -formylation of enol substrates (initially silyl enol ethers), built on the Vilsmeier-Haack protocol, using chiral chloroiminium salts derived from (*S*)-proline.

Chapter 2 α -Formylations of α -substituted ketones

2.1 Introduction

Jameleddine and co-workers have demonstrated that silyl enol ethers can be formylated by the Vilsmeier reagent at the α -position to give α -formylated ketones,⁹⁰ and Scolastico and co-workers have reported the asymmetric α -formylation of silyl enol ethers and enamines (of ketones), using nor-ephedrine derived orthoamides as chiral auxiliaries.⁵⁵ The chloroiminium derived from DMF/ $(\text{COCl})_2$ is achiral and therefore a prochiral silyl enol ether which has been formylated by that reagent will give a product that is a racemic mixture of two enantiomers. This is because attack by the silyl enol ether on the chloroiminium salt is equally likely at either face. Subsequent hydrolysis then gives the product as a 50:50 mixture of the two enantiomers (Scheme 60).

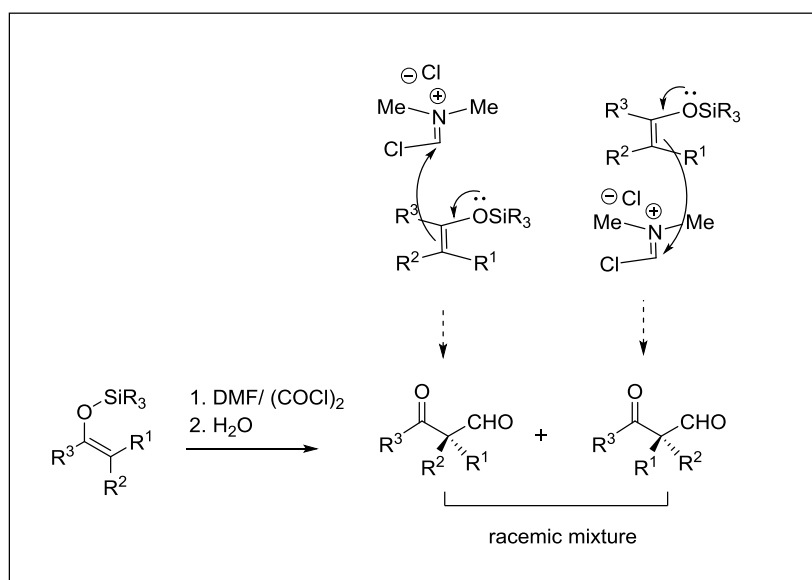

Scheme 60

It was hypothesized that a chiral chloroiminium salt might afford an environment in which there would be a certain amount of facial discrimination in this key step. The research described in this thesis was directed towards the asymmetric α -formylation of enol substrates (initially silyl enol ethers) using chiral chloroiminium salts derived from (*S*)-proline.

It was predicted that a chiral formamide, such as *N*-formyl-(*S*)-proline methyl ester **149** would react with $(\text{COCl})_2$ to give the corresponding Vilsmeier reagent **150**, and that reaction of a pro-chiral silyl enol ether with this iminium salt, followed by hydrolytic work up, would give a non-racemic product. This prediction was based on the premise that the presence of a sterically large group projecting out of one face of the chloroiminium salt is likely to hinder attack by the enol at this face. If so, this was predicted to increase the chance some of facial selectivity in the attack by a pro-chiral silyl enol ether on the iminium salt **150**, as shown in Scheme 61, to give α -formyl ketone **151** and this model will be discussed in more detail in the next chapter. In Scheme 61 the cyclic backbone of the chloroiminium salt has been depicted as planar for clarity.

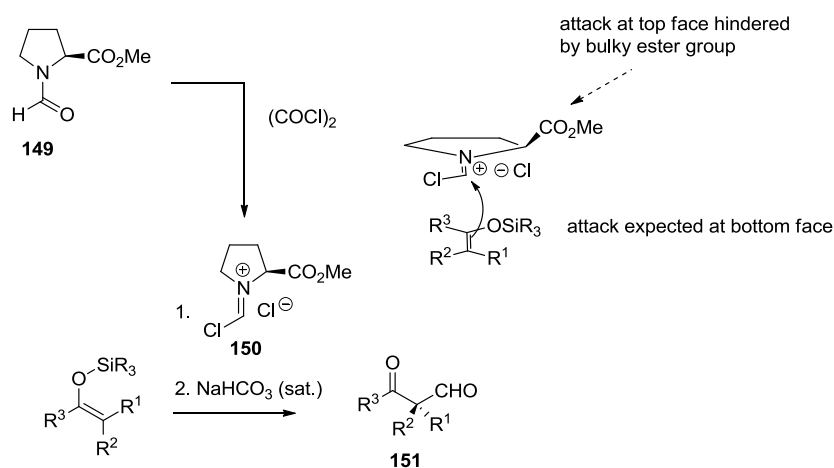

Scheme 61 Proposed asymmetric Vilsmeier formylation of silyl enol ethers.

The preparation of *N*-formyl-(*S*)-proline methyl ester from (*S*)-proline is given in the next chapter, which describes the asymmetric extension of the Vilsmeier reaction using chiral chloroiminium salts. The first substrate to be used in this reaction was the trimethylsilyl enol ether of cyclohexanone and its preparation is described below.

2.2 Preparation of cyclohexen-1-yloxy(trimethyl)silane **152**

Cyclohexanone was dissolved in DMF and to the solution was added triethylamine and trimethylsilylchloride under an argon atmosphere, and the solution heated at reflux for 24 hours, followed by hydrolytic work up. The crude material was distilled at low pressure, using

a Kugelrohr apparatus, to give the product **152** as a colourless oil (6 % isolated yield). The low yield was probably due to a combination of low percentage conversion and significant hydrolysis of the silyl enol ether product during aqueous work up.

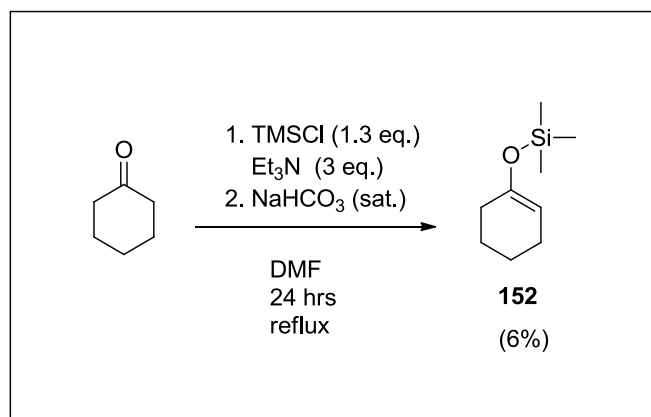

Scheme 62 Preparation of cyclohexen-1-yloxy(trimethyl)silane.¹⁰⁰

Having prepared the silyl enol ether the next step was to react it with the chloroiminium salt **150** to ascertain whether a formylated product could be isolated after hydrolytic work up. The reaction was conducted as described below:

2.3 α -Formylation of silyl enol ethers **152**, **154** and **158**

N-Formyl-(*S*)-proline methyl ester **149** was dissolved in dry dichloromethane and the solution cooled to 0°C followed by the addition 1 equivalent of (COCl)₂, and the reaction mixture stirred, under argon for 1 hour, during which time the solution turned yellow. Then 1 equivalent of the silyl enol ether **152** was added and the reaction mixture stirred at room temperature for 24 hours, followed by work up with aqueous base (NaHCO₃), to afford the crude material, which was analysed by ¹H NMR spectroscopy. The spectral data obtained indicated that product **153** was an enol, as shown below, and this data will be discussed later in this chapter (Scheme 63).

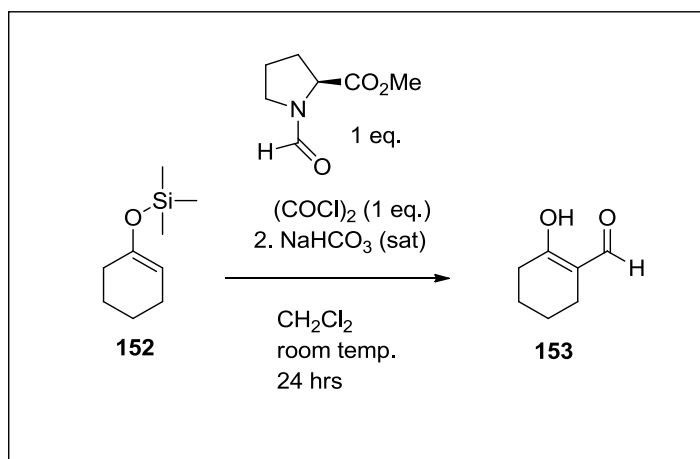

Scheme 63 Vilsmeier formylation of cyclohexen-1-yloxy(trimethyl)silane.

Importantly, the ^1H NMR spectrum of the crude material showed a singlet at δ 9.7 ppm which is characteristic of an aldehyde proton. This indicated that an α -formyl product was present in the crude mixture, *i.e.* that formylation had been achieved, with a percentage conversion of approximately 40%. The reaction was repeated with 3 equivalents of the same chloroiminium salt **150**, with a view to increasing the percentage conversion, with the other reaction parameters kept constant, and analysis of the crude mixture obtained after the reaction indicated that the percentage conversion had increased to 46%.

The initial experiment had demonstrated that cyclohexen-1-yloxy(trimethyl)silane **152** had been successfully formylated by the chiral chloroiminium salt **150**. It was then necessary to vary some of the reaction parameters, with a view to optimizing the reaction conditions for this formylation. Formamide **149** was only available in relatively small quantity and in any event the product enol **153** is achiral (making the use of a chiral chloroiminium salt immaterial), so it was deemed experimentally wise to use the chloroiminium salt derived from DMF/ $(\text{COCl})_2$ to find the optimum conditions for the reaction, since both reagents were available in the laboratory. This was based on a working assumption that the optimum conditions for a formylation using DMF/ $(\text{COCl})_2$ (*i.e.* the number of equivalents of Vilsmeier reagent, temperature, reaction time etc.) could be used to give some indication as to what the best conditions might be for subsequent asymmetric formylation of other substrates (whose products do not enolise) using the chiral Vilsmeier salt **150** and other chiral iminium salts.

The formylation of cyclohexen-1-yloxy(trimethyl)silane **152** was repeated using the same method and reaction conditions, except that DMF was used instead of *N*-formyl-(*S*)-proline methyl ester **149**. Analysis of the crude mixture indicated that formylation had occurred, with

a percentage conversion of 36%. The crude material from the above experiment was purified by column chromatography, with hexane / ethyl acetate (10:1), to give the pure product **153** as a colourless oil (11% isolated yield).

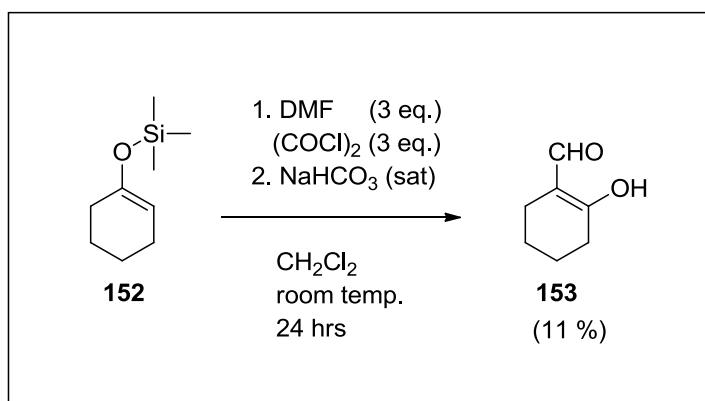

Scheme 64 Vilsmeier formylation of cyclohexen-1-yloxy(trimethyl)silane.

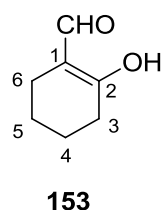
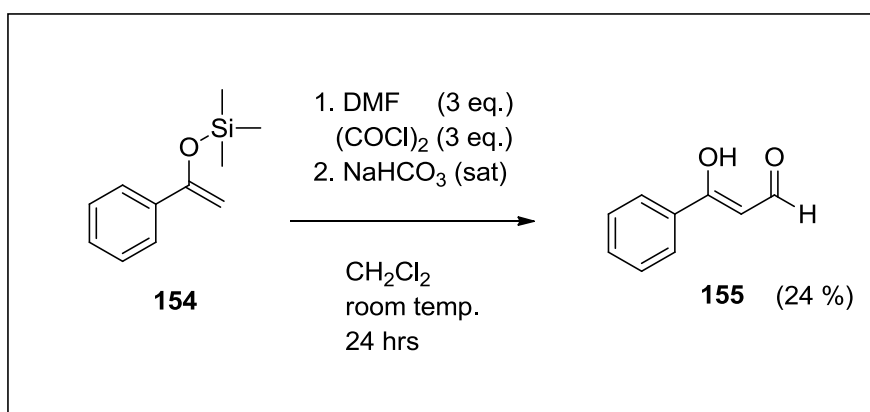

Figure 4

¹H NMR analysis of product **153** gave a 4H multiplet at δ 1.58-1.79 ppm corresponding to the two sets of CH₂ protons attached to the carbons at positions 4 and 5 (Figure 4), a 2H multiplet at δ 2.19-2.30 ppm corresponding to the CH₂ protons at position 3 and a 2H multiplet at δ 2.48-2.59 ppm corresponding to the CH₂ protons at position 6. The aldehyde proton appeared as a 1H singlet at δ 10.15 ppm, and the OH proton appeared as a broad 1H singlet at δ 1.21 ppm. This spectral data was consistent with the assigned structure shown above.

The trimethyl silyl enol ether of acetophenone **154** (prepared using the same method as for the preparation of silyl enol ether **152**) was also tested as a substrate for this transformation. It was reacted with 3 equivalents of DMF/(COCl)₂ in dichloromethane, at room temperature for 24

hours, using the same method and work up procedure described for the formylation of silyl enol ether **152**. This method will henceforth be referred to as the standard formylation procedure. Column chromatography (SiO₂) with hexane / ethyl acetate (20:1) afforded the product **155** as a yellow oil (24 % isolated yield).



Scheme 65 Vilsmeier formylation of trimethyl(1-phenylvinyl)oxy silane.

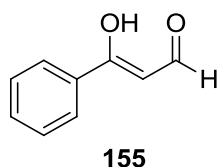
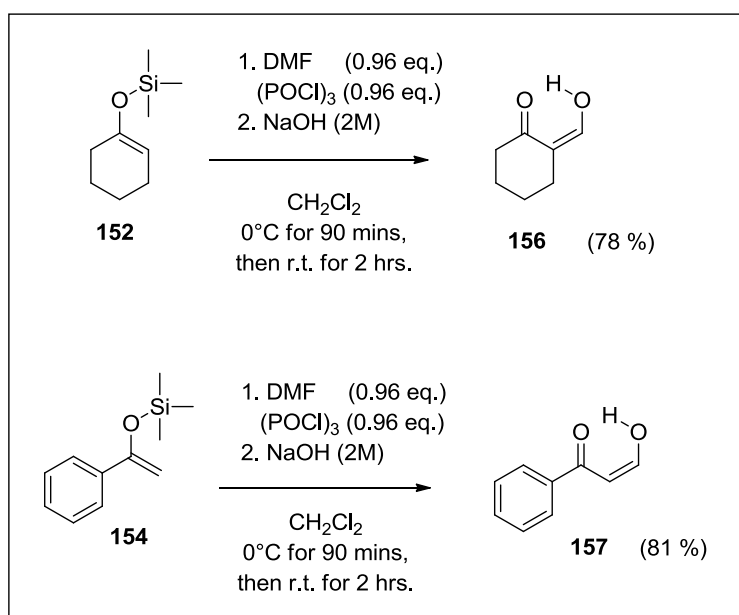

Figure 5

¹H NMR analysis of product **155** gave a 1H doublet at δ 6.64 ppm, J = 8 Hz corresponding to the vinyl proton, a 3H multiplet at δ 7.36-7.55 ppm and 2H multiplet at δ 7.65-7.79 ppm, both corresponding to the aromatic protons, and a 1H doublet at δ 10.19 ppm, J = 8 Hz, corresponding to the aldehyde proton. The aldehyde proton is coupled to the vinyl proton hence the signals for both these protons appear as doublets with a coupling constant of 8 Hz. This data was in agreement with the structure shown above.

Interestingly, the NMR data that was obtained for the products of the formylations of silyl enol ethers **152** and **154** differed significantly from that reported by Jameleddine and co-workers in the literature.⁹⁰ They formylated the same substrates using the chloroiminium salt derived from DMF/ POCl_3 in an otherwise similar method which was as follows: a stirred solution of POCl_3 in dichloromethane was cooled to 0°C and to the solution was added a solution of DMF (1 eq.) in dichloromethane, and the mixture stirred for 30 mins under nitrogen. Then the silyl enol ether (0.96 eq.) was added at 0°C and after 90 mins the reaction mixture was allowed to warm to room temperature and stirred for a further 2 hrs. The reaction was then quenched by the addition of 2M sodium hydroxide and extracted with brine, dried over magnesium sulfate, filtered, and the residue purified by column chromatography (SiO_2 , hexane / diethyl ether 8:1) to give the formylated product. In the ^1H NMR data for the formylation product of silyl enol ether **152** they report a 4H multiplet at δ 1.7-1.4 ppm, a 4H multiplet at δ 2.2-2.4 ppm, a 1H singlet at δ 6.0 ppm and a 1H singlet at δ 15.4 ppm.⁹⁰

In their ^1H NMR data for the formylation product of silyl enol ether **154**, they report a 1H doublet at δ 5.8 ppm, $J = 8.9$ Hz, a 1H doublet at δ 6.8 ppm, $J = 8.9$ Hz, a 3H multiplet at δ 7.5-7.2 ppm, a 2H multiplet at δ 7.9-7.6 ppm, and a 1H singlet at δ 15.3 ppm. Based on this data they assigned the structures shown below to the compounds they isolated (Scheme 66).⁹⁰ Evidently compounds **156** and **157** can tautomerise easily, and it may be that the actual compound isolated depends on the exact reaction and work up conditions employed.



Scheme 66 Vilsmeier formylation products reported by Jameleddine and co-workers.⁹⁰

α -Formylation of the trimethylsilyl enol ether of 1-indanone **158** gave product **159** which largely decarbonylated on the silica column during chromatography, though enough of it was isolated to obtain a ^1H NMR spectrum.

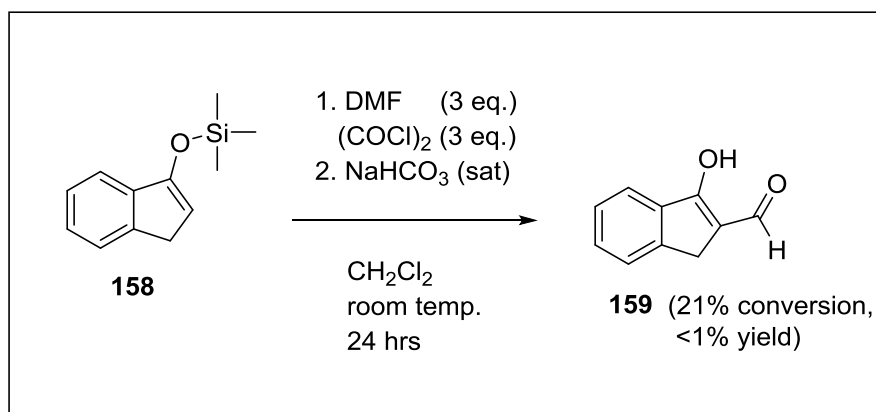

Scheme 67 Vilsmeier formylation of (1*H*-inden-3-yloxy)(trimethyl)silane.

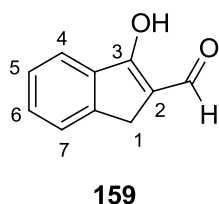

Figure 6

The ^1H NMR data obtained for product **159** gave a broad 1H singlet at δ 1.19 ppm corresponding to the OH proton, a 2H singlet at δ 3.63 ppm corresponding to the CH₂ protons at position 1, a 3H multiplet at δ 7.38-7.51 ppm corresponding to the aromatic protons at positions 5, 6 and 7, and a 1H doublet at δ 7.64, $J = 8$ Hz, corresponding to the aromatic proton at position 4. The aldehyde proton appeared as a 1H singlet at 10.18 ppm. This data was consistent with the structure shown in Figure 6, though literature data for product **159** was not found. However, α -formyl indanone is a known compound, and it may be that tautomerisation of the formylated material during the work up procedure led to the isolation of product **159**, instead of α -formyl indanone (the expected product).

2.4 Preparation of 2-methyl-1-indanone and 2-methyl-1-tetralone.

It was deemed desirable to prepare silyl enol ethers which had an alkyl group at the α position to the carbonyl group. This would rule out the possibility of the molecule tautomerising to give the unsaturated compounds observed so far.

Compound **160**, 2-methyl-1-indanone, was prepared as follows: lithium diisopropylamide (LDA) was prepared *in situ* by adding *n*-butyllithium to a solution of diisopropylamine in tetrahydrofuran, under an argon atmosphere, at 0°C on an ice bath. The solution was stirred at this temperature for 10 mins and then cooled to -78°C. Then a solution of 1-indanone in tetrahydrofuran was added to the LDA solution, to generate the lithium enolate, followed by methylation of the enolate with methyl iodide. Aqueous work up followed by column chromatography of the crude material gave the product as a red oil (26% isolated yield, Scheme 68).

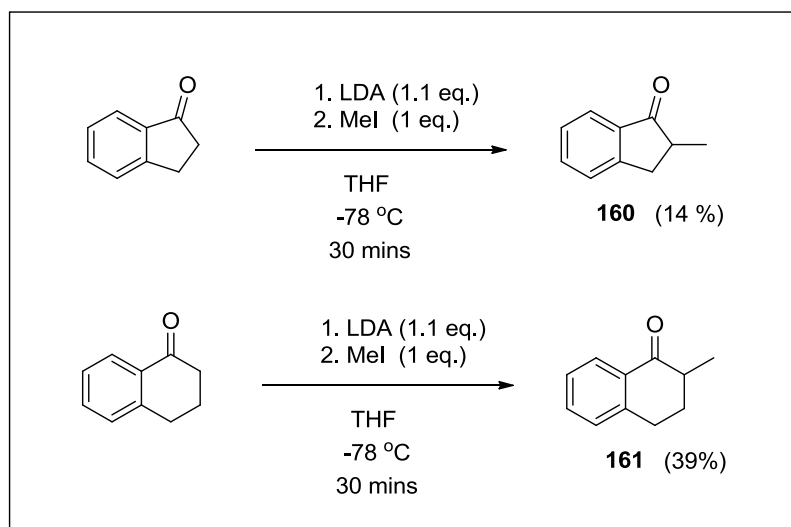

Scheme 68 Preparation of 2-methyl-1-indanone and 2-methyl-1-tetralone.¹⁰¹

Compound **161**, 2-methyl-1-tetralone, was prepared from 1-tetralone using the same procedure (Scheme 68). Column chromatography afforded the product as a purple oil (39% isolated yield). In both these methylation reactions, the crude mixtures contained significant amounts of dimethylated by-product. One possible explanation for this is as follows: once added to the LDA solution, the starting material undergoes deprotonation to form lithium enolate **163**,

which is methylated after the addition of methyl iodide. However, this mono-methylated compound **164** still contains an acidic proton, and can be deprotonated, either by remaining LDA in the solution, or perhaps by the lithium enolate itself, to form a second enolate **165**, which is methylated a second time, to form the dimethylated side product **166** (Scheme 69).

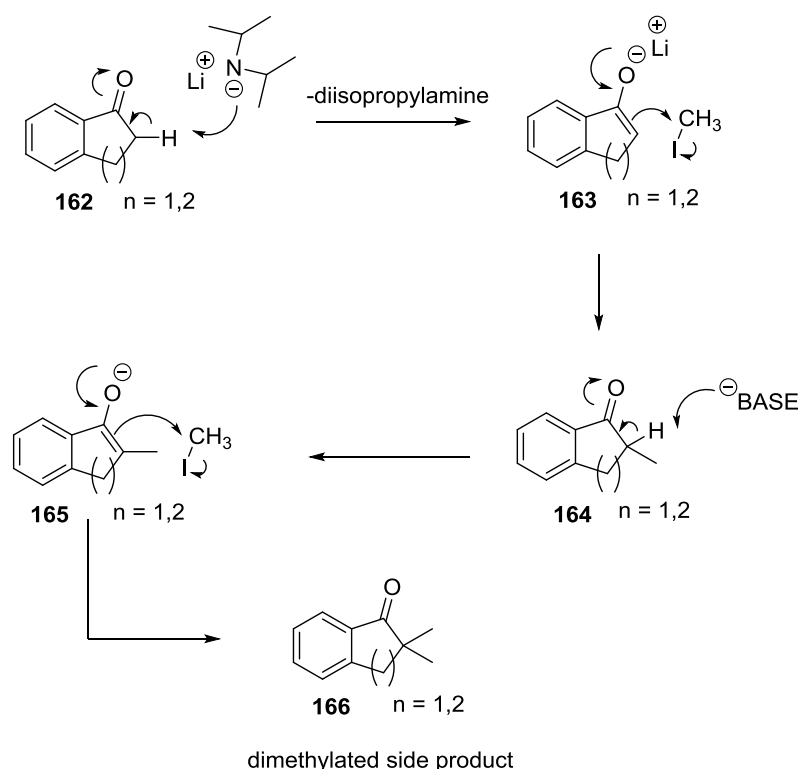

Scheme 69 Mechanism of the dimethylation of 1-indanone and 1-tetralone.

With a view to inhibiting this tendency, the experimental method was modified. The ketone was added to the LDA solution to form the lithium enolate as before. Then, a second flask was prepared containing 1 equivalent of methyl iodide in a solution of tetrahydrofuran. Then the first solution, containing the lithium enolate, was transferred dropwise by cannula to the flask containing the methyl iodide solution. It was reasoned that by adding the lithium enolate dropwise to a solution containing only methyl iodide (in THF), the lithium enolate would be present in an environment containing a large quantity of methyl iodide and a relatively small amount of base. Hence, once the lithium enolate was methylated a first time, there was little base present in the solution to allow it to re-form an enolate and methylate a second time. One practical drawback to this method (which was tested on α -tetralone) was the difficulty of

transferring the lithium enolate solution through the cannula. In any event, the crude mixture obtained using this method showed that a significant amount of dimethylation had occurred (37% of the crude product for the α -tetralone reaction). It was experimentally more convenient, in subsequent alkylations, to continue using the first method *i.e.* a slow, dropwise addition of the alkyl halide to the lithium enolate solution. It was found that as long as the addition was done slowly, (dropwise over a period of about 30 minutes) then dimethylation was minimised (19% of the crude product for the α -tetralone reaction, and 5% for the α -indanone reaction).

2.5 Preparation of trimethyl silyl enol ethers **167** and **168**

Trimethyl[(2-methyl-1*H*-inden-3-yl)oxy]silane **167** was prepared as follows: lithium diisopropylamide was prepared *in situ* by adding *n*-butyllithium to a solution of diisopropylamine in tetrahydrofuran and the solution cooled to -78°C . Then a solution of 1-indanone in tetrahydrofuran was added to the LDA solution followed by a dropwise addition of trimethyl silyl chloride and the mixture was allowed to warm to room temperature. Aqueous work up followed by column chromatography of the crude material afforded the product as a yellow oil (1.20g, 40 %).

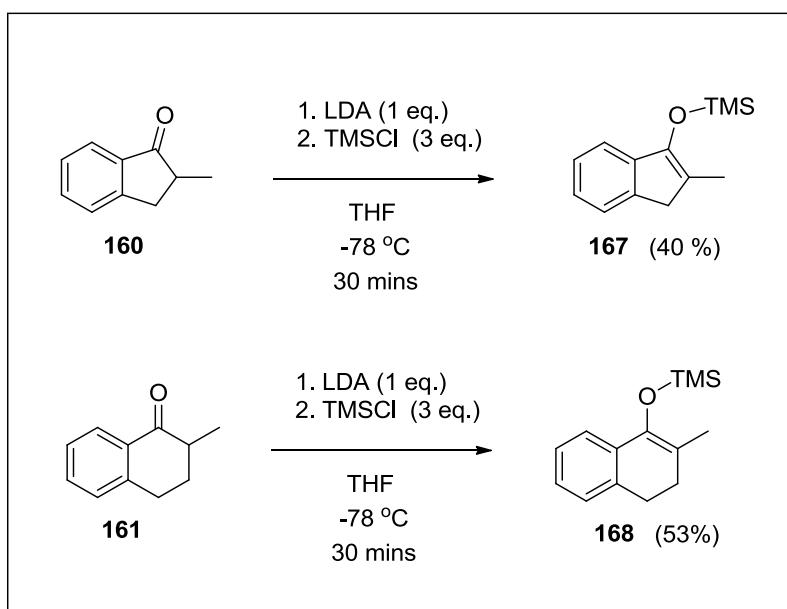

Scheme 70 Preparation of silyl enol ethers **167** and **168**.

Trimethyl[(2-methyl-3,4-dihydronaphthalen-1-yl)oxy]silane **168** was prepared from 2-methyl-1-tetralone using the same procedure. Column chromatography gave the product as a pale yellow oil (1.29g, 53 %). Both the trimethyl silyl enol ethers **167** and **168** reacted with DMF/(COCl)₂, under the standard conditions, to give α -formyl ketones after hydrolysis, however the products decarbonylated during column chromatography.

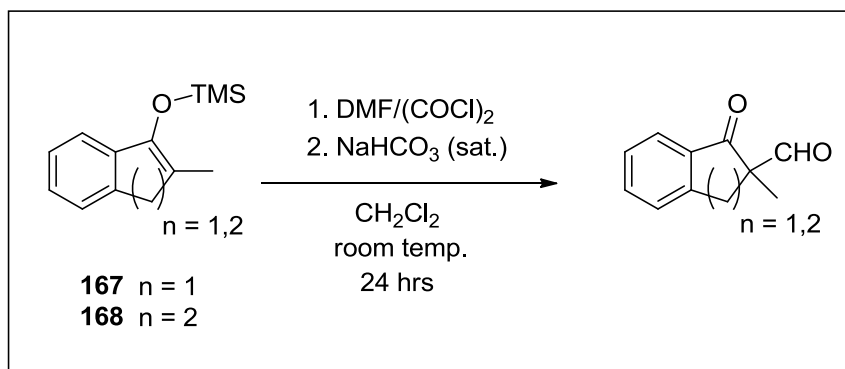

Scheme 71 α -Formylation of silyl enol ethers **167** and **168**.

Significantly, it was discovered that the ketones themselves react with DMF/(COCl)₂, to form α -formyl ketones after hydrolytic work up. The discovery was made inadvertently, where in one experiment instead of adding silyl enol ether **167** to a solution of DMF/(COCl)₂, 2-methyl-1-indanone **160** was added in error. After the standard aqueous work up, a crude ¹H NMR of the product indicated that the α -formyl ketone had been formed. This meant that it was not necessary to prepare a stabilised enolate of the ketone, such as the silyl enol ether, in order to make the substrate react. This was an important and useful development because it meant that a methodology had been discovered for the direct α -formylation of α -substituted ketones from the cheap and readily available starting materials DMF and oxalyl chloride, and such a transformation had not been reported in the literature.

2.6 α -Formylations of 2-methyl-1-indanone and 2-methyl-1-tetralone

The α -formylation of 2-methyl-1-indanone was conducted as follows: 2-methyl-1-indanone was reacted with 3 equivalents of DMF/(COCl)₂, in dichloromethane, at room temperature for 24 hours, followed by work up with aqueous base (NaHCO₃). ¹H NMR analysis of the crude mixture indicated that the percentage conversion was over 99%. However the material isolated after chromatography was nearly all starting material. Evidently, the α -formyl ketone had almost completely decarbonylated on the silica stationary phase. In order to circumvent this problem a modification was made in the work up procedure. Since the formylation of 2-methyl-1-indanone proceeded with essentially quantitative conversion to the α -formyl ketone, the only other product in the crude mixture was DMF. This had been reformed from the corresponding chloroiminium salt during the hydrolytic work up. It was known that DMF is highly water soluble, and so it was washed out of the crude mixture in the following manner: the reaction was repeated and after the hydrolysis step, the dichloromethane was removed *in vacuo*, and the remaining aqueous phase was extracted with a mixture of pentane (200 mL) and diethyl ether (30 mL). Following removal of the aqueous layer, the organic layer was washed with saturated aqueous sodium hydrogen carbonate (2 \times 100 mL). The combined organic layers were then dried over magnesium sulfate, filtered, and the solvent was removed *in vacuo* to afford the α -formylated product **169** as a pale yellow oil (88% isolated yield).

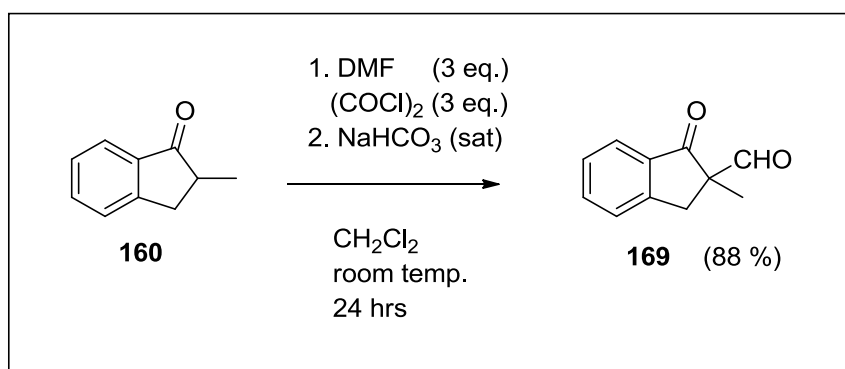

Scheme 72 α -Formylation of 2-methyl-1-indanone.

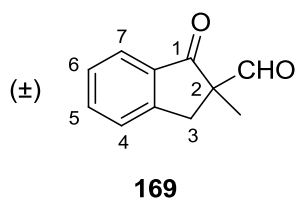

Figure 7

^1H NMR analysis of product **169** gave a 3H singlet at δ 1.55 ppm corresponding to the methyl protons and two 1H doublets at δ 2.85 ppm, $J = 17$ Hz and at δ 3.83 ppm, $J = 17$ Hz, corresponding to the diastereotopic CH_2 protons at position 3. The aromatic protons appeared as a 1H triplet at δ 7.37 ppm, $J = 8$ Hz, corresponding to the proton at position 5, a 1H doublet at δ 7.45 ppm, $J = 8$ Hz, corresponding to the proton at position 4, a 1H triplet at δ 7.59 ppm, $J = 8$ Hz, corresponding to the proton at position 6, and a 1H doublet at δ 7.76 ppm, $J = 8$ Hz, corresponding to the proton at position 7 (shifted furthest downfield due to its close proximity to the carbonyl group). The aldehyde proton appeared as a 1H singlet at δ 9.59 ppm. In the ^{13}C NMR the ketone carbon absorbed at δ 202.4 ppm and the aldehyde carbon absorbed at δ 196.5 ppm. Analysis by infrared spectroscopy gave absorptions at 1736 cm^{-1} and 1704 cm^{-1} corresponding to the aldehyde and ketone carbonyl bonds respectively.

At this stage it was deemed desirable to prepare the α -formyl ketone of 2-methyl-1-tetralone using the same method. This was because the product of that reaction, 2-methyl-1-oxo-1,2,3,4-tetrahydronaphthalene-2-carbaldehyde **170**, is a known compound, and its isolation and identification would have enabled us to ascertain that the transformation did indeed give the α -formyl ketone as the product.

2-Methyl-1-tetralone **161** was reacted with 3 equivalents of $\text{DMF}/(\text{COCl})_2$, in dichloromethane, at room temperature for 1 hour, followed by work up with aqueous base (NaHCO_3). Analysis of the crude mixture indicated that formylation had occurred with a percentage conversion of 19%. The reaction was repeated, this time by heating at reflux (38°C) for 3 hours, and the percentage conversion increased to 50%. Column chromatography with hexane / ethyl acetate (20:1) gave the product **170** as a colourless oil (16 % isolated yield). However, a significant amount of the product was lost due to decarbonylation on the silica column. Spectroscopic

analysis of product **170** confirmed its identity, and agreed with data contained in the literature (it was previously made by methylation of α -hydroxymethylene tetralone).¹⁰¹

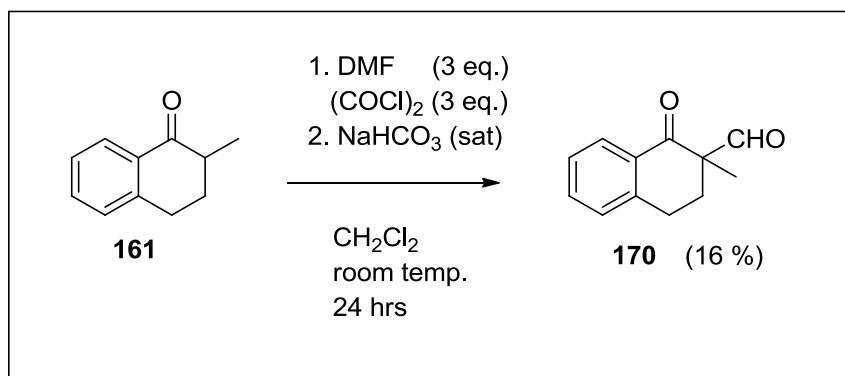

Scheme 73 α -Formylation of 2-methyl-1-tetralone.

2.7 Variation of reaction parameters

With a view to optimising the conditions of the reaction, it was necessary to investigate whether or not the other reaction parameters, in particular temperature, solvent and the nature of the iminium salt itself, had any bearing on it. So far the reactions had been conducted using dichloromethane as the solvent. Intuitively, it was expected that the relatively polar chloroiminium salt might be less solvated, and therefore more reactive, in a less polar reaction medium. A set of experiments were conducted where 2-methyl-1-tetralone was reacted with DMF/(COCl)₂ in different solvents under otherwise identical conditions and Table 17 shows the results obtained:

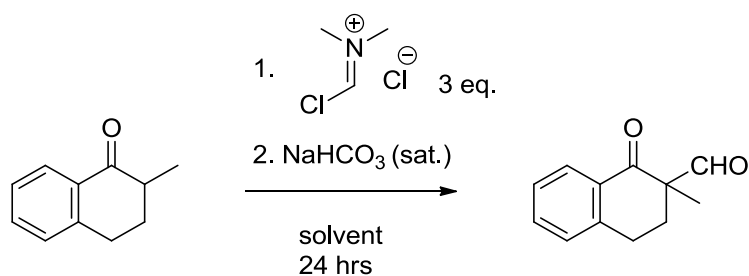

Scheme 74 α -Formylation of 2-methyl-1-tetralone in different solvents.

Table 17 α -Formylation of 2-methyl-1-tetralone in different solvents.

solvent	% conversion
dichloromethane	27
chloroform	26
diethyl ether	0
tetrahydrofuran	0
toluene	0

In the non-chlorinated solvents the chloroiminium salt precipitated out of solution. This probably explains why no reaction was observed, rather than any lack of reactivity of the chloroiminium salt in those solvents. It was expected that the chloroiminium salt would be less solvated, and therefore more reactive in a less polar reaction medium. Evidently though, the solvent must be polar enough to allow for the presence of at least a minimum concentration of the chloroiminium salt, for there to be any reaction at all. The role of temperature was also investigated. When 2-methyl-1-indanone was reacted with $\text{DMF}/(\text{COCl})_2$ at room temperature for 24 hours, quantitative conversion to the α -formyl ketone was obtained. However, 2-methyl-1-tetralone was a less reactive substrate, and an ideal one for probing the extent to which temperature and reaction time affected the level of conversion to the product and Table 18 shows the results obtained.

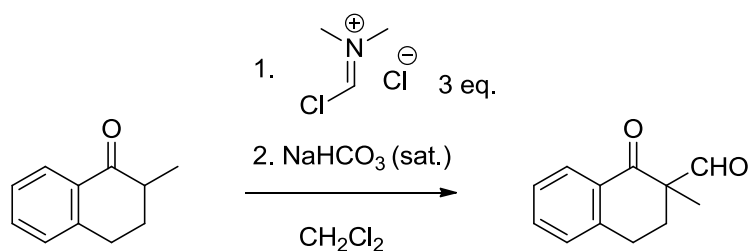

Scheme 75 α -Formylation of 2-methyl-1-tetralone at different temperatures.

Table 18 α -Formylation of 2-methyl-1-tetralone at different temperatures.

temperature ($^{\circ}\text{C}$)	reaction time (hrs)	% conversion
20	24	19
20	48	40
38	3	50
38	24	83

Evidently, both reaction time and temperature are significant factors in this particular reaction, the percentage conversion increased by just over twofold, from 19% to 40%, when the reaction time was doubled from 24 hrs to 48 hrs. It was found that a higher percentage conversion of 50% could be achieved simply by heating the reaction at reflux for 3 hrs. By heating the reaction at reflux (38°C) for 24 hrs a good level of conversion (83%) was obtained.

2.8 Variation of the halo substituent and counter ion

So far, all of the formylation experiments had been conducted using the chloroiminium salt derived from the reaction of oxalyl chloride with either dimethylformamide or *N*-formyl-(*S*)-proline methyl ester. It was necessary to investigate whether the identity of the halo substituent and counter ion on the iminium salt, had any bearing on the level of conversion to the product under set conditions. Experiments with iminium salts derived from phosphorus oxychloride, phosphorus oxybromide and oxalyl bromide were conducted as follows: DMF was dissolved in dichloromethane at 0°C followed by addition of the acid halide and the solution stirred at 0°C .

The ketone (1/3 eq.) was then added and the reaction mixture was allowed to warm to room temperature and stirred for a further 24 hrs, followed by work up with aqueous base (NaHCO₃).

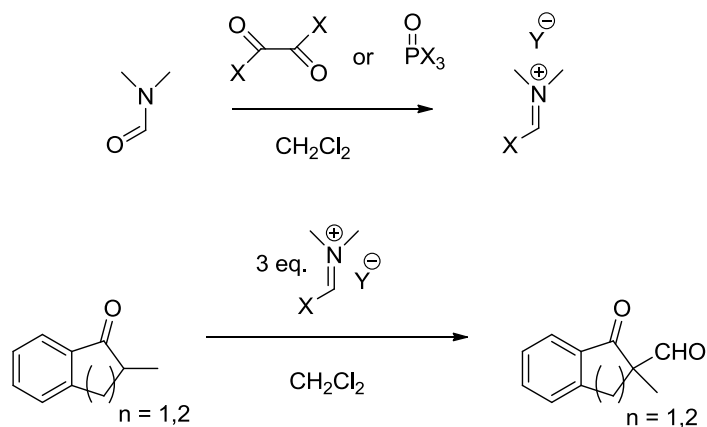

Scheme 76 Variation of halo-substituent and counter ion in the α -formylation of 2-methyl-1-indanone and 2-methyl-1-tetralone.

Table 19 Variation of halo-substituent and counter ion in the α -formylation of 2-methyl-1-indanone and 2-methyl-1-tetralone.

entry	n	time (hrs)	temp (°C)	X	Y	% conversion
1	1	24	20	Cl	Cl	>99
2	2	24	20	Cl	Cl	19
3	2	24	20	Cl	PO ₂ Cl ₂	10
4	2	24	20	Br	Br	0
5	2	24	20	Br	PO ₂ Br ₂	0
6	2	24	38	Cl	Cl	83

The above results indicated that the iminium salts derived from phosphorus oxybromide and oxalyl bromide were unreactive. The most likely explanation is that the corresponding iminium salts did not form under the conditions used. Both phosphorus oxybromide and oxalyl bromide are very reactive with respect to hydrolysis and may have reacted with small amounts of moisture in the solvent.

2.9 Competitive α -formylation versus chloro-enal formation

To investigate the relative reactivities of indanones **160** and **171** a competition experiment was conducted. To a solution containing 1 equivalent each of the two ketones, was added 1 equivalent of DMF/ $(\text{COCl})_2$, in dichloromethane, and the reaction mixture stirred at room temperature for 24 hours. After work up with aqueous base, the crude material was analysed by ^1H NMR spectroscopy to determine the ratio of two products, the α -formyl ketone **169** and the chloroenal **172**. The competitive α -formylation versus chloro-enal formation experiment indicated that α -formylation occurred faster, the percentage conversions being 68%:32% respectively, which gave an indication of the relative reactivities at the corresponding sites of formylation (Scheme 77).

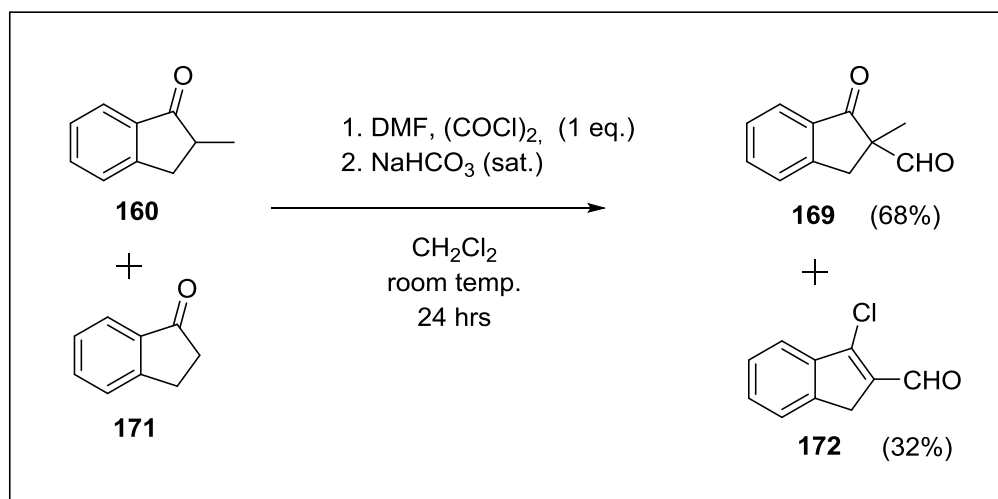

Scheme 77 Competitive α -formylation vs chloro-enal formation.

At this stage it was deemed desirable to extend the methodology to other α -substituted ketones. Some of them were available commercially, while others had to be prepared from commercially available starting materials, and their preparation will now be described.

2.10 Preparation of α -substituted ketones **174**, **176** and **177**

An attempt to prepare 2-benzyl-1-indanone from 1-indanone using the same method as that for the synthesis of 2-methyl-1-indanone (*i.e.* treatment with lithium diisopropylamide, in tetrahydrofuran, at -78°C to form the lithium enolate, followed by a dropwise addition of benzyl bromide) was unsuccessful. The material isolated after work up contained a negligible amount of the desired product. Analysis of the crude material by ^1H NMR gave a 1H doublet at δ 2.69 ppm, $J = 13$ Hz, a 1H doublet at δ 3.07 ppm, $J = 13$ Hz, a 1H triplet at δ 4.99 ppm, $J = 11$ Hz, and a 10H multiplet at δ 7.01 - 7.33 ppm.

Evidently the lithium enolate had not been formed, and instead the benzyl bromide had been deprotonated by LDA and reacted with itself to form **173** (Scheme 78). (Literature ^1H NMR data for compound **173**: $\delta = 3.48$ (d, 2H), $\delta 5.00$ (t, 1H), $\delta 7.30$ (s, 5H), $\delta 7.40$ (s, 5H).¹⁰² The data obtained was roughly in agreement with the above literature data, except for the signals corresponding to the diastereotopic CH_2 protons (adjacent to the chiral centre). The data obtained gave two 1H doublets at δ 2.69 ppm and δ 3.07 ppm ($J = 13$ Hz) which is expected for a pair diastereotopic CH_2 protons, whereas in the literature they were reported as a 2H doublet at δ 3.48 ppm.

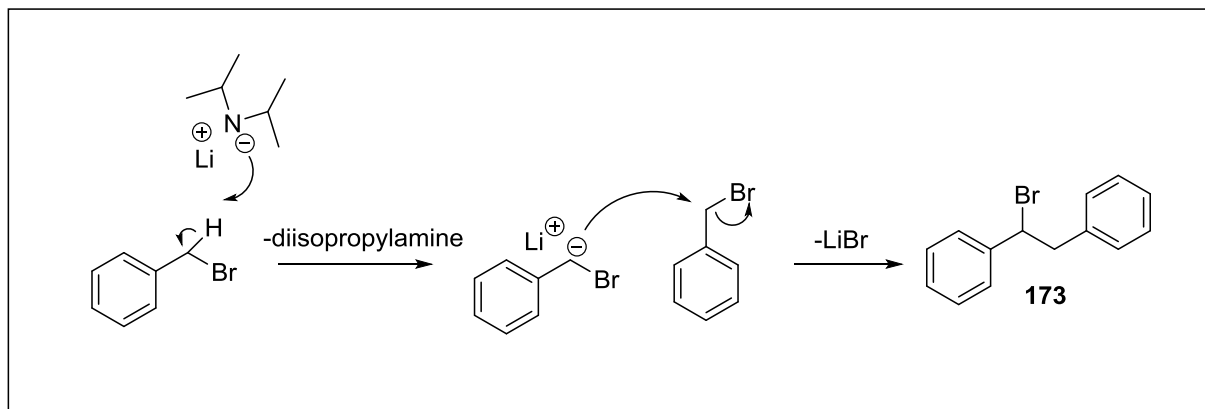

Scheme 78 Proposed mechanism for the formation of side product **173**.

In order to solve this problem, the reaction conditions were modified in the following way: 1-indanone was added to the LDA solution at -78°C as before, and the solution was then allowed to warm to 0°C and stirred for 30 mins at that temperature in order to force the formation of the lithium enolate. The temperature was then taken back down to -78°C followed

by a slow dropwise addition of benzyl bromide. Aqueous work up followed by column chromatography gave (\pm) 2-benzyl-1-indanone **174** as a yellow oil (34% isolated yield).

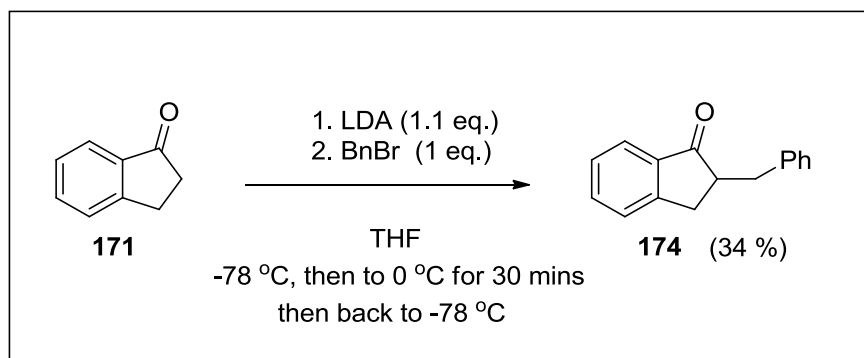

Scheme 79 Preparation of (\pm) 2-benzyl-1-indanone.

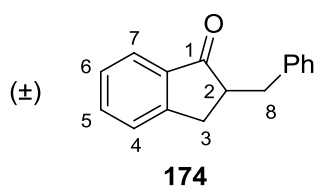
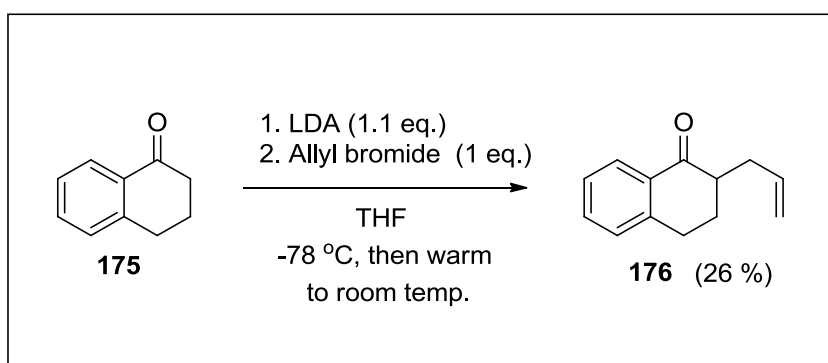

Figure 8

¹H NMR analysis of product **174** indicated that it was the desired compound. There are two sets of diastereotopic CH₂ protons, at positions 3 and 8. Both are diastereotopic because they are adjacent to a stereogenic centre. First the CH₂ protons at position 8; these split each other into a doublet with a germinal coupling ²*J* and are split into a doublet again by the adjacent proton attached to the stereogenic centre (position 2), hence a double doublet should be observed for these protons. This was observed in the spectrum and appeared as a 1H double doublet at δ 2.63 ppm, *J* = 13, 11 Hz, and another a second 1H double doublet at δ 3.38 ppm, *J* = 13, 4 Hz. A similar pattern is expected for the CH₂ protons at position 3 and this was also observed and appeared as a 1H double doublet at δ 2.84 ppm, *J* = 16, 4 Hz, and a second 1H double doublet at δ 3.15 ppm, *J* = 16, 8 Hz. The proton attached to the stereogenic centre is split by four neighbouring diastereotopic protons and appeared as a 1H multiplet at δ 2.91-3.02 ppm. The aromatic protons appeared as a 7H multiplet at δ 7.17-7.39 ppm, a 1H triplet at δ

7.55 ppm, $J = 8$ Hz, and a 1H doublet at δ 7.75 ppm, $J = 8$ Hz. This data was in agreement with that reported in the literature for this compound.¹⁰³

For the preparation of 2-allyl-1-tetralone **175**, the same method was used as that for the synthesis of 2-methyl-1-tetralone *i.e.* treatment with lithium diisopropylamide in tetrahydrofuran, at -78 °C to form the lithium enolate, followed by a dropwise addition of allyl bromide. After hydrolytic work up, the material was purified by column chromatography (SiO_2) with hexane / ethyl acetate (10:1) to afford the product **176** as a colourless oil (26% isolated yield).



Scheme 80 Preparation of (\pm) 2-allyl-1-tetralone.

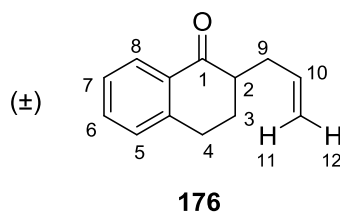
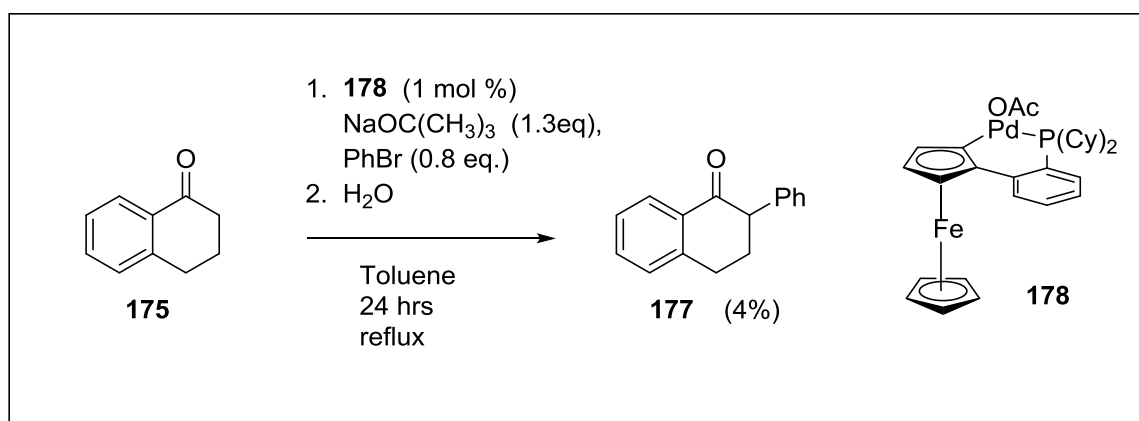

Figure 9

^1H NMR analysis of product **176** gave a 1H multiplet at δ 1.65-1.75 ppm corresponding to the one of the CH_2 protons at position 3, a 2H multiplet at δ 2.13-2.26 ppm corresponding to the other CH_2 proton at position 3 and also the CH proton attached to the stereogenic centre (position 2). The diastereotopic CH_2 protons at position 9 appeared as a 1H multiplet at δ 2.42-2.53 ppm and a 1H multiplet at δ 2.66-2.75 ppm. The CH_2 protons at position 4 appeared as a

2H multiplet at δ 2.81-2.84 ppm. The vinyl proton at position 10 appeared as a 1H multiplet at δ 5.63-5.77 ppm. The signal for this proton is split by the two terminal vinyl protons at positions 11 and 12, and also by the neighbouring CH₂ protons at position 9. The terminal vinyl protons appeared as a 1H doublet at 5.02 ppm, $J = 10$ Hz, and another 1H doublet at δ 5.06 ppm, $J = 16$ Hz, for the protons at positions 12 and 11 respectively. The aromatic protons occurred as a 1H doublet at δ 7.14 ppm, $J = 8$ Hz, corresponding to the proton at position 5, a 1H triplet at δ 7.16 ppm, $J = 8$ Hz for the proton at position 6, a 1H triplet at δ 7.30 ppm, $J = 8$ Hz for the proton at position at position 7 and a 1H doublet at δ 7.89 ppm, $J = 8$ Hz corresponding to the proton at position 8. This data was in agreement with that reported in the literature for this compound.¹⁰⁴

For the preparation of 2-phenyl-1-tetralone **177** from 1-tetralone **175**, the following method was used: sodium *tert*-butoxide and a catalytic quantity of palladio-phosphorus compound **178** (obtained from a colleague in the laboratory who was working on asymmetric synthesis using palladio-phosphorus catalysts)¹⁰⁵ were placed in a schlenk flask, under argon, and dissolved in toluene. Then bromobenzene and α -tetralone were added to the solution and the mixture heated at reflux for 24 hours. Following aqueous work up, the crude material was purified by column chromatography (SiO₂) with hexane / ethyl acetate (20:1) which gave the product **177** as a pale orange oil (4% isolated yield).



Scheme 81 Preparation of (±) 2-phenyl-1-tetralone.

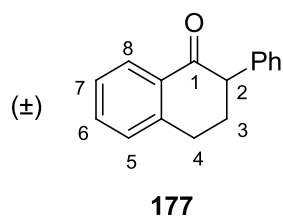

Figure 10

^1H NMR analysis of product **177** gave a 2H multiplet at δ 2.37-2.48 ppm corresponding to the CH_2 protons at position 3, a 2H multiplet at δ 2.99-3.15 ppm corresponding to the CH_2 protons at position 4, and a 1H double doublet at δ 3.79 ppm, $J = 8, 4$ Hz, corresponding to the proton attached to the stereogenic centre (position 2). The aromatic protons appeared as a 7H multiplet at δ 7.16-7.37 ppm, a 1H triplet at δ 7.49 ppm, $J = 8$ Hz, and a 1H doublet at δ 8.10 ppm, $J = 8$ Hz. This data was in agreement with that reported in the literature for this compound.¹⁰⁶

2.11 Modification of the chromatography conditions in order to inhibit decarbonylation

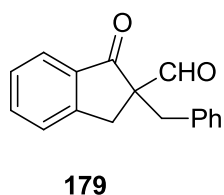
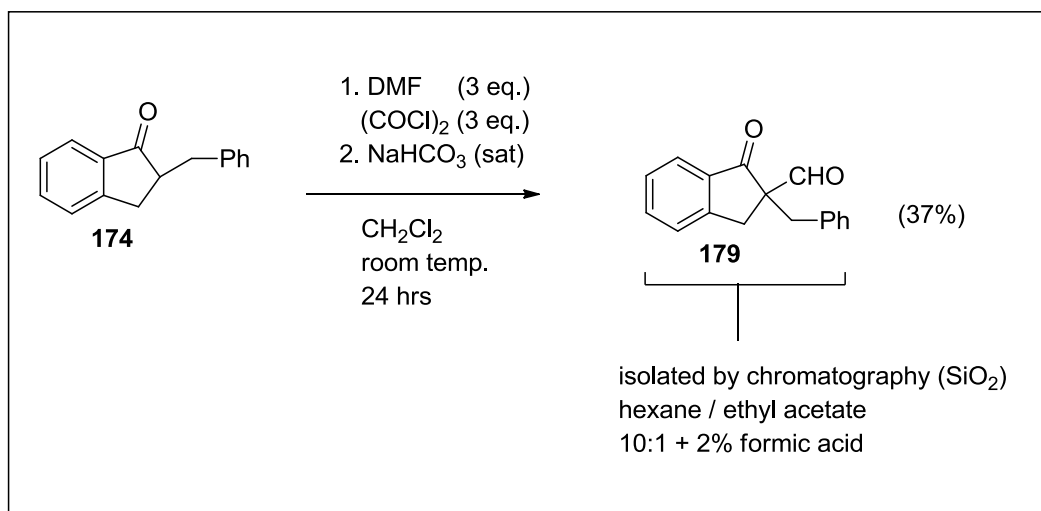

Figure 11

The formylation of 2-benzyl-1-indanone **174**, using the standard formylation conditions, gave a crude product whose ^1H NMR indicated that it was the α -formyl ketone **179** (2-benzyl-1-oxoindane-2-carbaldehyde). However the isolation of this product was problematic due to its decarbonylation on the silica column during chromatography. Although ^1H NMR analysis of the unpurified material obtained after the reaction indicated that the α -formyl ketone product had been formed, it still contained a significant amount of starting material. So although the DMF could be removed by an aqueous wash, this would not have removed the starting material. An attempt to purify the product by distillation at low pressure (using a Kugelrohr apparatus) was unsuccessful, probably due to decarbonylation of the product. It seemed that chromatography was the only viable purification method available, which meant that the problem of decarbonylation on silica needed to be circumvented. It was known that silica was

slightly acidic and therefore an experiment was conducted where a small amount of the unpurified material was chromatographed using aluminium oxide as the stationary phase rather than silica. It was reasoned that since aluminium oxide is neutral, that decarbonylation might be inhibited, if indeed it was the acidity of the silica stationary phase that was promoting the decarbonylation. Contrary to intuition, the result indicated that almost complete decarbonylation had occurred when aluminium oxide was used as the stationary phase, about as much as occurred when silica was used.

Next, an experiment was conducted where the chromatography was performed under basic conditions. Silica was used as the stationary phase along with a mobile phase containing triethylamine (2% Et₃N in 10:1 hexane/ethyl acetate). The result indicated that complete decarbonylation had occurred under these conditions. However, an experiment with an acidic mobile phase (2% formic acid in 10:1 hexane/ethyl acetate) with silica as the stationary phase indicated that decarbonylation was inhibited under these conditions, and it was possible to isolate the pure product **179** (37% isolated yield). Possible mechanisms for this decarbonylation process are discussed later in this chapter.



Scheme 82 Isolation of α -formyl ketone **179** by chromatography using an acidic mobile phase.

2.12 Preparative α -formylation of various substrates.

In order to illustrate the general usefulness of the transformation, the methodology was applied to a total of 9 substrates (Table 20):

Table 20 Preparative α -formylation reactions.^a

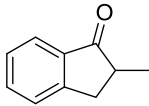
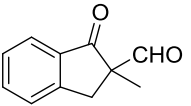
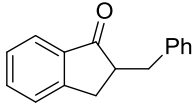
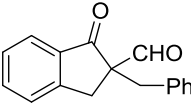
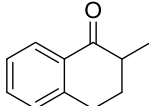
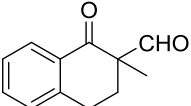
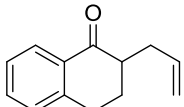
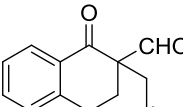
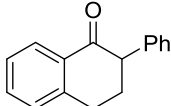
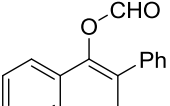
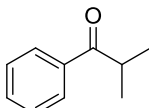
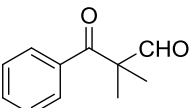
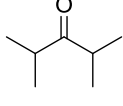
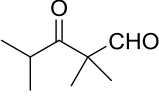
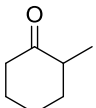
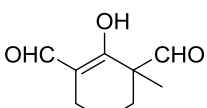
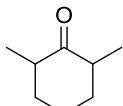
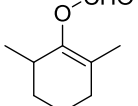
Entry	Temp (°C)	Ketone	Product	Conversion (%) ^b	Yield (%)
1	20			>99	88 ^c
2	20			89	37 ^d
3	38			83	34 ^d
4	38			74	45 ^d
5	38			85	84 ^d
6	38			11	8 ^d
7	38			59	40 ^d
8	38			72	29 ^d
9	38			50	29 ^d

(a) Conditions: 3 equiv of *in situ* generated **133**, CH₂Cl₂, 24 h. (b) Determined by ¹H NMR.

(c) Isolated by aqueous workup. (d) Isolated by column chromatography.

Several of the substrates in Table 20 reacted to give their corresponding α -formyl ketones with significantly higher percentage conversions than the isolated yields. This was largely due to the fact that the products underwent a certain amount of decarbonylation during chromatography, although this was minimised by using an acidic mobile phase as described. For entries 8 and 9 the isolated yields were both 29%.

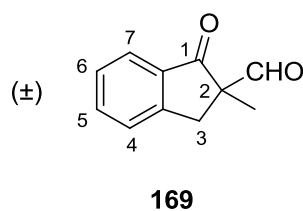

Figure 12

Product **169** (2-methyl-1-oxoindane-2-carbaldehyde) was a novel compound, and was obtained using the conditions described in Table 20 with an isolated yield of 88%. α -Methylindanone **160** was the most reactive substrate in the series and reacted at room temperature, after 24 hours, to give quantitative conversion to the α -formyl ketone. Therefore an aqueous wash was sufficient to remove DMF from the reaction mixture, affording the pure product in good yield (88%) without the need for chromatography. ^1H NMR analysis of the isolated material gave a 3H singlet at δ 1.55 ppm corresponding to the methyl protons, a 1H doublet at δ 2.85 ppm, $J = 17$ Hz, and another at 1H doublet at δ 3.83 ppm, $J = 17$ Hz, corresponding to the diastereotopic CH_2 protons at position 3. The aromatic protons at positions 5 and 6 gave 1H triplets at δ 7.37 ppm, $J = 8$ Hz, and δ 7.59 ppm, $J = 8$ Hz, respectively. The aromatic protons at positions 4 and 7 appeared as 1H doublets at δ 7.45 ppm, $J = 8$ Hz, and δ 7.76 ppm, $J = 8$ Hz, respectively. The aldehyde proton appeared as a singlet at δ 9.59 ppm. In the ^{13}C NMR the ketone carbon absorbed at δ 202.4 ppm and the aldehyde carbon absorbed at δ 196.5 ppm. Analysis by infrared spectroscopy gave absorptions at 1736 cm^{-1} and 1704 cm^{-1} corresponding to the aldehyde and ketone carbonyl bonds respectively. High resolution mass spectrometry (m/z , ES) for the molecular ion MH^+ gave 175.0752; required 175.0754.

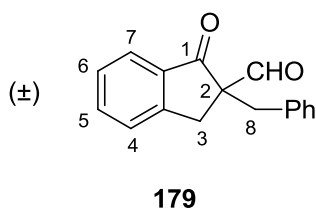

Figure 13

Product **179** (2-benzyl-1-oxoindane-2-carbaldehyde) was also a novel compound, and was obtained using the conditions described in Table 20 with an isolated yield of 37%. Although the level of conversion to the product was high (89%), a considerable amount of it was lost during chromatography as result of decarbonylation of the product. ^1H NMR analysis of the isolated material gave a 1H doublet at δ 2.98 ppm, $J = 18$ Hz, and another 1H doublet at δ 3.62 ppm, $J = 18$ Hz, corresponding to the diastereotopic protons at position 3. The other two diastereotopic protons, at position 8, gave 1H doublets at δ 3.32 ppm, $J = 14$ Hz, and δ 3.42 ppm, $J = 14$ Hz. The signals due to the aromatic protons occurred as follows: the aromatic protons of the benzyl group occurred as a 5H multiplet at δ 7.08-7.22 ppm, the proton at position 5 appeared as 1H triplet at δ 7.32 ppm, $J = 8$ Hz, the proton at position 4 appeared as 1H doublet at δ 7.39 ppm, $J = 8$ Hz, the proton at position 6 appeared as a 1H triplet at δ 7.55 ppm, $J = 8$ Hz, and the proton at position 7 appeared as a 1H doublet at δ 7.69 ppm, $J = 8$ Hz. The aldehyde proton appeared as a singlet at δ 9.70 ppm. Analysis by IR spectroscopy gave absorptions at 1735 cm^{-1} and 1701 cm^{-1} for the aldehyde and ketone carbonyl bonds respectively. High resolution mass spectrometry (m/z , ES) for the molecular ion $[\text{M}+\text{NH}_4]^+$ gave 268.1336; required 268.1332.

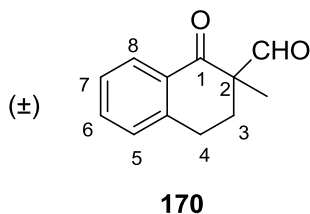

Figure 14

Product **170** (2-methyl-1-oxo-1,2,3,4-tetrahydronaphthalene-2-carbaldehyde) was a known compound,¹⁰¹ and was obtained using the conditions described in Table 20, with an isolated yield of 34%. A significant amount of the material was lost during chromatography due to

decarbonylation. ^1H NMR analysis of the isolated material gave a 3H singlet at δ 1.39 ppm corresponding to the methyl protons. The CH_2 protons at position 3 appeared as a 1H double double doublet at δ 1.98 ppm, $J = 14, 8, 5$ Hz, and a 1H double double doublet at δ 2.48 ppm, $J = 14, 8, 5$ Hz. The CH_2 protons at position 4 appeared as a 2H multiplet at δ 2.96-3.06 ppm. The signals due to the aromatic protons occurred as follows: the proton at position 5 gave a 1H doublet at δ 7.23 ppm, $J = 8$ Hz, the proton at position 6 gave a 1H triplet at δ 7.31 ppm, $J = 8$ Hz, the proton at position 7 gave a 1H triplet at δ 7.49 ppm, $J = 8$ Hz, and the proton at position 8 gave a 1H doublet at δ 8.02 ppm, $J = 8$ Hz. The aldehyde proton appeared as a singlet at δ 9.73 ppm. Analysis by IR spectroscopy gave absorptions at 1724 cm^{-1} and 1671 cm^{-1} for the aldehyde and ketone carbonyl bonds respectively. This data was in agreement with that reported in the literature for this compound.¹⁰¹

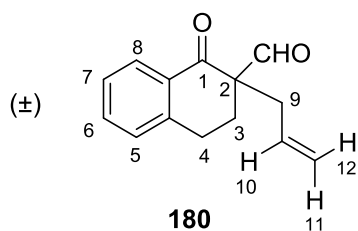

Figure 15

Product **180** (2-allyl-1-oxo-1,2,3,4-tetrahydronaphthalene-2-carbaldehyde) was a novel compound and was obtained using the conditions described in Table 20 with an isolated yield of 45%. ^1H NMR analysis gave a 1H double double doublet at δ 2.06, $J = 14, 8, 5$ Hz and another 1H double double doublet at δ 2.39 ppm, $J = 14, 7, 5$ Hz, both corresponding to the CH_2 protons at position 3. The diastereotopic allyl protons at position 9 appeared as a 2H multiplet at δ 2.59-2.70 ppm. The CH_2 protons at position 4 appeared as a 2H multiplet at δ 2.87-3.03 ppm. The vinyl proton at position 11 appeared as an unresolved 1H multiplet δ 5.07-5.09 ppm, and the vinyl proton at position 12 appeared as a 1H multiplet at δ 5.10-5.13 ppm. This signal for proton 12 is split by a relatively large 3J *trans* coupling to proton 10 which should give a doublet, and by a small 2J geminal coupling to proton 11 which should give another pair of doublets, and finally by a small 4J coupling to the diastereotopic allyl protons at position 9. In theory this should give rise to a double double triplet splitting pattern, but the overlapping of signals gives it the appearance of a double multiplet, with the two multiplets overlapping at their bases, and therefore this signal has been reported as a 1H multiplet

occurring at δ 5.10-5.13 ppm. The vinyl proton at position 10 occurred as a 1H multiplet at δ 5.56-5.67 ppm. The signal for this proton is split by a 3J coupling to the two diastereotopic allyl protons at position 9, and also by a 3J coupling to the *cis* and *trans* vinyl protons at positions 11 and 12 respectively. The signals due to the aromatic signals occurred as follows: the proton at position 5 appeared as 1H doublet at δ 7.18 ppm, $J = 8$ Hz, the proton at position 6 appeared as 1H triplet at δ 7.29 ppm, $J = 8$ Hz, the proton at position 7 appeared as a 1H triplet at δ 7.45 ppm, $J = 8$ Hz, and the proton at position 8 appeared as a 1H doublet at δ 7.98 ppm, $J = 8$ Hz. The aldehyde proton appeared as a singlet at δ 9.70 ppm. Analysis by IR spectroscopy gave absorptions at 1731 cm^{-1} and 1672 cm^{-1} for the aldehyde and ketone carbonyl bonds respectively. High resolution mass spectrometry (m/z , ES) for the molecular ion MH^+ gave 215.1070; required 215.1067.

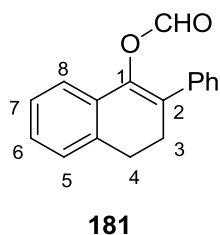

Figure 16

Product **181** (2-phenyl-3,4-dihydronaphthalen-1-yl formate) was a novel compound and was obtained using the conditions described in Table 20 with an isolated yield of 84%. Analysis by ^1H NMR gave a 2H triplet at δ 2.73 ppm, $J = 8$ Hz, corresponding to the CH_2 protons at position 3 and another 2H triplet at δ 2.90 ppm, $J = 8$ Hz, corresponding to the CH_2 protons at position 4. The aromatic protons appeared in the region δ 7.07-7.32 ppm, and the aldehyde proton appeared as a singlet at 7.92 ppm. Analysis by IR spectroscopy gave an absorption at 1739 cm^{-1} for the carbonyl bond. High resolution mass spectrometry (m/z , ES) gave 269.1359 for the molecular ion $[\text{M}+\text{NH}_4]^+$; required 269.1366. This compound is a formate ester, and not the expected α -formyl ketone. Presumably the presence of the phenyl group at the α position, inhibits attack by the electrophile at that position due to steric hindrance. The enol of the substrate is expected to be stable due to conjugation with the phenyl group, and this may have rendered it less nucleophilic at the double bond and more so at the hydroxyl group.

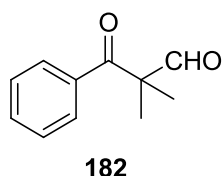

Figure 17

Product **182** (2,2-dimethyl-3-oxo-3-phenylpropanal) was a known compound,¹⁰⁸ and was obtained using the conditions described in Table 20 with an isolated yield of 11%. Analysis by ¹H NMR gave a 6H singlet at δ 1.46 ppm for the two sets of methyl protons. The aromatic protons occurred in the region δ 7.41-7.75 ppm, and the aldehyde proton occurred at δ 9.75 ppm. This data was in agreement with that reported in the literature for this compound.¹⁰⁷

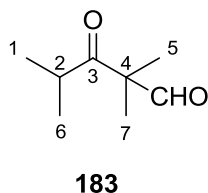

Figure 18

Product **183** (trimethyl-3-oxopentanal) was a known compound,¹⁰⁹ and was obtained using the conditions described in Table 20 with an isolated yield of 40%. Analysis by ¹H NMR gave a 6H doublet at δ 1.00 ppm, $J = 7$ Hz, corresponding to the methyl protons at positions 1 and 6, a 6H singlet at δ 1.28 ppm for the methyl protons at positions 5 and 7, a 1H septet at δ 2.86 ppm, $J = 7$ Hz, corresponding to the CH proton at position 2, and a 1H singlet at δ 9.59 ppm corresponding to the aldehyde proton. This data was agreement with that reported in the literature for this compound.¹⁰⁸

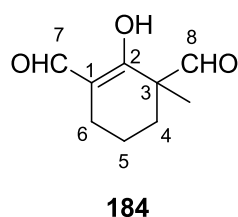

Figure 19

Product **184** (2-hydroxy-3-methylcyclohex-1-ene-1,3-dicarbaldehyde) was a novel compound and was obtained using the conditions described in Table 20 with an isolated yield of 29%. Analysis by ^1H NMR gave a 3H singlet at δ 1.41 ppm corresponding to the methyl protons, a 3H multiplet at δ 1.50-1.64 ppm for the two protons at position 5 (since these are the furthest from the electron-withdrawing formyl groups and therefore the most shielded) and one of the protons at position 4, a 1H multiplet at δ 1.95-2.04 ppm for the remaining proton at position 4, and a 2H multiplet at δ 2.25-2.29 ppm corresponding to the CH_2 protons at position 6. The aldehyde protons at position 8 and 7 appeared as 1H singlets at δ 9.44 ppm and δ 10.17 ppm respectively. The OH absorption was not visible in the observed spectral range (δ 0-10.5 ppm). Analysis by IR spectroscopy gave absorptions at 1680 cm^{-1} and 1735 cm^{-1} corresponding to the carbonyl bonds at positions 7 and 8 respectively, although an OH absorption was not visible in the IR. High resolution mass spectrometry (m/z, ES) did not give the expected molecular ion, probably because the material had decomposed by the time the experiment was conducted.

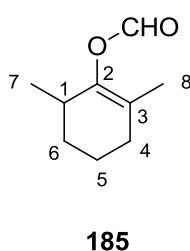

Figure 20

Product **185** (dimethylcyclohex-1-en-1-yl formate) was a novel compound and was obtained using the conditions described in Table 20 with an isolated yield of 29%. Analysis by ^1H NMR gave a 3H doublet at δ 0.94 ppm, $J = 4\text{ Hz}$, corresponding to the methyl protons at position 7, a 1H multiplet at δ 1.32-1.38 ppm corresponding to one of the protons at position 6, a 3H singlet at δ 1.47 ppm corresponding to the methyl protons at position 8, a 1H multiplet at δ 1.49-1.52

ppm for the other proton at position 6. A 1H multiplet appeared at δ 1.53-1.67 ppm corresponding to one of the protons at position 5, and another 1H multiplet at δ 1.76-1.84 ppm corresponding to the other proton at position 5. A 2H multiplet was observed at δ 1.97-2.02 ppm corresponding to the CH₂ protons at position 4 and a 1H multiplet at δ 2.27-2.38 ppm corresponding to the CH proton at position 1. The formyl proton appeared as a singlet at δ 8.01 ppm. Analysis by IR spectroscopy gave an absorption at 1737 cm⁻¹ for the carbonyl group. High resolution mass spectrometry (*m/z*, ES) did not give the expected molecular ion, probably because the material had decomposed by the time the experiment was conducted.

2.13 Proposed mechanism of α -formylation

In order for the ketone to react with the electrophilic chloroiminium salt it must be in a nucleophilic form. One possibility is that a small amount of H⁺ is present in the solution, perhaps due to partial hydrolysis of oxalyl chloride in the chloroiminium salt formation step by small amounts of moisture present in the solution. If so, this allows the ketone to undergo enolisation as illustrated in Scheme 83 (using an α -substituted tetralone as an example). This enolisation of the ketone, in the presence of H⁺, is suggested in the literature.⁹¹ The enol **186** then reacts as a nucleophile and attacks the chloroiminium salt, at the electrophilic carbon, to form intermediate **187**. This intermediate expels a chloride ion to form a second intermediate, iminium ion **188**, which is hydrolysed during aqueous work up to afford the α -formyl ketone product **189**.

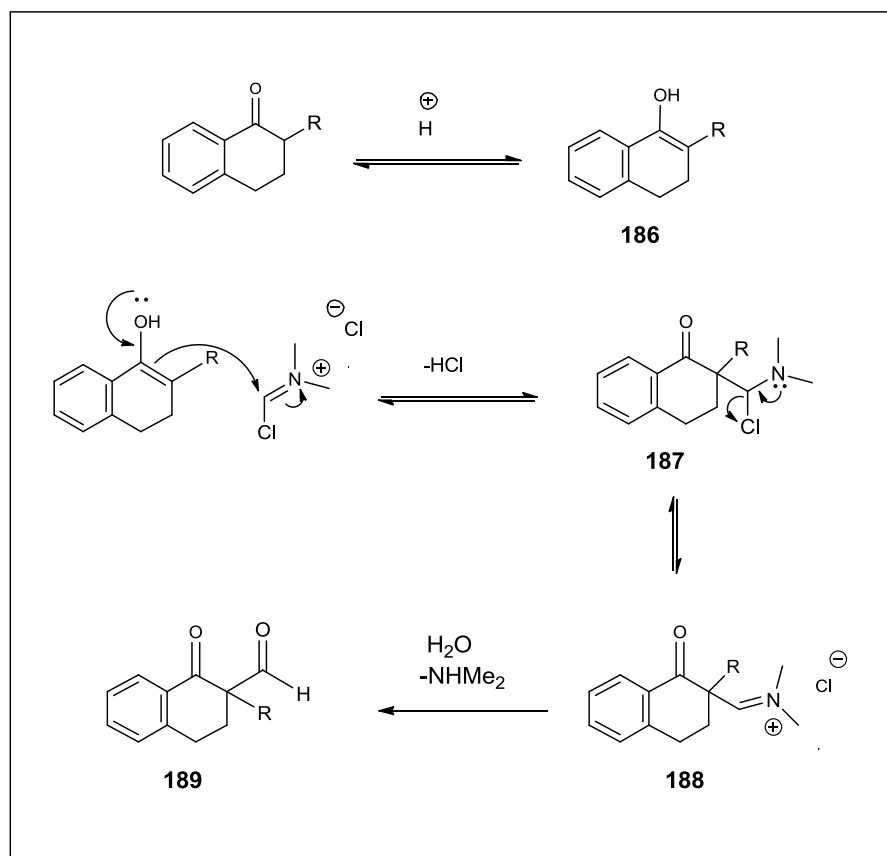

Scheme 83 Proposed mechanism of α -formylation

2.14 Decarbonylation experiments

The proposed formylation mechanism suggested that the decarbonylation mechanism might also occur *via* the formation of an enol. One possibility was that, in the presence of moisture, the α -formyl ketone adds a water molecule to form a hydrate **190**. This is then deprotonated, by any available base, to form an enol, which tautomerises to the thermodynamically more stable keto form. In this mechanism the decarbonylation proceeds *via* an enol intermediate. If correct, it explains why the indanones and tetralones decarbonylate easily. It is for the same reason that they formylate most easily, *i.e.* because the presence of an aromatic group adjacent to the double bond of the enol stabilises its formation and therefore allows it to be formed more easily. The mechanism involves the loss of formate ion, which presumably would be protonated to give formic acid. If the mechanism is correct then it ought to have been possible to detect the presence of formic acid after decarbonylation occurs, which provided a useful way of testing the hypothesis.

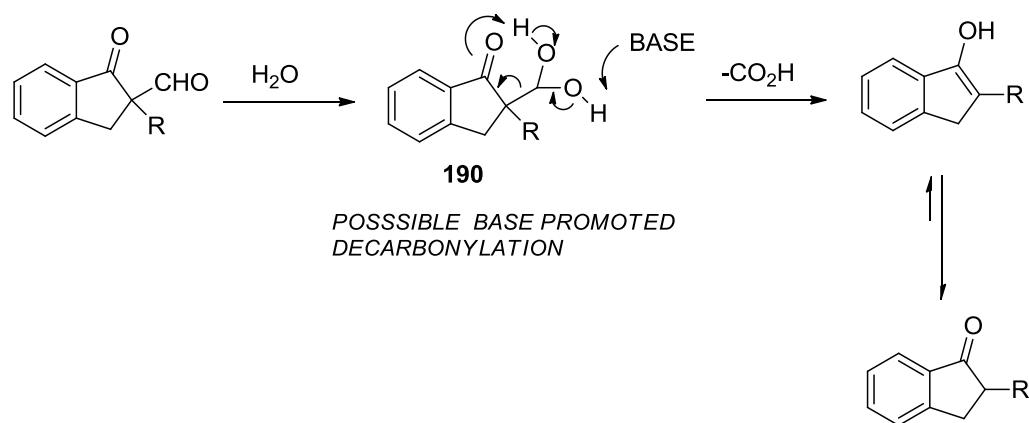

Scheme 84

To test the proposed mechanism the following experiment was conducted: compound **170** (2-methyl-1-oxo-1,2,3,4-tetrahydronaphthalene-2-carbaldehyde) was dissolved in deuterated chloroform, under argon. Then silica was added and the mixture stirred at room temperature for 1 hour. A small aliquot of the mixture was then filtered through cotton wool, to remove silica, and analysed by ^1H NMR spectroscopy, which indicated that complete decarbonylation had occurred, however no peak corresponding to formic acid was observed. Then a second solution containing toluene (added as an internal standard) and formic acid, of the same molarity as the α -formyl ketone solution, was added to the first solution (containing compound **170**) and the solution stirred for an additional 1 hour. A second aliquot was then filtered through cotton wool and analysed by ^1H NMR. The spectrum clearly showed the formamide proton of formic acid as a singlet at δ 7.97 ppm, and the methyl protons of toluene as a singlet at δ 2.26 ppm, as well as signals corresponding to the decarbonylated compound *i.e.* α -methyl tetralone. A control experiment where no silica was added (under otherwise identical conditions) indicated that no decarbonylation had occurred when silica was not present. The experiment indicated that formic acid had not been formed as a by-product of the decarbonylation. Had it been formed, it would have been possible to identify it and also to determine the quantity of it present in solution by comparison with the methyl peak of the toluene internal standard.

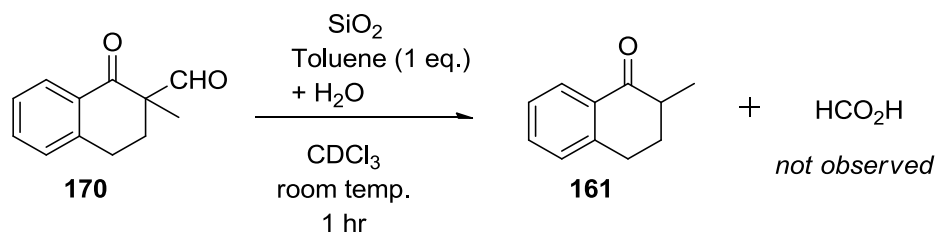

Scheme 85

This experimental result implied that the proposed mechanism, involving the generation of formic acid, was not correct. Another possibility was that the process occurs with the generation of carbon monoxide as illustrated below (Scheme 86):

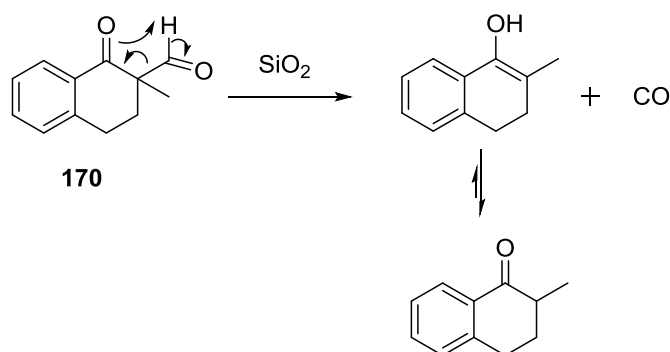

Scheme 86

If this mechanism is correct then it may explain why the decarbonylation was inhibited to a certain extent in acidic conditions. It could be that in acidic conditions the keto-carbonyl oxygen is protonated. If so, this renders it unable to abstract the aldehyde proton and the decarbonylation mechanism is effectively brought to a halt.

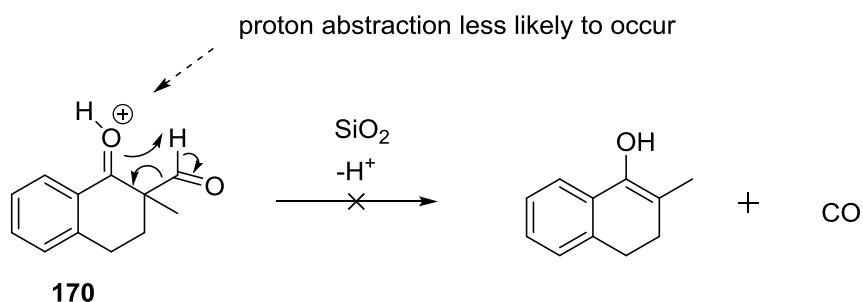

Scheme 87

To test this hypothesis it was necessary to devise a way of detecting carbon monoxide. To do this a carbon monoxide detector was used and the following experiment was conducted: α -methyl tetralone was formylated using DMF/(COCl)₂, to give a crude product whose ¹H NMR spectrum indicated that it contained 2-methyl-1-oxo-1,2,3,4-tetrahydronaphthalene-2-carbaldehyde **170** (83% conversion). The crude product (300 mg) was dissolved in deuterated chloroform in a two necked round bottomed flask, which was connected, *via* a tube, to an air tight plastic bag containing an electronic carbon monoxide detector (Figure 21). Then silica was added and the mixture stirred at room temperature for 1 hour, during which time the carbon monoxide detector did not sound. An aliquot of the mixture was then filtered through cotton wool, to remove silica, and analysed by ¹H NMR spectroscopy, which indicated that complete decarbonylation had occurred. The complete decarbonylation of 300 mg of compound **170** (by the mechanism in scheme 86) generates 38.9 mL of carbon monoxide (at room temperature and pressure) when the reaction goes to completion. A control experiment was also conducted in which the carbon monoxide detector was connected to a flask containing a solution of DMF in dichloromethane, to which was added 1 equivalent of oxalyl chloride and the reaction mixture stirred at room temperature. The reaction between DMF and oxalyl chloride generates a molecule of carbon monoxide and a molecule of carbon dioxide for every molecule of DMF and oxalyl chloride that react.

The molarity of DMF and oxalyl chloride in this solution was one tenth that of the molarity of the first experiment (in which product **170** was used), and the reaction generates 7.78 mL of gas when it goes to completion. In the control experiment there was an instant evolution of gas and the carbon monoxide detector sounded about 10 seconds after the reaction had been initiated. The result of the above experiment indicated that carbon monoxide was not formed.

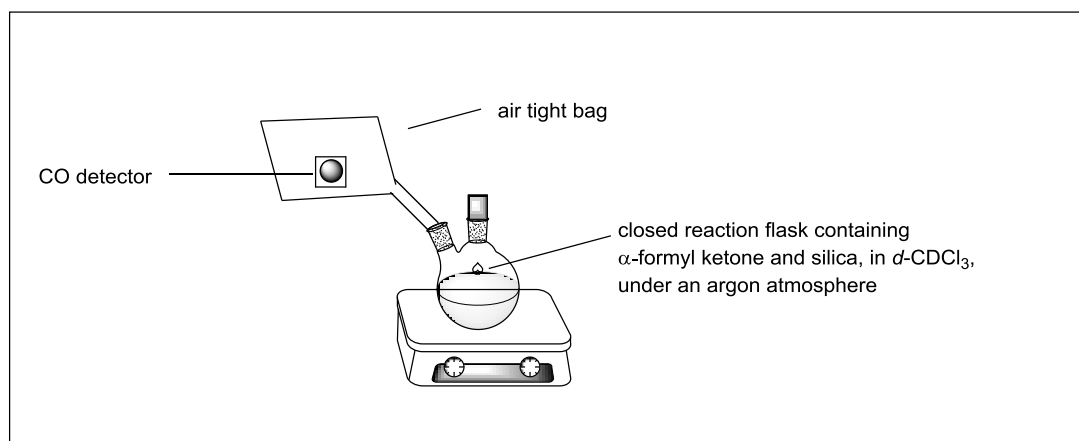

Figure 21

The light induced decarbonylation of tertiary aldehydes by homolytic cleavage is reported in the literature,¹⁰⁹ therefore an experiment was conducted to ascertain whether visible light and atmospheric air had any bearing on the decarbonylation process *i.e.* whether the α -formyl ketone was photocatalytically unstable with respect to decarbonylation. The experiment was conducted as follows: equal amounts of a sample containing a mixture of α -formyl ketone **170** and the starting material **161** (2-methyl-1-tetralone), in the approximate ratio 64% : 36 % respectively, were placed in four separate reaction vessels and to them was added deuterated chloroform (5 mL), and a spatula of silica (except for the control experiment where no silica was added). The reaction mixtures were then stirred for 30 mins under various conditions, and then aliquots of the sample mixtures were filtered through cotton wool to remove silica, and analysed by ¹H NMR spectroscopy. More samples were taken after 24 hours and analysed in the same way. The table below shows the results obtained. (Entry 1 in Table 21 was the control experiment).

Table 21

entry	reaction time (hrs)	silica	air	<i>h</i> ν	ratio of product : starting material
1	0.5	×	✓	✓	64 : 36
2	0.5	✓	✓	✓	50 : 50
3	0.5	✓	✓	×	47 : 53
4	0.5	✓	×	×	48 : 52
5	24	×	✓	✓	56 : 44
6	24	✓	✓	✓	36 : 64
7	24	✓	✓	×	17 : 83
8	24	✓	×	×	28 : 72

The above results indicated that light and atmospheric air were not significant factors in the decarbonylation process and it still remains to ascertain the mechanism of this reaction. It is clear from the above results that the all important factor in the decarbonylation mechanism is the presence of silica. Although conditions have been discovered which inhibit the decarbonylation of these compounds during chromatography, the loss of product by this process was still a drawback to the methodology.

2.15 Reductive amination of α -formyl ketones **169** and **170**

The decarbonylation problem can be circumvented by not attempting to isolate the α -formyl ketone at all. Instead, a derivative of the α -formyl ketone can be prepared which is more stable to chromatography. A method was employed whereby α -formyl ketones **169** and **170** were reductively aminated to afford aminoketones, following a literature procedure.¹¹⁰ The crude α -formyl ketones **169** and **170** were dissolved in 1,2-dichloroethane, and to the solution was added 1.0 equivalent of benzylamine, 1.5 equivalent of sodium triacetoxyborohydride and 1 equivalent of acetic acid, and the reaction mixtures stirred under argon for 2 hours at room temperature. Following work up with saturated aqueous NaHCO_3 , the crude materials were purified by column chromatography (SiO_2) with 3% $\text{MeOH-CH}_2\text{Cl}_2$ to give the aminoketone products **191** and **192** (Scheme 88).

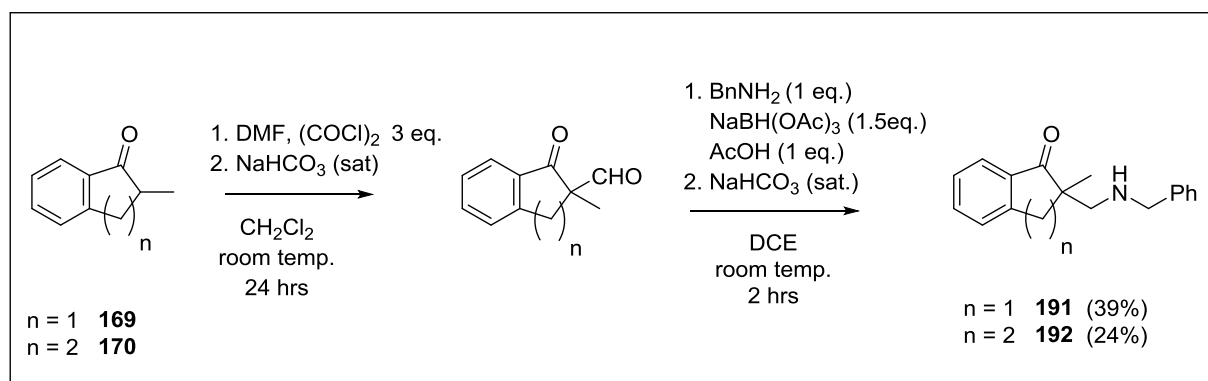

Scheme 88 α -Formylation and subsequent reductive amination of 2-methyl-1-indanone and 2-methyl-1-tetralone.

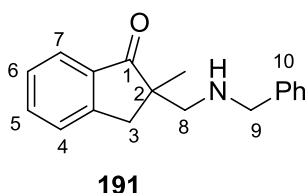

Figure 22

^1H NMR analysis of the product **191** gave a 3H singlet at δ 1.12 ppm corresponding to the methyl protons. The diastereotopic CH_2 protons at position 8 appeared as a 1H doublet at δ 2.56 ppm, $J = 12$ Hz, and a second 1H doublet at δ 2.87 ppm, $J = 12$ Hz. The diastereotopic CH_2 protons at position 3 appeared as a 1H doublet at δ 2.77 ppm, $J = 17$ Hz, and second 1H

doublet at δ 3.23 ppm, $J = 17$ Hz, and the diastereotopic CH₂ protons at position 9, appeared as a 1H doublet at δ 3.64 ppm, $J = 12$ Hz and a second 1H doublet at δ 3.69 ppm, $J = 12$ Hz. The aromatic signals occurred as follows: those of the benzyl group (position 10) occurred in the region δ 7.13-7.23 ppm. The proton at position 5 appeared as 1H triplet at δ 7.28 ppm, $J = 8$ Hz, the proton at position 4 appeared as a 1H doublet at δ 7.37 ppm, $J = 8$ Hz, the proton at position 6 appeared as a 1H triplet at δ 7.51 ppm, $J = 8$ Hz, and the proton at position 7 appeared as a 1H doublet at δ 7.66 ppm, $J = 8$ Hz. The NH proton appeared as a broad singlet at δ 1.69 ppm. Analysis by IR spectroscopy gave absorptions at 1702 cm⁻¹ corresponding to the carbonyl group and 3329 cm⁻¹ for the NH group. High resolution mass spectrometry (m/z , ES) gave 266.1544 for the molecular ion [MH]⁺; required 266.1539.

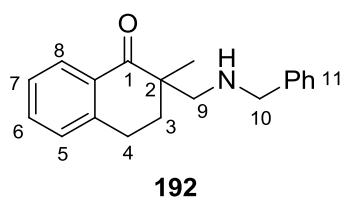

Figure 23

¹H NMR analysis of product **192** gave a 3H singlet at δ 1.19 ppm corresponding to the methyl group and a broad 1H singlet at δ 1.62 ppm corresponding to the NH proton. The CH₂ protons at position 3 gave a 1H multiplet at δ 1.72-1.84 ppm and a 1H double double doublet at δ 2.35 ppm, $J = 15, 10, 5$ Hz. A 2H multiplet was observed at δ 2.82-3.02 ppm corresponding to the CH₂ protons at position 4. The diastereotopic CH₂ protons at position 9 gave a 1H doublet at δ 2.49 ppm, $J = 12$ Hz, and a second 1H doublet at δ 2.95 ppm, $J = 12$ Hz. The diastereotopic CH₂ protons at position 10 occurred as a 1H doublet at δ 3.70 ppm, $J = 12$ Hz, and a second 1H doublet at δ 3.76 ppm, $J = 12$ Hz. The aromatic signals occurred as follows: those of the benzyl group (position 11), and also the protons at positions 5 and 6, occurred as a 7H multiplet in the region δ 7.17-7.39 ppm. The proton at position 7 appeared as a 1H triplet at δ 7.38 ppm, $J = 8$ Hz, and the proton at position 8 appeared as a 1H doublet at δ 8.01 ppm, $J = 8$ Hz. Analysis by IR spectroscopy gave absorptions at 1674 cm⁻¹ corresponding to the carbonyl group and 3334 cm⁻¹ corresponding to the NH group. High resolution mass spectrometry (m/z , ES) gave 280.1698 for the molecular ion [MH]⁺; required 280.1696.

2.16 Summary

In summary, a new and simple method for the preparation of α -formyl- α -substituted ketones, using cheap, commercially available reagents had been discovered. The applicability of the transformation to various substrates had been demonstrated, and conditions had been found which inhibit the tendency of the formylated products to decarbonylate during column chromatography, leading to the isolation of several α -formyl ketones, seven of which were novel compounds. Moreover, it had demonstrated that it was possible to circumvent the purification problem, by converting the α -formyl ketone into a stable aminoketone by a reductive amination, which can potentially be used as building blocks for more complicated systems.

Chapter 3

3 Asymmetric Vilsmeier formylation of α -substituted ketones

3.1 Introduction

The stereoselective synthesis of quaternary carbon centres is a challenging task in organic chemistry.¹¹¹ A quaternary carbon centre is defined to be a carbon attached to four other carbon substituents as opposed to a tertiary carbon, which can be prepared enantioselectively by reactions involving attack by a carbon nucleophile onto a carbon hetero-atom double bond, such as a carbonyl group or an imine.¹¹¹ The difficulty in forming quaternary carbon centres is believed to be due to the large amount of ‘steric crowding’ involved in the creation of a quaternary stereogenic centre, due to hindered environments around the reaction centres. The use of intramolecular reactions is one approach which is used to try to overcome this problem.¹¹¹ Some known methods for the stereoselective construction of quaternary carbon centres will now be discussed briefly.

The alkylation, or acylation of a tertiary enolate equivalent leads to the formation of a quaternary carbon centre. Omura and co-workers have reported the synthesis of (+)-madindoline **195**, in which a quaternary carbon was formed using a remote diastereomeric induction.^{111,112} Lithium diisopropylamide was used to generate the enolate **194** of the methyl ester group of the compound **193**, and the asymmetric induction was due to the formation of a 1,6-lithium chelate which directed the electrophile to attack at the less sterically hindered face of the enolate.¹¹¹

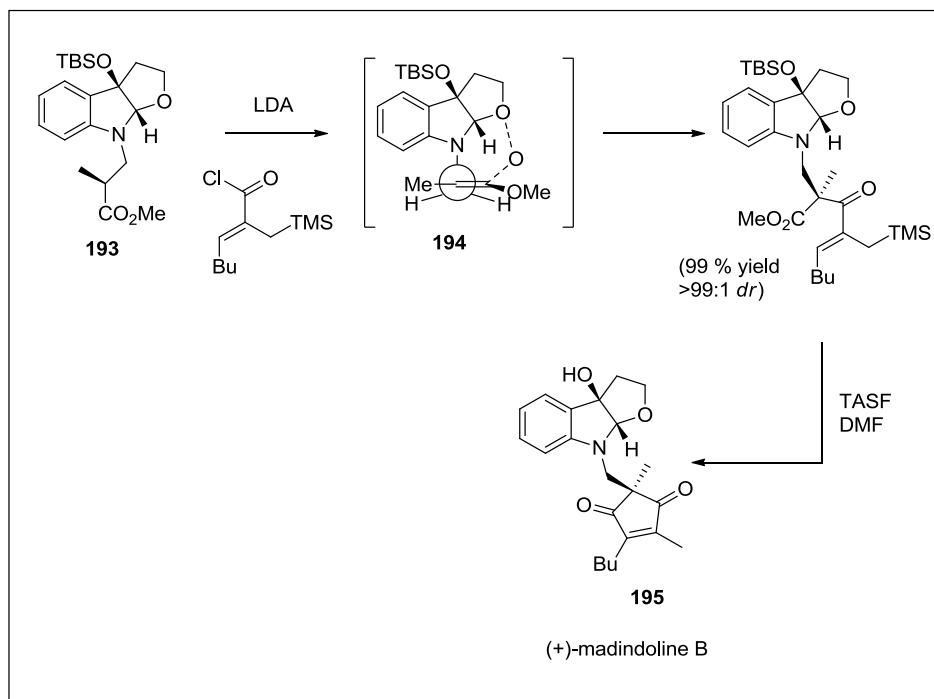

Scheme 89 Remote diastereomeric alkylation in the synthesis of (+)-madindoline.¹¹¹

The use of a chiral auxiliary is a popular choice in the alkylation of enolates to form quaternary carbons, but its introduction and removal require additional steps. In the synthesis of the natural product (-)-herbertenediol **198**, by Meyers, a chiral bicyclic lactam **196** was methylated at the *endo* face to give the desired quaternary carbon with complete stereocontrol.^{111,113} Reduction of the bicyclic lactam followed by hydrolysis gave the cyclopentenone **197**, from which the natural product was obtained in four subsequent steps.¹¹¹

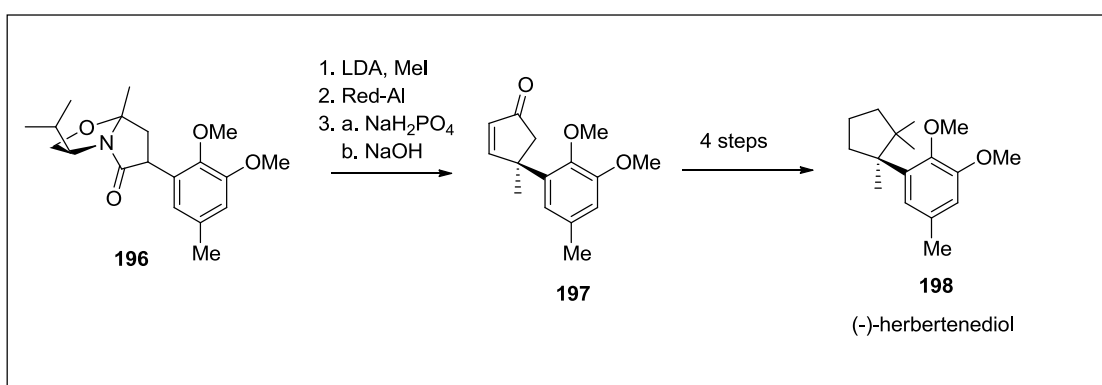

Scheme 90 Asymmetric synthesis of (-)-herbertenediol.¹¹¹

Diels-Alder cycloadditions where the dienophile is an α -substituted enone or enal afford a cycloadduct which contains a quaternary carbon. Rawal and co-workers have reported the enantioselective Diels-Alder reaction between 1-carbamate-1,3-butadiene **199** and various acroleins catalysed by Co(III) salen complex **201**. The reactions were conducted at room temperature with 5 mol% of the catalyst and gave cycloaddition adducts **200** with high enantiomeric excess.^{114,115}

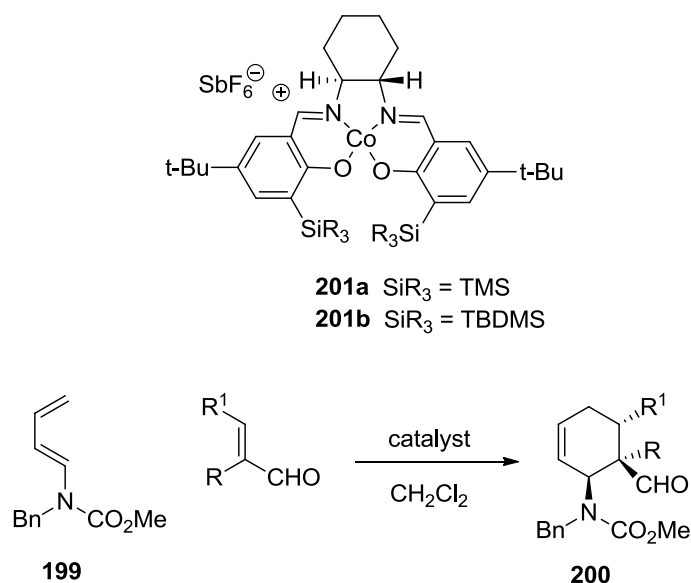

Scheme 91 Enantioselective Diels-Alder reaction between diene **199** and various acroleins.^{114,115}

Table 21 Enantioselective Diels-Alder reaction between diene **199** and various acroleins.^{114,115}

entry	R	R ¹	catalyst	loading (mol %)	time	yield (%)	ee (%)
1	Me	H	201a	5	2 h	93	95
2	Me	H	201b	0.05	3 d	93	98
3	Me	H	201b	0.1	16 h	98	98
4	Et	H	201b	0.1	30 h	93	>97
5	TBSO(CH ₂) ₂	H	201b	0.5	18 h	100	>97
6	-(CH ₂) ₄ -	H	201b	2.0	3 d	78	>95
7	-(CH ₂) ₄ -	H	201b	0.1	20 h	100	98

^a 4Å molecular sieves were used

The authors have explained the observed asymmetric induction based on X-ray crystal structure data where complex **201** was crystallised from an ethanol and water solution containing two equivalents of benzaldehyde. The data indicated that the two benzaldehyde molecules coordinated to the axial positions of the complex, through their carbonyl groups. The benzaldehyde molecules adopted positions which were non-perpendicular to the plane of the complex giving rise to four quadrants, two of which were open *i.e.* those that formed obtuse angles with respect to the plane of the complex. It is believed that a similar arrangement occurs in the case of the coordination of the carbonyl group of the dienophile to complex **201**, and the diene is proposed to attack at the open quadrants in order to minimise steric hindrance caused by the bulky tertiary butyl groups.¹¹⁵

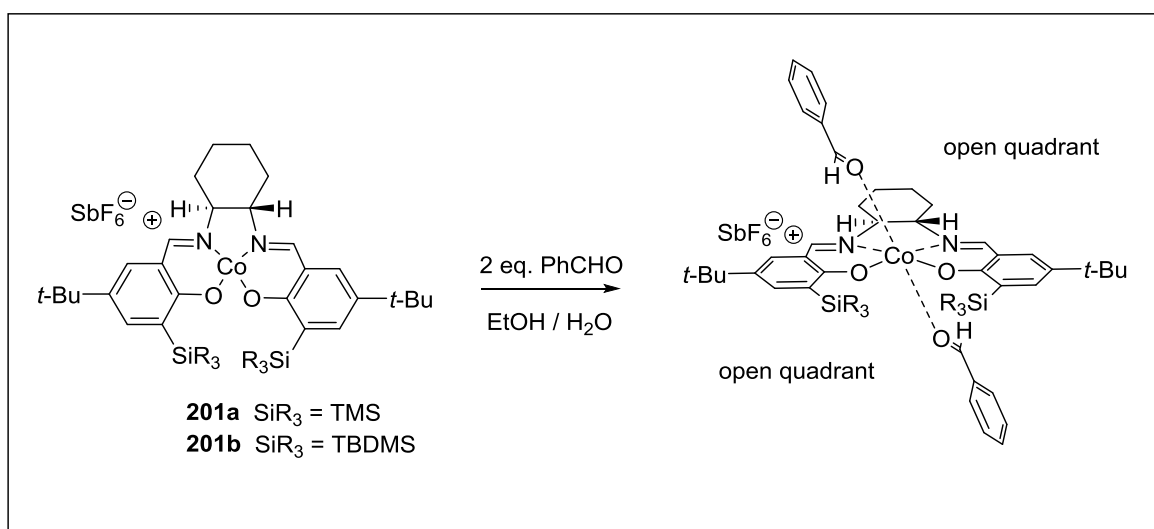

Scheme 92

The Michael addition of carbon nucleophiles to activated olefins is an important and versatile reaction in organic chemistry as a wide range of donors and acceptors can be used.¹¹⁶ The Christoffers group have reported the enantioselective Michael addition of β -keto esters to methyl vinyl ketone with the formation of quaternary carbons, using L-valine diethylamide **204** as a chiral auxiliary, and catalytic quantities of $\text{Cu}(\text{OAc})_2 \cdot \text{H}_2\text{O}$.^{116,117}

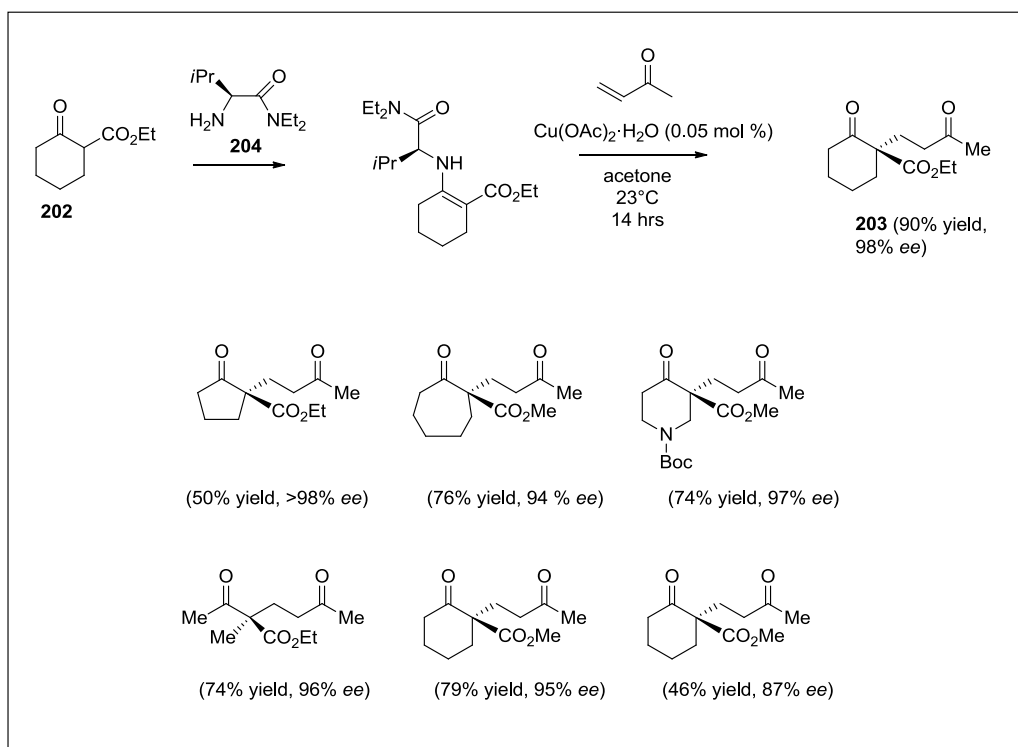

Scheme 93 Cu(II)-catalysed asymmetric Michael reaction with L-valine diethylamide as chiral auxiliary.¹¹⁶

The model in Scheme 94 outlines the mechanism of the asymmetric induction, with keto-ester **202** as the substrate. The auxiliary reacts with the substrate to form an enamine which coordinates to the metal centre of the Cu(II) catalyst as a tridentate ligand through its two carbonyl groups and its NH group (intermediate **205**). The isopropyl group of the auxiliary shields one face of the complex, and therefore coordination of the Michael acceptor occurs at the other face, which gives rise to face selective Michael addition in the subsequent carbon-carbon bonding forming step to afford the product **206**. The auxiliary was easily removed by acidic work up and almost completely recovered.¹¹⁶

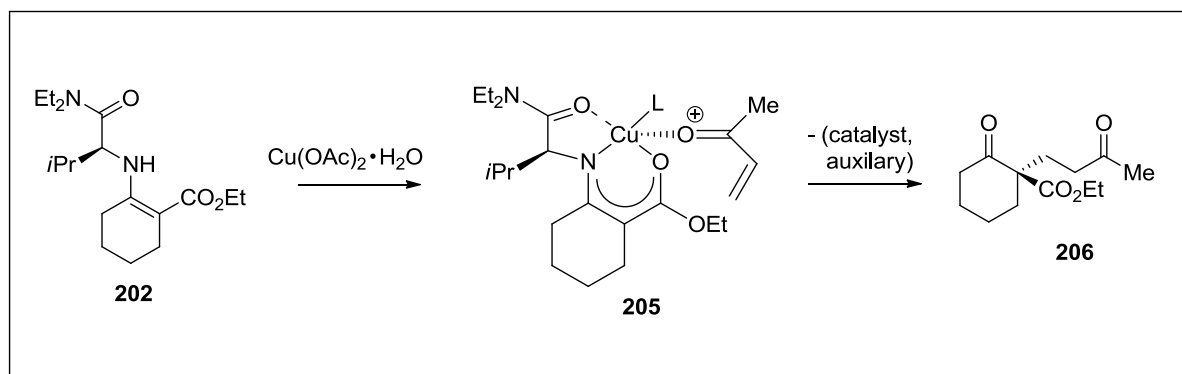

Scheme 94 Mechanism of Cu(II)-catalysed asymmetric Michael reaction with L-valine diethylamide **204** as chiral auxiliary.¹¹⁶

3.2 Model of asymmetric α -formylation using chiral formamides

The last chapter described how a new method had been discovered for the preparation of α -formyl- α -substituted ketones with the formation of a quaternary carbon centre. The remainder of this chapter will describe how research was directed towards extending this methodology to the asymmetric Vilsmeier formylation of α -substituted ketones using chiral chloroiminium salts, derived from chiral formamides, as stoichiometric chiral reagents. The product of the reaction, an α -formyl- α -substituted ketone, contains a stereogenic centre, and therefore two enantiomers of the product are possible. Three chiral formamides, derived from (*S*)-proline, were synthesised for this purpose and their preparation will be described in this chapter.

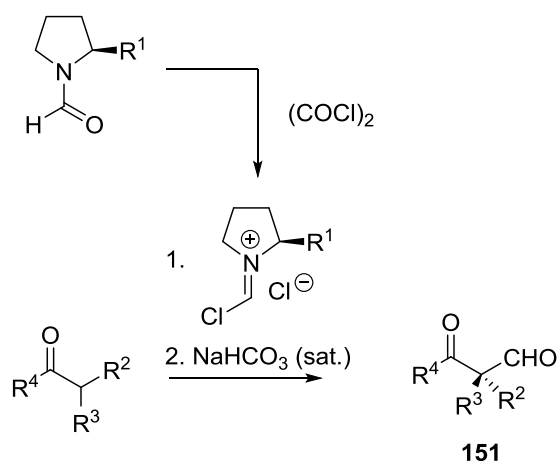

Scheme 95 Proposed asymmetric α -formylation of ketones with chiral chloroiminium salts.

It was predicted that the presence of the sterically large R group projecting out of one face of the chloroiminium salt would have two effects (Figure 24). Firstly, it would cause the iminium salt to adopt the *E* geometry in order to avoid non-bonding interactions between the chloride substituent and the bulky R group. Secondly, it would hinder attack by the enol substrate at this face of the iminium salt.

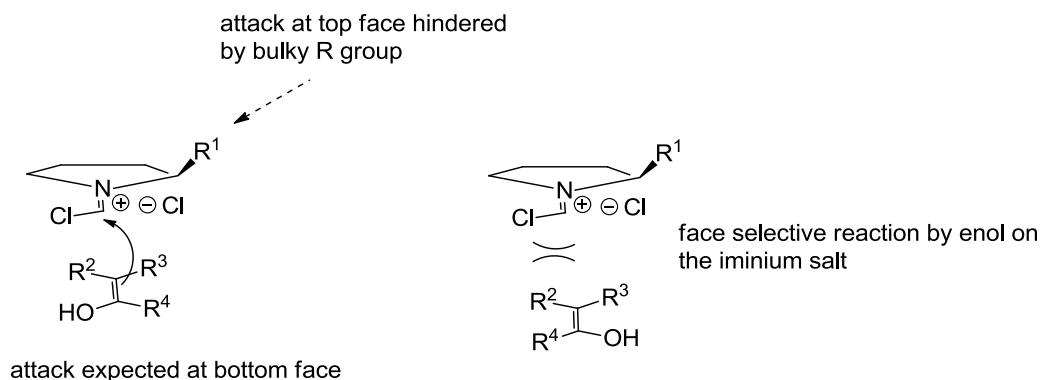
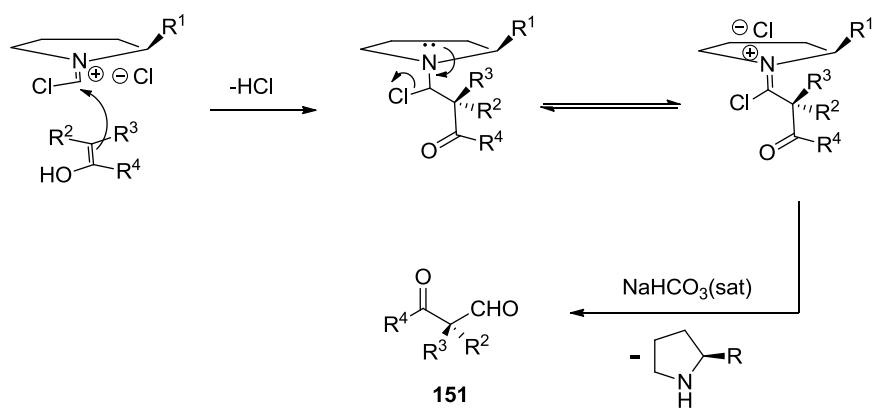

Figure 24 Proposed model of the stereoselectivity in the asymmetric α -formylation of ketones with chiral chloroiminium salts.

Attack by the enol was predicted to occur at the less hindered face of the iminium salt, with the enol reacting preferentially at only one of its two enantiotopic faces. If the prediction was correct the α -formyl ketone product obtained (after hydrolysis) would consist predominantly of enantiomer **151**. In Figure 24 the cyclic backbone of the chloroiminium salt has been depicted as planar for clarity.



Scheme 96 Proposed model of the stereoselectivity in the asymmetric α -acylation of ketones with chiral chloroiminium salts.

Chiral formamides **149**, **207** and **208** were prepared from (*S*)-proline, to be used as chiral Vilsmeier reagents in an asymmetric α -acylation, and their syntheses will now be described.

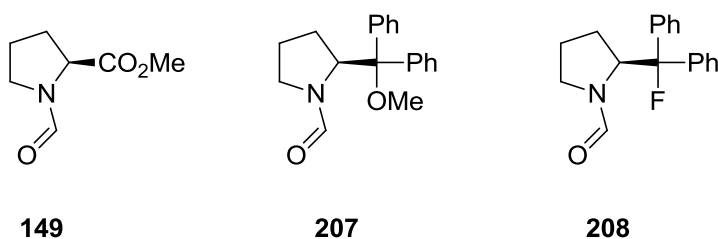
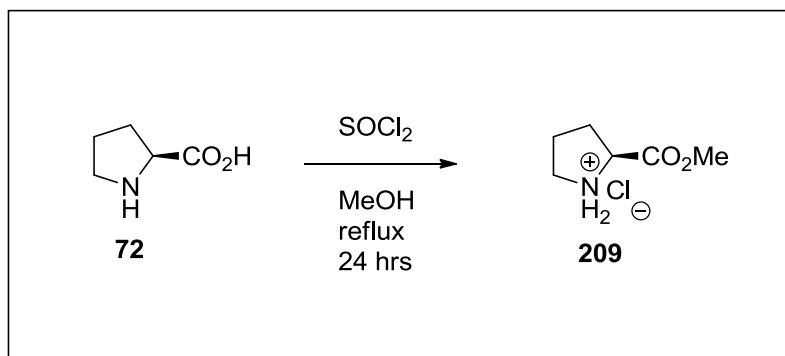

Figure 25

3.3 Preparation of *N*-formyl-(*S*)-proline methyl ester **149**.

(*S*)-Proline **72** was dissolved in methanol and the solution cooled to 0°C in an ice bath. Then thionyl chloride was added dropwise, and the solution stirred for 10 mins. The reaction mixture was then heated at reflux for 24 hrs. The solvent and excess thionyl chloride were then removed *in vacuo*, to give (*S*)-proline methyl ester hydrochloride **209**.



Scheme 97 Preparation of (*S*)-proline methyl ester hydrochloride.¹¹⁸

Attempts to isolate (*S*)-proline methyl ester from the hydrochloride **209** by work up with aqueous base were unsuccessful. The material remained mostly in the aqueous phase and only a small amount was isolated from the organic layer. This problem was solved by avoiding the aqueous base work up altogether.

Instead, the hydrochloride was dissolved in dichloromethane and to the solution was added 1 equivalent of triethylamine, to deprotonate at nitrogen thereby generating the free base. The solvent was then removed *in vacuo*, and the solid residue dissolved in formic acid. The solution was then cooled to 0°C in an ice bath, and acetic anhydride was added, and the reaction mixture stirred for 1 hour. The solvent was then removed *in vacuo*, followed by work up with aqueous base (NaHCO₃). An analytical sample was distilled at low pressure, using a Kugelrohr apparatus, to afford the pure product as a colourless oil (81% isolated yield).

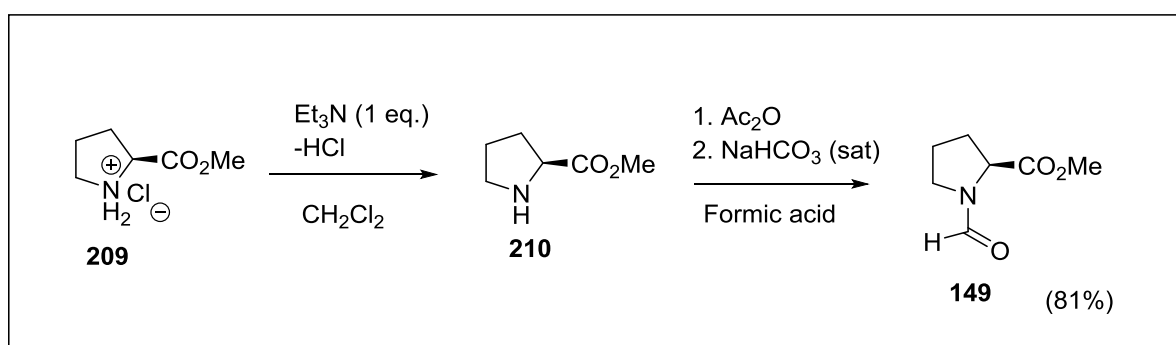

Scheme 98 Preparation of *N*-formyl-(*S*)-proline methyl ester **149**.¹¹⁸

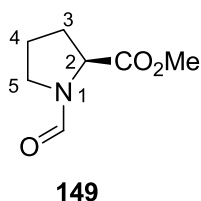

Figure 26

^1H NMR analysis of product **149** gave a 3H multiplet at δ 1.76-1.93 ppm and a 1H multiplet at δ 2.03-2.17 ppm, corresponding to the two sets of CH_2 protons at positions 3 and 4, a 2H multiplet at δ 3.35-3.56 ppm corresponding to the CH_2 protons at position 5, a split singlet was observed at δ 3.58 ppm (0.6H) and at δ 3.61 ppm (0.4H) corresponding to the protons of the methyl group. The proton attached to the stereogenic centre appeared as a double double doublet at δ 4.30 ppm, $J = 16, 8, 4$ Hz, and the formamide proton appeared as a split singlet at δ 8.08 ppm (0.4H) and δ 8.12 ppm (0.6). The formamide and methyl protons appeared as split singlets due to the fact that the molecule exists as two rotamers *i.e.* two conformational isomers which interconvert by rotation about the bond between the nitrogen atom and the formyl carbon atom. Analysis by IR spectroscopy gave absorptions at 1731 cm^{-1} and 1652 cm^{-1} corresponding to the formamide and ester carbonyl bonds respectively. High resolution mass spectrometry (m/z , ES) gave 158.0809 for the molecular ion $[\text{MH}]^+$; required 158.0812.

A ^1H NMR spectrum was taken, in deuterated chloroform, of the chloroiminium salt **150** (derived from the reaction of *N*-formyl-(*S*)-proline methyl ester and oxalyl chloride) and is shown in Appendix 1. It was prepared by dissolving *N*-formyl-(*S*)-proline methyl ester in deuterated chloroform, at 0°C , followed by addition of one equivalent of oxalyl chloride, and the solution stirred for an hour at room temperature, followed by analysis by ^1H NMR spectroscopy.

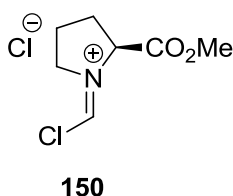
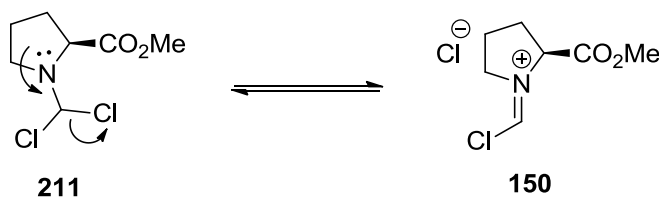

Figure 27

The ^1H NMR spectrum obtained (Appendix 1) indicates that a single conformer is present in the solution, and to a certain extent supported the hypothesis that the iminium salt adopts the *E* geometry. If both the *E* and the *Z* iminium salts had been present in the solution, then the ^1H NMR spectrum would have been more complicated. For instance, there would have been two signals corresponding to the proton attached to the stereogenic centre (at slightly different chemical shifts) and also two signals for the methyl group, whereas in both cases only a single signal is observed. All of the signals were shifted downfield (relative to formamide **149**) due to the presence of the strongly electron withdrawing iminium group. The proton attached to the stereogenic centre appeared as a double doublet at δ 5.65 ppm, $J = 8, 4$ Hz.

One other possibility is that the reactive species is not the chloroiminium salt **150** as depicted above, but rather methyl 1-(dichloromethyl)prolinatate **211**, which may form a certain amount of the chloroiminium salt **150** in equilibrium, although as far as we are aware, this is not a process which has been reported in the literature.



Scheme 99

Work was directed towards the synthesis of chiral formamide **207**, also derived from (*S*)-proline, which contained a much larger substituent on the pyrrolidine ring, than the methyl ester group of formamide **149**. The first attempt to synthesise this compound is described below.

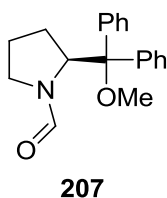
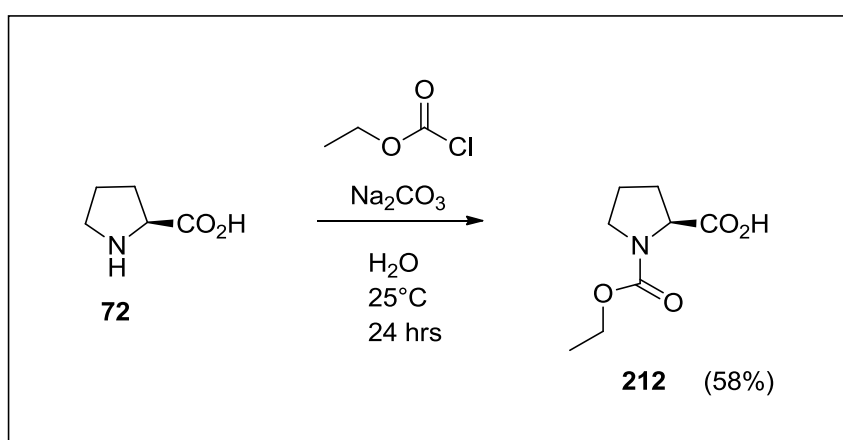

Figure 28

3.4 Attempted synthesis of 2-[methoxy(diphenyl)methyl]pyrrolidine-1-carbaldehyde 207

Protection at the nitrogen of (*S*)-proline was necessary before any chemistry could be performed on the ester group, and it was protected as a carbamate using ethyl chloroformate (because it was available in the laboratory) and the reaction was conducted as follows: (*S*)-proline was dissolved in water and to the solution was added sodium bicarbonate (1.eq.) followed by ethyl chloroformate (1 eq.) and the reaction mixture stirred at 25°C for 24 hours. Following work up, ¹H NMR analysis of the crude product indicated that it was pure enough to be used for the next step without further purification (58% isolated yield).



Scheme 100 Preparation of 1-(ethoxycarbonyl)-L-proline **212**.

This was followed by esterification of the carboxylic acid group, using thionyl chloride in methanol to give the methyl ester **213**, and the reaction was conducted as follows: (*S*)-proline-*N*-ethyl carbamate **212** was dissolved in dry methanol and to the solution was added thionyl chloride 1.5 eq., slowly, and the reaction mixture stirred at 25°C for 8 hrs. Removal of the solvent gave the product as a yellow oil (88% isolated yield). ¹H NMR analysis indicated that it was pure enough to be used for the next step without further purification.

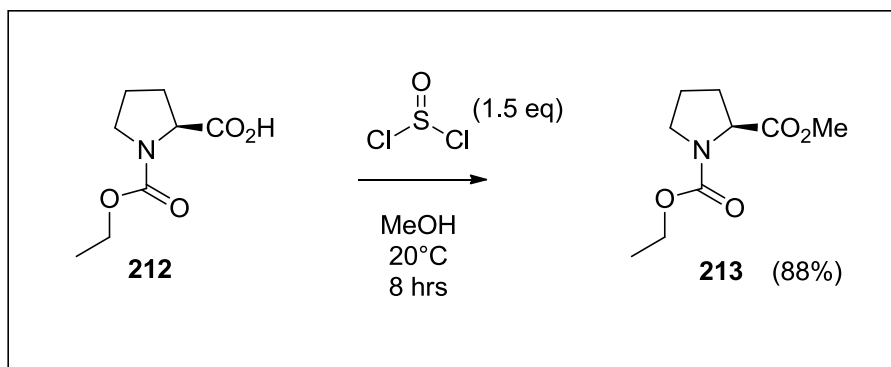

Scheme 101 Preparation of 1-ethyl 2-methyl-(2*S*)-pyrrolidine-1,2-dicarboxylate **213**.

Next, a double Grignard addition across the ester carbonyl group was performed to give product **214**. The Grignard reagent was prepared *in situ* from magnesium and bromobenzene, and 2.5 equivalents of the reagent were used because the insertion of two phenyl groups was required. Following aqueous work up, the residue was purified by column chromatography (hexane/ethyl acetate 2:1) to give the desired compound as a white crystalline solid (28% isolated yield) a significant amount of the product may have been lost during the work up stage.

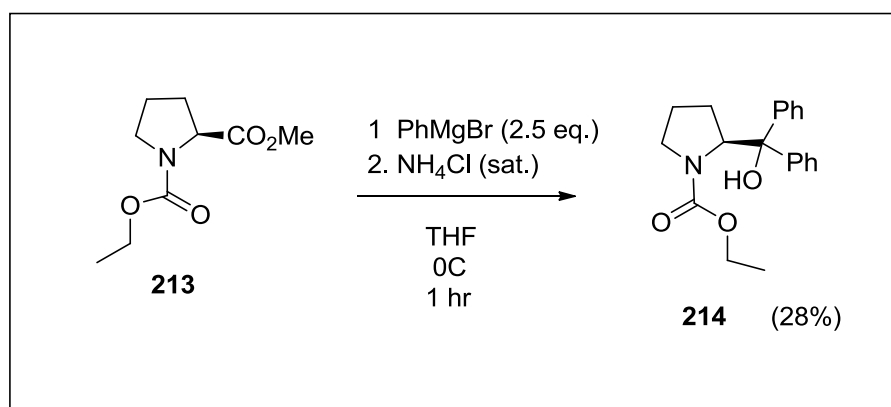

Scheme 102 Preparation of ethyl-(2*S*)-[hydroxy(diphenyl)methyl]pyrrolidine-1-carboxylate **214**.

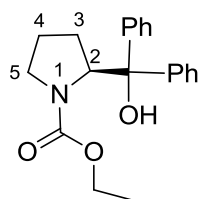

214

Figure 29

^1H NMR analysis of product **214** gave a 3H triplet at δ 1.20 ppm, $J = 8$ Hz, and a 2H quartet at δ 4.11 ppm, $J = 8$ Hz, corresponding to the methyl and methylene protons, respectively, of the carbamate group. The CH_2 protons at position 4, appeared as a 1H multiplet at δ 0.68-0.84 ppm and a 1H multiplet at δ 1.41-1.51 ppm. The CH_2 protons at position 3 appeared as a 1H multiplet at δ 1.83-1.97 ppm and another 1H multiplet at δ 2.01-2.16 ppm. The CH_2 protons at position 5 appeared as a 1H multiplet at δ 2.81-2.96 ppm and a 1H multiplet at δ 3.32-3.41 ppm. The proton attached to the stereogenic centre occurred as double doublet at δ 4.88 ppm, $J = 8, 4$ Hz. The aromatic protons occurred in the region δ 7.18-7.40 ppm. The OH proton appeared as a broad singlet at δ 1.52 ppm. This data was in agreement with that reported in the literature for this compound.¹¹⁹

The next step required methylation of the hydroxyl group and was attempted as follows: Compound **214** was dissolved in dry tetrahydrofuran, under nitrogen, and to the solution was added sodium hydride (1 eq.) and the reaction mixture stirred for 1 hour at room temperature. Then methyl iodide (1 eq.) was added and the reaction mixture stirred at room temperature for 24 hours, followed by aqueous work up. ^1H NMR analysis of the unpurified material, indicated that it contained an approximately 50:50 mixture of the starting material **214** and a side product whose spectral data indicated that it was oxazolodinone **215**.¹²⁰

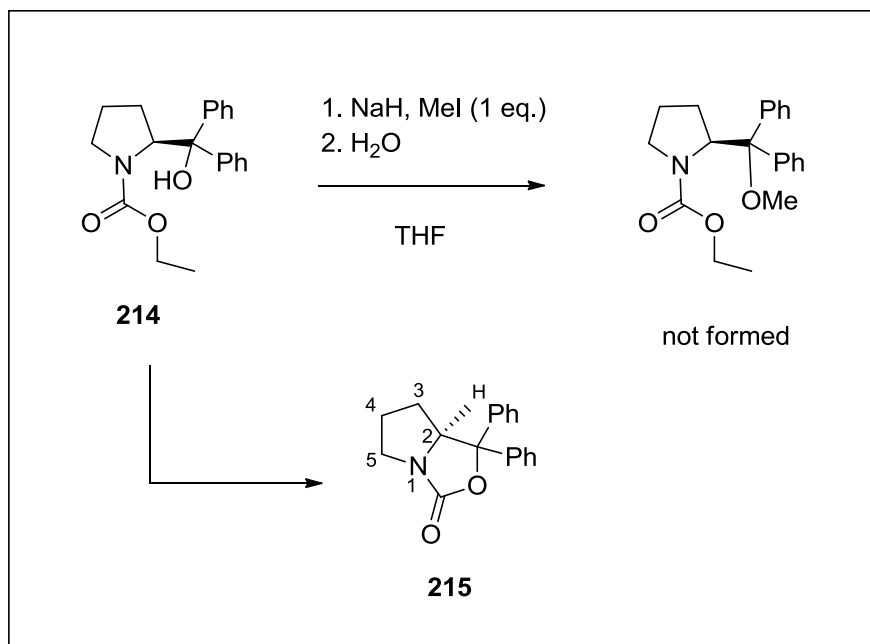

Scheme 103 Attempted synthesis of ethyl (2*S*)-2-[methoxy(diphenyl)methyl]pyrrolidine-1-carboxylate.

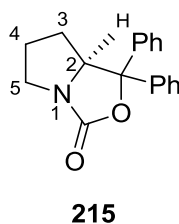
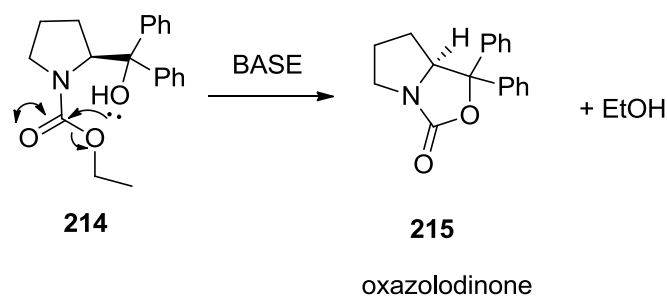

Figure 30

The ^1H NMR analysis of compound **215** gave two 1H multiplets at δ 1.01-1.18 ppm and δ 1.61-1.69 ppm corresponding to the CH_2 protons at position 4, a 2H multiplet at δ 1.90-2.07 ppm corresponding to the CH_2 protons at position 3, a 1H multiplet at δ 3.17-3.22 ppm and another 1H multiplet at δ 3.62-3.70 ppm both corresponding to the CH_2 protons position 5, and a 1H double doublet at δ 4.46 ppm, $J = 8, 5$ Hz, corresponding to the proton at the stereogenic centre (position 2). The aromatic protons appeared in the region δ 7.11-7.48 ppm. This data was in agreement with that reported in the literature for this compound.¹²⁰ Evidently under the basic conditions used for the methylation step an intramolecular cyclisation had occurred to form the oxazolodine **215**, and recovery of the starting material from the crude mixture by chromatography was difficult.



Scheme 104 Proposed mechanism of formation of oxazolodinone **215**.

In an attempt to circumvent this, a direct transformation from the carbamate to the formamide was attempted using diisobutyl aluminium hydride (DIBAL). This reagent reduces esters to an aldehyde, *via* a tetrahedral intermediate (Scheme 105) which is hydrolysed by aqueous acid to give the corresponding aldehyde. This would have been advantageous in that it would have led directly to the corresponding formamide with just methylation of the OH group remaining in order to complete the synthesis. Product **214** was dissolved in dichloromethane and to the solution was added 1 equivalent of DIBAL and the solution stirred at room temperature for 1 hour, followed by work up with aqueous acid.

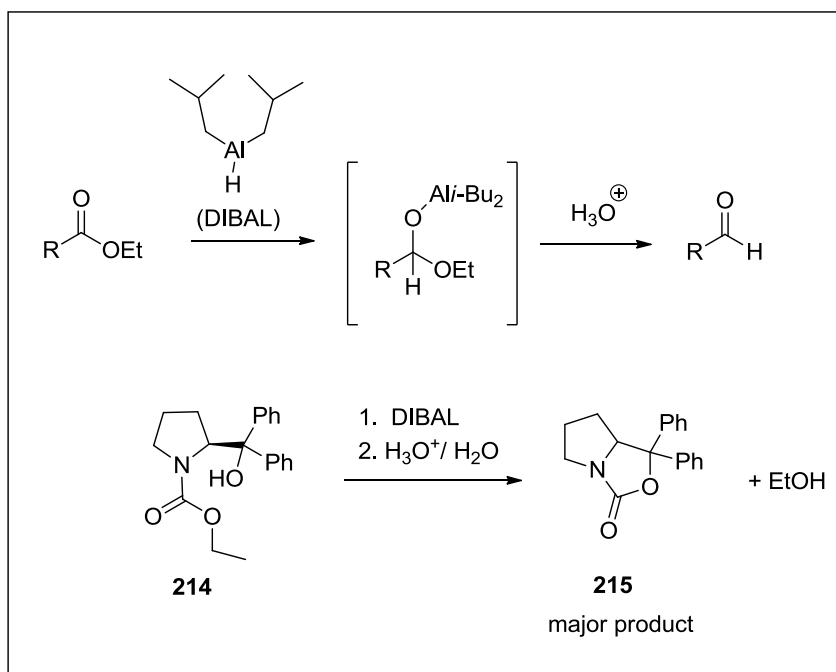

Scheme 105 Attempted DIBAL reduction of product **214**.

However, the material isolated was found to contain the oxazolidinone **215** as the major product, and the problem of intramolecular cyclisation had not been avoided. Therefore attention was directed towards developing a synthesis route whereby formamide **207** and other derivatives could be prepared without oxazolidinone formation. With hindsight it was inevitable that the reaction would lead to intramolecular cyclisation to give the oxazolidinone **215** because of a phenomenon known as the ‘Thorpe-Ingold Effect’.¹²¹ This effect arises due to mutual repulsion between the phenyl groups in compound **214**, which causes the adjacent angle, in between the chiral centre and the hydroxyl group, to be compressed somewhat (as illustrated in Figure 31). This brings the hydroxyl group into closer proximity to the electrophilic carbonyl bond of the carbamate group thereby facilitating intramolecular cyclisation. There may also be an entropic contribution. The process of intramolecular cyclisation involves a decrease in entropy at the transition state (because it is more ordered than the starting material). However, the presence of the phenyl groups restricts the number of conformations that molecule **214** can adopt, thereby reducing its entropy. Moreover, some of those conformations will resemble that of the transition state, and this makes ΔS^\ddagger (the entropy of activation) less negative on going from the starting material to the transition state and thereby facilitates the cyclisation process.¹²¹

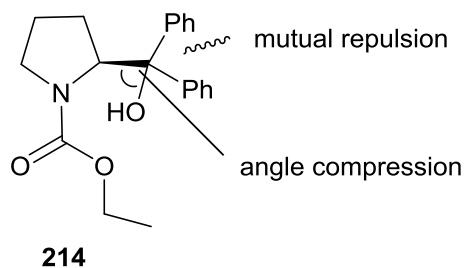

Figure 31

Evidently one of the problems in the synthesis was that the *N*-protecting group contained a good leaving group, so that in the presence of base, the hydroxyl group readily attacked the carbamate carbonyl bond to give the oxazolidinone with the expulsion of ethanol. This suggested that a way to circumvent the problem might be to employ a protecting group on the nitrogen that did not contain such a leaving group. It was decided to use a benzyl group to protect the nitrogen, and a literature protocol was found for this,¹²² though there were concerns

about the ease of its subsequent removal. The modified method used to synthesise formamide **207** is described below.

3.5 Preparation of methyl (*S*)-1-benzylpyrrolidine-2-carboxylate **216**.

(*S*)-Proline was dissolved in methanol and to the solution was added thionyl chloride, and the mixture heated at reflux for 24 hours. The solvent and excess thionyl chloride were then removed *in vacuo*. The hydrochloride salt was heated at reflux in a mixture of benzyl bromide (1.1 eq.) and triethylamine (5 eq.), in toluene for 24 hours, followed by work up with aqueous base. The isolated material was pure enough to use in the next step without the need for further purification (84% isolated yield).

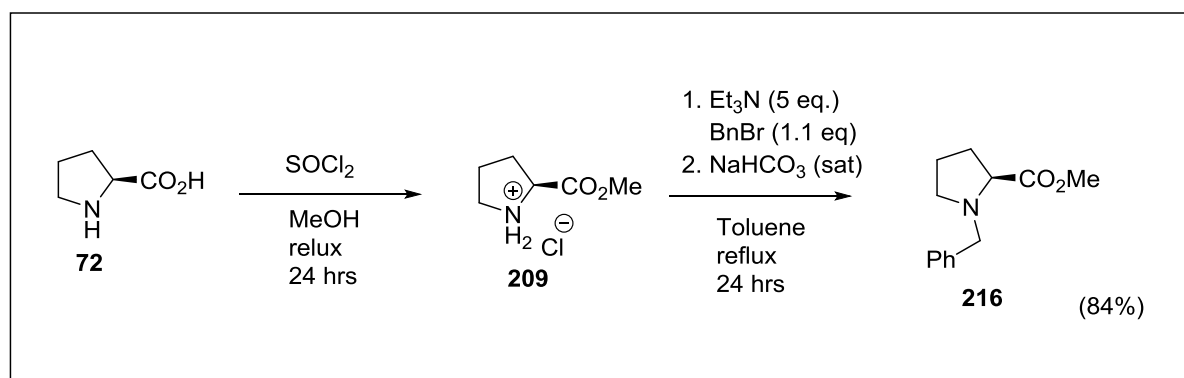

Scheme 106 Preparation of methyl 1-benzyl-(*S*)-prolinate **216**.¹²²

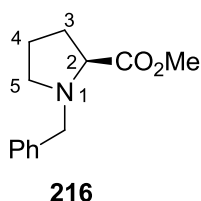

Figure 32

^1H NMR analysis of product **216** gave the following data: the CH_2 protons at positions 3 and 4 appeared as multiplets at δ 1.66-1.75 ppm (1H), δ 1.80-1.93 ppm (2H) and δ 2.02-2.13 ppm (1H). The CH_2 protons at position 5 appeared as a 1H multiplet at δ 2.27-2.39 ppm and another 1H multiplet at δ 2.96-3.02 ppm. The proton attached to the stereogenic centre appeared as a double doublet at δ 3.19 ppm, $J = 8, 4$ Hz. The benzyl CH_2 protons appeared as a 1H doublet at

δ 3.51 ppm, $J = 16$ Hz, and a 1H doublet at δ 3.83 ppm, $J = 16$ Hz. The methyl protons appeared as a 3H singlet at δ 3.59 ppm, and the aromatic protons appeared in the region δ 7.18-7.28 ppm. Analysis by IR spectroscopy gave an absorption at 1735 cm^{-1} for the carbonyl bond. High resolution mass spectrometry (m/z , ES) gave 220.1331 for the molecular ion $[\text{MH}]^+$; required 220.1332. This data was in agreement with that reported in the literature for this compound.¹²²

3.6 Preparation of (*S*)-(1-benzylpyrrolidin-2-yl)diphenylmethanol **217**.

The next step required the insertion of two phenyl groups, at the ester carbonyl bond, by a Grignard reaction. Phenyl magnesium bromide was prepared *in situ* by adding bromobenzene to a flask containing magnesium turnings, a little iodine (to initiate the reaction) and tetrahydrofuran as solvent. Then the *N*-benzyl protected (*S*)-proline methyl ester **216** was added, at room temperature, and the reaction mixture stirred for 10 mins during which time it refluxed in its own heat. When it had settled it was heated at reflux for a further 2 hours to drive the reaction to completion, followed by work up with aqueous acid. Recrystallisation from ethanol gave the product **217** as a white solid (97% isolated yield).

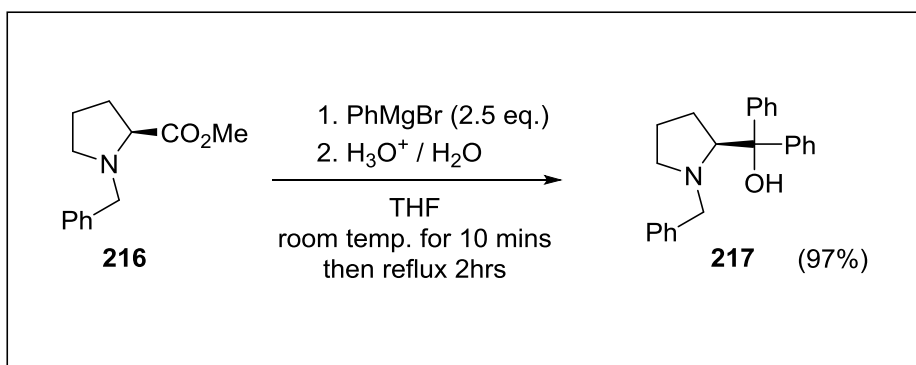

Scheme 107 Preparation of [(*2S*)-1-benzylpyrrolidin-2-yl](diphenyl)methanol **217**.¹²²

The first addition of the Grignard reagent to the ester carbonyl leads to the formation of an alkoxide, and the carbonyl group is then reformed by the expulsion of the best available leaving group, the methoxy substituent. This gives a ketone which is more electrophilic than the starting ester group, and is immediately attacked again by the Grignard reagent to give a second alkoxide ion, which is protonated during the acidic work up to give the desired amino

alcohol. There was some concern that some racemisation could have occurred by deprotonation of the proton attached to the stereogenic centre by the Grignard reagent, which is a strong base, but a specific rotation for the product gave $[\alpha]_D^{22} +64.0$ (*c* 0.01, CHCl₃). This was close enough to the literature value of $[\alpha]_D^{20} +86.6.0$ (*c* 1.0, CHCl₃),¹²² which was reported by Sparr and co-workers, for us to be satisfied that racemisation had not been an issue.

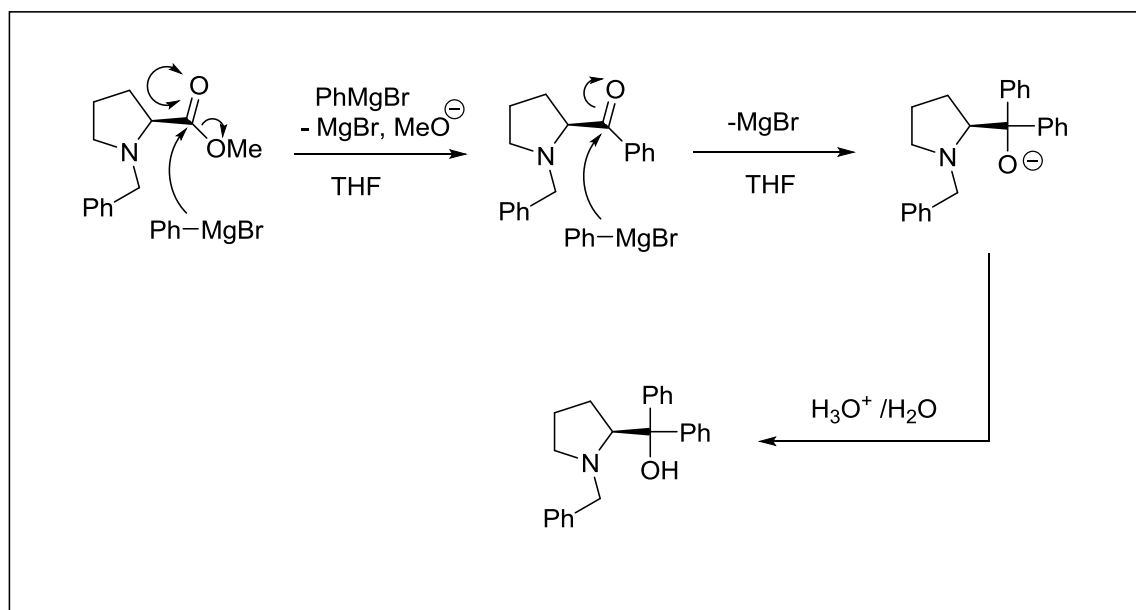

Scheme 108 Mechanism of the Grignard addition in the preparation of [(2*S*)-1-benzylpyrrolidin-2-yl](diphenyl)methanol **217**.

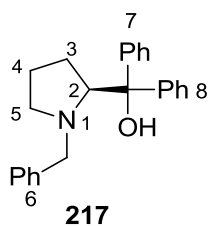

Figure 33

¹H NMR analysis of product **217** gave the following data: the CH₂ protons at positions 3 and 4 appeared as multiplets at δ 1.51-1.62 ppm (2H), δ 1.65-1.73 ppm (1H) and 1.84-1.94 ppm (1H). The CH₂ protons at position 5 appeared as a 1H multiplet at δ 2.24-2.32 ppm and another 1H multiplet at δ 2.81-2.87 ppm. The benzyl CH₂ protons appeared as a 1H doublet at δ 2.95

ppm, $J = 12$ Hz, and a 1H doublet at δ 3.15 ppm, $J = 12$ Hz. The proton attached to the stereogenic centre appeared as a double doublet at δ 3.91 ppm, $J = 12, 4$ Hz, and the OH proton appeared as a broad singlet at δ 4.83 ppm. The *ortho* protons of the phenyl groups at positions 7 and 8 gave doublets at δ 7.51 ppm, $J = 8$ Hz, (2H) and δ 7.65 ppm, $J = 8$ Hz, (2H). The remaining aromatic protons appeared as a multiplet (11H) at δ 6.95-7.24 ppm. Analysis by ^{13}C NMR gave a signal at δ 139.7 ppm corresponding to the *ipso* carbon of the phenyl group at position 6, and signals at δ 148.1 ppm and δ 148.3 ppm for the *ipso* carbons of the phenyl groups at positions 7 and 8. Analysis by IR spectroscopy gave an absorption at 3322 cm^{-1} corresponding to the hydroxyl group. This data was in agreement with that reported in the literature for this compound.¹²²

3.7 Preparation of (*S*)-(-)-1-benzyl-2-(1-methoxy-1,1-diphenylmethyl)-pyrrolidine **218**.

It was now necessary to methylate the hydroxyl group of product **217** in order to prevent it from interfering in subsequent Vilsmeier chemistry and also to prevent oxazolodinone formation. (*S*)-(1-Benzylpyrrolidin-2-yl)diphenylmethanol **217** was dissolved in dry tetrahydrofuran, under argon, and the solution cooled to -30°C . Then methyl iodide and sodium hydride were added and the reaction was allowed to warm to room temperature. The reaction mixture was then heated at reflux for 6 days under argon during which time a grey solid precipitated, followed by a work up with saturated ammonium chloride. The crude material was purified by column chromatography (SiO_2) with 5% EtOAc-hexane to give the product **218** as a pale orange solid (65% isolated yield). The reaction required a long reflux of 6 days, possibly because the tertiary alcohol is so sterically hindered.

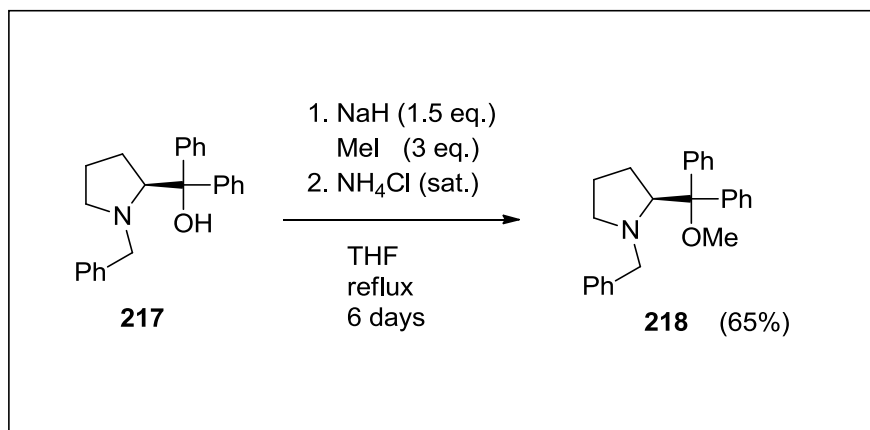

Scheme 109 Preparation of (2*S*)-1-benzyl-2-[methoxy(diphenyl)methyl]pyrrolidine **218**.¹²³

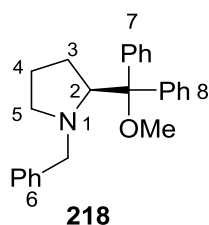

Figure 34

¹H NMR analysis of product **218** gave the following data: the CH₂ protons at positions 3 and 4 appeared as multiplets at δ 0.37-0.49 ppm (1H), δ 1.23-1.44 ppm (1H), δ 1.77-1.84 ppm (1H) and δ 1.96-2.04 ppm (1H). The CH₂ protons at position 5 appeared as a 1H multiplet at δ 2.08-2.25 ppm and another 1H multiplet at δ 2.46-2.58 ppm. The methyl protons appeared as a 3H singlet at δ 2.97 ppm, and the benzyl CH₂ protons appeared as a 1H doublet at δ 3.46 ppm, $J = 16$ Hz, and a 1H doublet at δ 4.26 ppm, $J = 16$ Hz. The proton attached to the stereogenic centre appeared as a double doublet at δ 3.99 ppm, $J = 8, 4$ Hz. The aromatic protons appeared as a multiplet (11H) at δ 7.18-7.41 ppm and another multiplet (4H) at δ 7.64-7.68 ppm. Analysis by ¹³C NMR gave a signal at δ 130.5 ppm corresponding to the *ipso* carbon of the phenyl group at positions 6, and signals at δ 139.5 ppm and δ 140.4 ppm corresponding to the *ipso* carbons of the phenyl groups at positions 7 and 8. This data was in agreement with that reported in the literature for this compound.¹²³

Having made the amino ether **218**, the next step was to remove the benzyl protecting group on the nitrogen. Initially, this was attempted by catalytic hydrogenolysis over palladium (on carbon), however a much better result was achieved by using palladium hydroxide (on carbon) and ammonium formate.¹²⁴ Moreover, the conditions used led to some *N*-formylation of the

debenzylated material, which was a useful by-product since *N*-formylation was the next step in the synthesis. That being the case, it was experimentally more convenient to employ a one pot conversion of the *N*-benzylated compound to the *N*-formylated derivative.

3.8 Preparation of 2-[methoxy(diphenyl)methyl]pyrrolidine-1-carbaldehyde **207**.

(*S*)-(-)-1-Benzyl-2-(1-methoxy-1,1-diphenylmethyl)-pyrrolidine **218** was dissolved in methanol (250 mL) and to the solution was added ammonium formate and 10 mol% palladium hydroxide (on carbon) and the reaction mixture was heated at reflux for 3 days. The reaction was cooled to room temperature, and the solvent removed *in vacuo* to afford a crude material which contained a mixture of (2*S*)-2-[methoxy(diphenyl)methyl]pyrrolidine **219** and its *N*-formylated analog **207**. This mixture was dissolved in formic acid and cooled to 0°C. Then acetic anhydride was added and the reaction mixture was allowed to warm to room temperature with stirring. Work up with aqueous base (NaHCO₃) gave the crude material which was purified by column chromatography (SiO₂) with 10% EtOAc-hexane to give the product as a dark purple oil (78% isolated yield) with an overall yield of 41% (starting from (*S*)-proline).¹²⁴

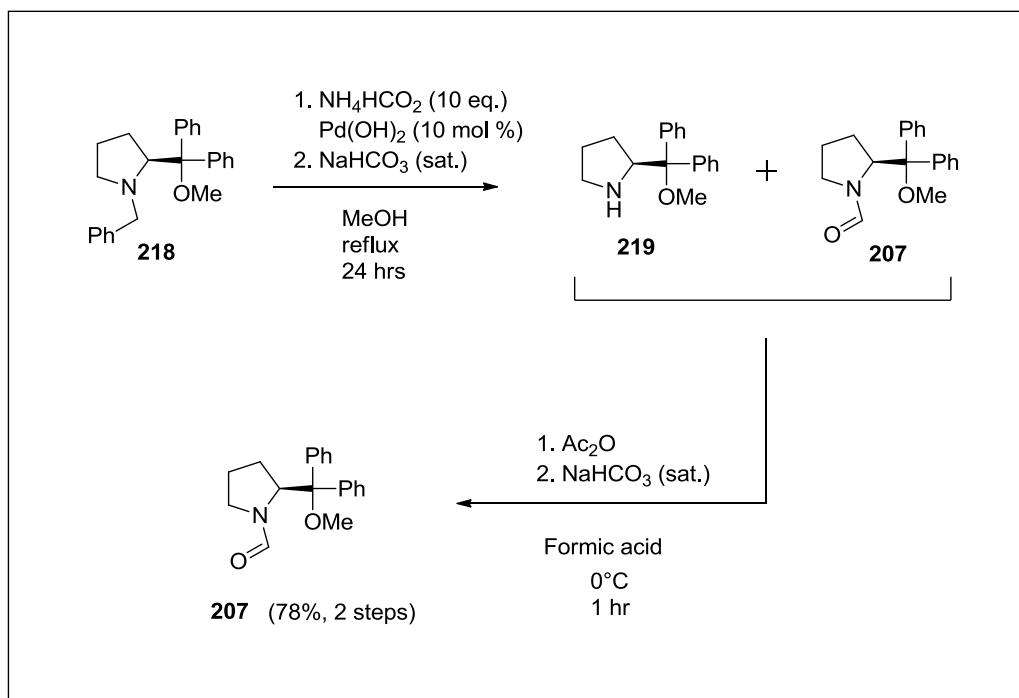

Scheme 110 Preparation of 2-[methoxy(diphenyl)methyl]pyrrolidine-1-carbaldehyde **207**.

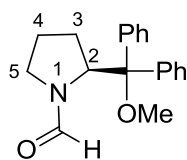

207

Figure 35

^1H NMR analysis of product **207** gave the following data: the CH_2 protons at positions 3 and 4 appeared as multiplets at δ 0.63-0.74 ppm (1H), δ 1.31-1.42 ppm (1H), δ 1.82-1.91 ppm (1H) and δ 2.05-2.16 (2H), this last signal included the signal for one of the protons at position 5, the other proton at that position appeared as a 1H multiplet at δ 3.29-3.38 ppm. The methyl protons appeared as a 3H singlet at δ 2.83 ppm, and the proton attached to the stereogenic centre appeared as a double doublet at δ 4.82 ppm, $J = 8, 4$ Hz. The aromatic protons appeared in the region δ 7.25-7.34 ppm and the formamide proton appeared as a 1H singlet at δ 8.33 ppm. Analysis by ^{13}C NMR gave signals at δ 130.0 ppm and δ 132.5 ppm corresponding to the *ipso* carbons of the phenyl groups and a signal at δ 163.7 ppm corresponding to the formamide carbon. Analysis by IR spectroscopy gave an absorption at 1663 cm^{-1} corresponding to the carbonyl group. High resolution mass spectrometry (m/z , ES) gave 296.1649 for the molecular ion $[\text{MH}]^+$; required 269.1645.

3.9 Preparation of (S)-2-[fluoro(diphenyl)methyl]pyrrolidine-1-carbaldehyde **208**

The literature contained a protocol for the synthesis of (S)-2-(fluorodiphenylmethyl)pyrrolidine **70**.¹²² Sparr and co-workers, who made the compound, used it as an asymmetric epoxidation of *trans*-cinnamaldehydes, and reported that the facial selectivity in the enantio-defining event was aided by a *gauche* effect in the fluorine-iminium ion **71**, as discussed in the introduction.⁵⁰ This effect is caused by a hyperconjugative interaction between the σ bonding orbital of the carbon-hydrogen bond of the stereogenic centre, and the σ^* antibonding orbital of the carbon-fluorine bond.¹²⁵ This acts to keep the two bonds in an anti-periplanar arrangement, with the fluorine substituent situated in a *gauche* position with respect to the carbon-nitrogen bond, with a torsional angle of 57° between the fluorine and nitrogen atoms.⁵⁰ The net effect of this is that

one of the phenyl groups is positioned over the reactive site of iminium ion **71** and thereby enhances the facial selectivity of the reagent.¹²⁵

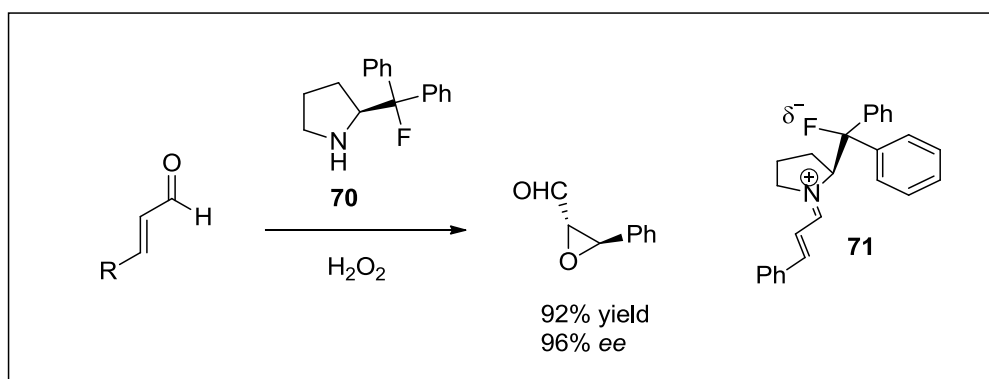

Scheme 111 The ‘*gauche*’ effect in the asymmetric epoxidation of *trans*-cinnamaldehydes using chiral amine **70**.⁵⁰

This compound attracted our interest because it was reasoned that the corresponding formamide **208**, would react with an acid halide, to form chloroiminium salt **220**, which could undergo the same effect, and if so, could influence, and possibly enhance the facial selectivity of the reagent in an asymmetric Vilsmeier formylation.

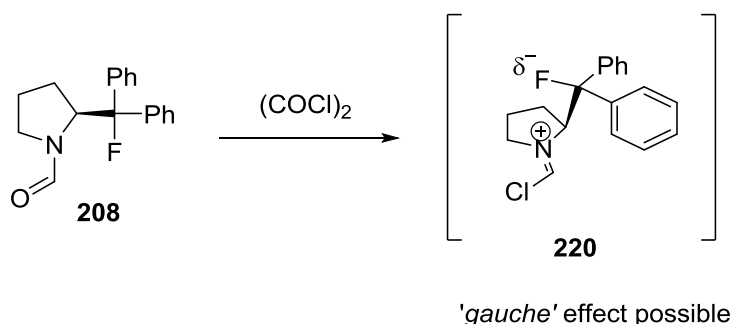

Scheme 112 Potential ‘*gauche*’ effect in chloroiminium salt **220**.

Moreover, it was known that chloroiminium salt formation generates a small quantity of acid, and with formamide **207** this could potentially have lead to some elimination of the methoxy group of **207**, to give compound **222** *via* the formation of the stable carbocation **221**. This may be a reversible process and if it occurred it would have compromised the chiral integrity of the corresponding chloroiminium salt. This was another reason to prepare formamide **208**, where

there is a fluorine substituent at that quaternary carbon instead of a methoxy group, and it was reasoned that elimination of fluoride ion was less likely to occur.

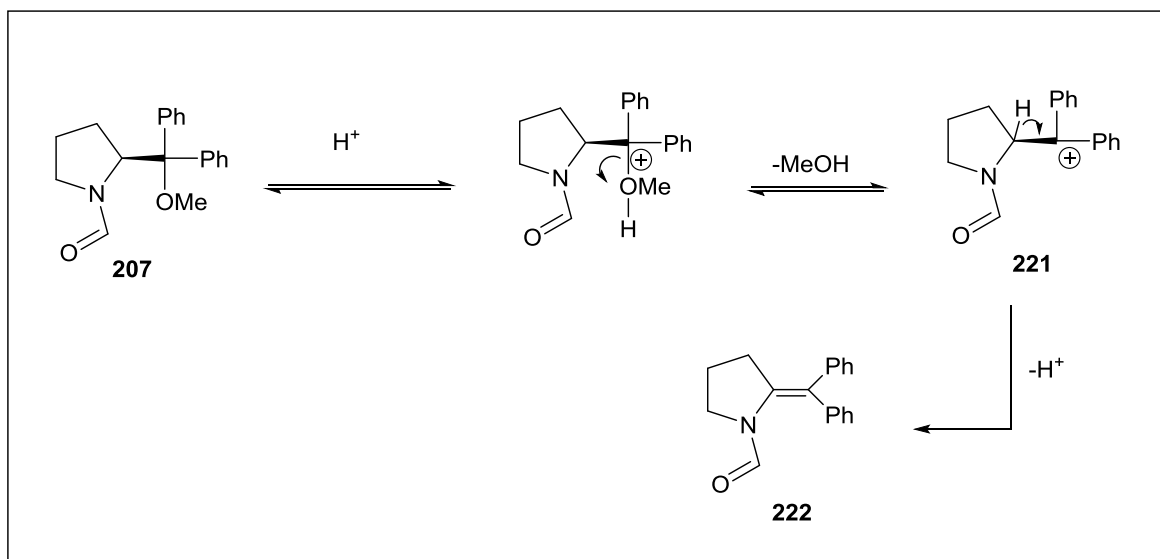

Scheme 113 Potential elimination of methoxy group from formamide **207** in acidic conditions.

Formamide **208** was prepared as follows: (*S*)-diphenyl(pyrrolidin-2-yl)methanol **219** (which was obtained commercially) was dissolved in dichloromethane and the solution was cooled to 0°C . Then diethyl ammonium suflur trifluoride (DAST) was added over a period of 1 min, with stirring, and the solution allowed to warm to room temperature. After work up with aqueous base, the crude material was dissolved in formic acid and cooled to 0°C . Then acetic anhydride was added and the reaction mixture was allowed to warm to room temperature with stirring. Work up with aqueous base gave the crude material which was column chromatographed (SiO_2) with 1:1 EtOAc-hexane to give product **208** as a dark brown oil (54% isolated yield).

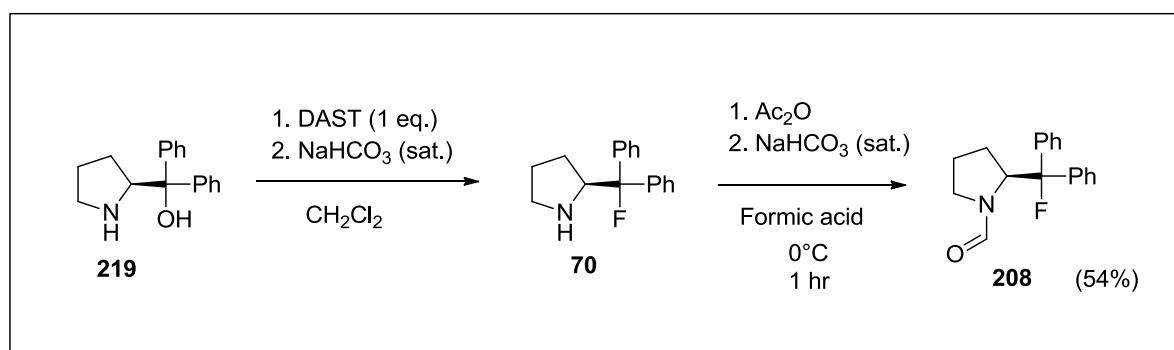

Scheme 114 Preparation of (*S*)-2-[fluoro(diphenyl)methyl]pyrrolidine-1-carbaldehyde **208**.

Although fluorinations using DAST can proceed *via* either an S_N1 or an S_N2 mechanism, in this particular reaction it probably proceeded *via* an S_N1 mechanism due to ability of compound **219** to undergo elimination to form the stable carbocation **223**.¹²⁶

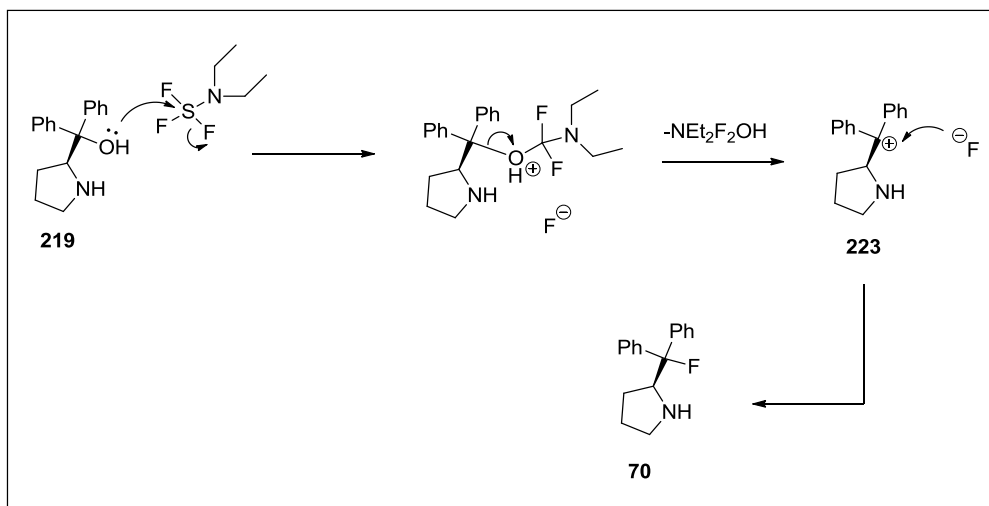

Scheme 115 A mechanism for the fluorination of compound **219** using DAST.¹²⁶

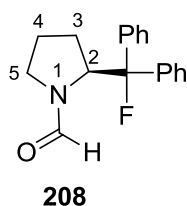

Figure 36

¹H NMR analysis of product **208** gave the following data: the CH₂ protons at positions 3 and 4 appeared as a 2H multiplet at δ 1.65-1.83 ppm, and another 2H multiplet at δ 1.89-2.18 ppm. The CH₂ protons at positions 5 appeared as a 1H multiplet at δ 3.18-3.24 ppm and another 1H multiplet at δ 3.63-3.72 ppm. The proton attached to the stereogenic centre appeared as a double double doublet at δ 4.64 ppm, $J_{\text{H,F}} = 25$ Hz and $J = 8, 4$ Hz. The signal due to this proton is split into a doublet by the fluoride atom, $J = 25$ Hz, and further split into doublets by each of the CH₂ protons at position 3, $J = 8, 4$ Hz. The aromatic protons occurred in the region δ 7.14-7.36 ppm. The formamide proton occurred in the same region as the aromatic signals and was not visible. Analysis by ¹³C NMR gave a signal at δ 140.9 ppm for the *ipso* carbons of the phenyl groups and a signal at δ 163.3 ppm corresponding to the formamide carbon. Analysis by IR spectroscopy gave an absorption at 1655 cm⁻¹ for the carbonyl group.

High resolution mass spectrometry (m/z , ES) gave 284.1445 for the molecular ion $[MH]^+$; required 284.1445.

The optical purity of the chiral formamides **149**, **207** and **208** was determined by taking specific rotation measurements *i.e.* the angle through which they rotated plane-polarized light, and this data is reported in the experimental section.

Having prepared the chiral formamides **149**, **207** and **208**, the next task was to use them in an asymmetric α -formylation of an α -substituted ketone. 2-Methyl-1-indanone and 2-methyl-1-tetralone were chosen as substrates for the asymmetric formylation experiments. They were chosen because they had been found to be reactive substrates in the work that had been done previously, and more importantly, cyclic systems offer a more rigid chiral environment, where rotation round a single bond is not possible, and this makes them ideal substrates for asymmetric reactions.

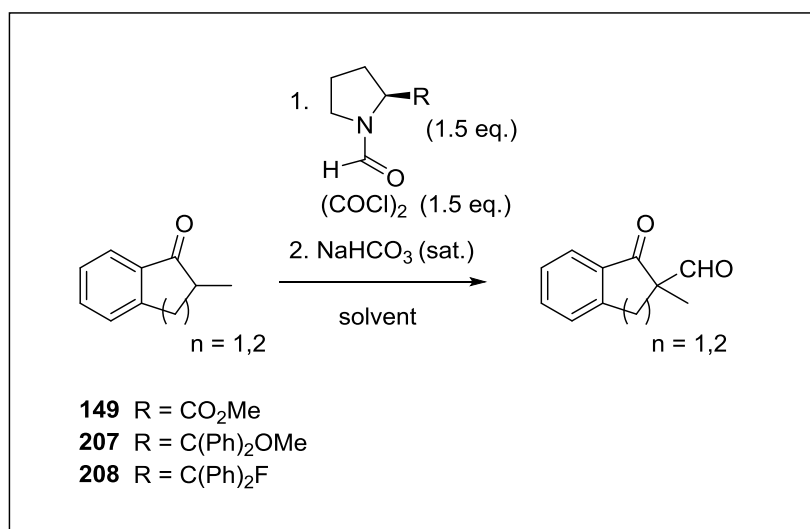

Scheme 116 Asymmetric α -formylation of α -methyl indanone and α -methyl tetralone

3.10 Method used to measure stereoselectivity in asymmetric α -formylation

A method was needed to assay the α -formyl ketones obtained from the asymmetric formylations in order to ascertain whether or not there had been any enantio-enrichment. It was known that the α -formyl ketones had a tendency to decarbonylate during chromatography and therefore this discouraged the use of chiral HPLC as an assaying method, because it may have

led to erroneous results. In any event, a previous attempt had been made to analyse a small amount of the isolated product of the α -formylation of 2-methylcyclohexanone (using the chlorominium salt derived from formamide **149**). When analysed by chiral HPLC (95:5 hexane / isopropyl alcohol) only a single broad peak was observed in the trace, indicating that the material had not been resolved, and this was the case even after the experimental conditions were varied.

It had already been demonstrated that α -formyl ketones can be readily converted into aminoketones by a reductive amination at the aldehyde carbonyl group.¹¹⁰ By using a single enantiomer of a chiral amine, it was possible to reductively aminate the α -formyl ketones **169** and **170** to give two diastereoisomers of the corresponding aminoketones **224** and **225** (Scheme 117). Because they were diastereoisomers, and not enantiomers, they necessarily had different physical properties. (*S*)- α -Methylbenzylamine was used as the chiral amine, and by measuring the ratio of the two diastereoisomeric aminoketones, it was possible to infer the ratio of the two enantiomers of the α -formyl ketone, that had undergone the reductive amination. This was on the assumption that no kinetic resolution had occurred during the reductive amination step itself.

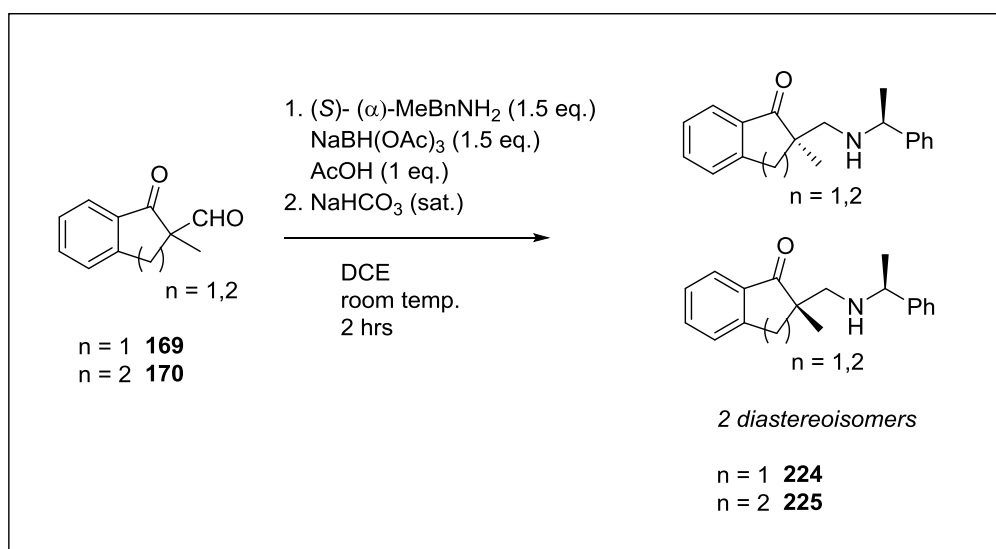

Scheme 117 Reductive aminations of α -formyl ketones **169** and **170**.

3.11 Method for α -formylation and subsequent reductive amination of ketones

The asymmetric formylations and subsequent reductive aminations were performed as follows: the formamide was dissolved in dichloromethane and the solution cooled to 0°C, followed by the addition of oxalyl chloride (1.5 eq.). The ketone (1 eq.) was then added and the reaction stirred at a given temperature and reaction time. Work up with aqueous base (NaHCO₃) gave the crude α -formyl ketones which were redissolved in 1,2-dichloroethane, and to the solution was added (*S*)-(-)- α -methylbenzylamine (1.5 eq.), sodium triacetoxyborohydride (1.5 eq.) and acetic acid (1 eq.) and the solution stirred at room temperature for 2 hours. Work up with aqueous base (NaHCO₃) gave the crude materials which were assayed by ¹H NMR spectroscopy to determine the ratio of two diastereoisomers.

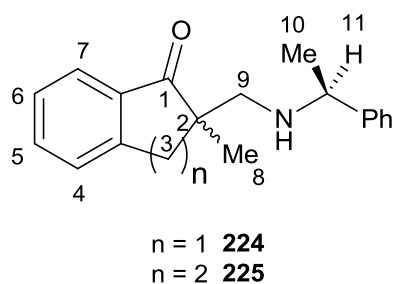

Figure 37

Conveniently, it was found that ¹H NMR analysis of a sample containing a crude mixture of the two diastereoisomers could be used to measure the ratio of the diastereoisomers present, due to the fact that the chemical shifts for the protons in the two diastereoisomers were necessarily different. Most useful for this purpose was integration of the singlets corresponding to the methyl groups α to the carbonyl group *i.e.* at position 8 in Figure 37 above, and also the diastereotopic CH₂ protons at position 9. For the indanone derivative **224** the methyl singlets (at position 8) occurred at δ 1.00 and 1.09 ppm for the two diastereoisomers, and for the tetralone derivative **225** these methyl singlets (position 8) occurred at δ 1.04 and 1.12 ppm. Although the proton and methyl group, at positions 11 and 10 respectively, could theoretically be used to determine the diastereomeric ratio, in practice they were less useful due to the fact that they were often hidden behind other peaks.

As a control reaction, both α -methyl indanone and α -methyl tetralone were reacted with 3 equivalents of $\text{DMF}/(\text{COCl})_2$, using the conditions shown in Tables 22 and 23 (entries 7 and 8 respectively) to give the corresponding α -formyl ketones **169** and **170** respectively, followed by reductive amination with (*S*)-(-)- α -methyl benzylamine (1.5 eq.), sodium triacetoxyborohydride (1.5 eq.) and acetic acid (1 eq.) in the same way as described above, to give aminoketones **224** and **225**. The crude materials were then analysed by ^1H NMR spectroscopy and it was observed that the diastereomeric products were present in an approximately 50:50 ratio within experimental error, which was as expected since the chloroiminium salt derived from $\text{DMF}/(\text{COCl})_2$ is achiral.

Appendix 2 of this thesis shows an expansion of a ^1H NMR spectrum obtained for the product of the formylation and subsequent reductive amination of α -methyl indanone using the conditions described in Scheme 118 (corresponding to the data shown in entry 3 of Table 22). In the major diastereoisomer, one of the diastereotopic CH_2 protons at position 9 (in Figure 37 above) occurred as a 1H doublet at δ 2.47 ppm, $J = 12$ Hz, and in the minor diastereomer, one of the diastereotopic CH_2 protons at this same position occurred as a 1H doublet at δ 2.31 ppm, $J = 12$ Hz. Therefore, by measuring the relative integrals of these two peaks it was possible to measure a diastereomeric ratio as illustrated in Figure 38.

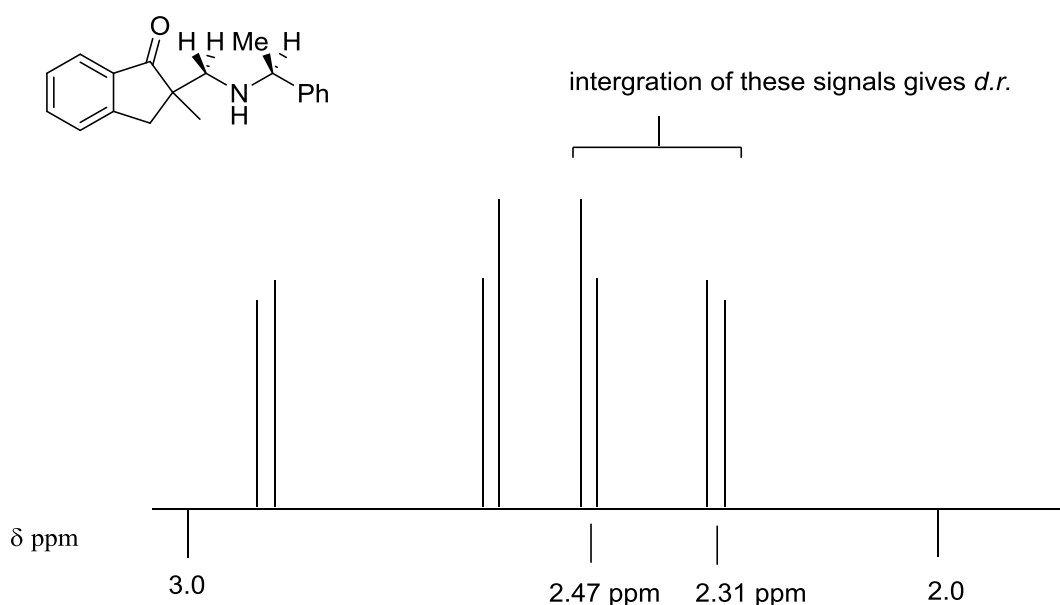
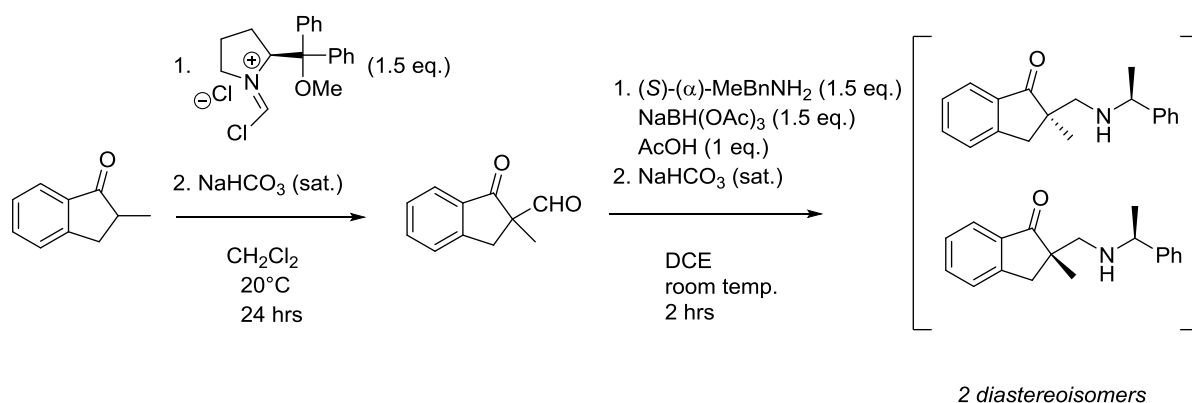

Figure 38



Scheme 118 α -Formylation of α -methyl indanone and subsequent reductive amination of product to give an aminoketone.

The diastereomeric ratio was 65:35 in this particular measurement. Appendix 3 shows an expansion of a ¹H NMR spectrum obtained for the control reaction in which DMF was used as the formamide (entry 7 of Table 22), which shows that these same signals appear in a ratio of 52:48, which is approximately a 1:1 ratio, within experimental error, but these figures give some indication of the margin of error involved in these measurements.

Appendix 4 shows an expansion of a ¹H NMR spectrum obtained for the product of the formylation and subsequent reductive amination of α -methyl tetralone using the conditions described in Scheme 119 (corresponding to the data shown in entry 5 of Table 23). In this spectrum the signals corresponding to the methyl groups at position 8 (in Figure 37 above) were used to measure the diastereomeric ratio which was 63:37 in this measurement. These signals occurred as 3H singlets at δ 1.17 ppm and δ 1.03 ppm, for the major and minor diastereoisomers respectively. Appendix 5 shows an expansion of a ¹H NMR spectrum obtained for the control reaction in which DMF was used as the formamide (corresponding to the data shown in entry 8 of Table 23), which shows that these same signals appear in a ratio of 51:49, which is approximately a 1:1 ratio within experimental error.

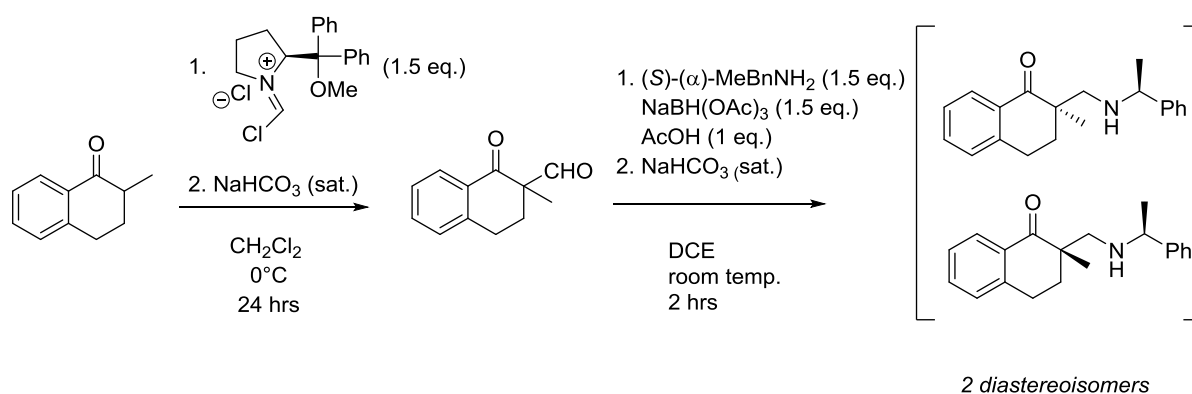

Scheme 119 α -Formylation of α -methyl tetralone and subsequent reductive amination of product to give an aminoketone.

Where possible, the ratios obtained from the integration of the α methyl protons at position 8 (in a particular assay) were compared with the ratios obtained from the integration of the diastereotopic CH_2 protons at position 9 and reasonably good agreement was observed, within experimental error. Using this methodology, a series of asymmetric α -formylations were conducted, under various conditions, using the three prepared formamides **149**, **207** and **208** as stoichiometric chiral reagents, and α -methyl indanone and α -methyl tetralone as substrates. The reactions were performed on a 200 mg scale. The crude α -formyl ketones obtained after aqueous work up were made to undergo the reductive aminations without further purification. Tables 22 and 23 show the results obtained.

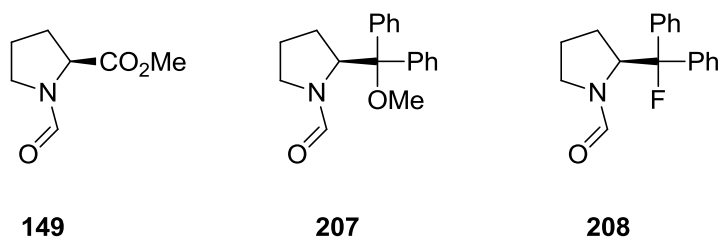
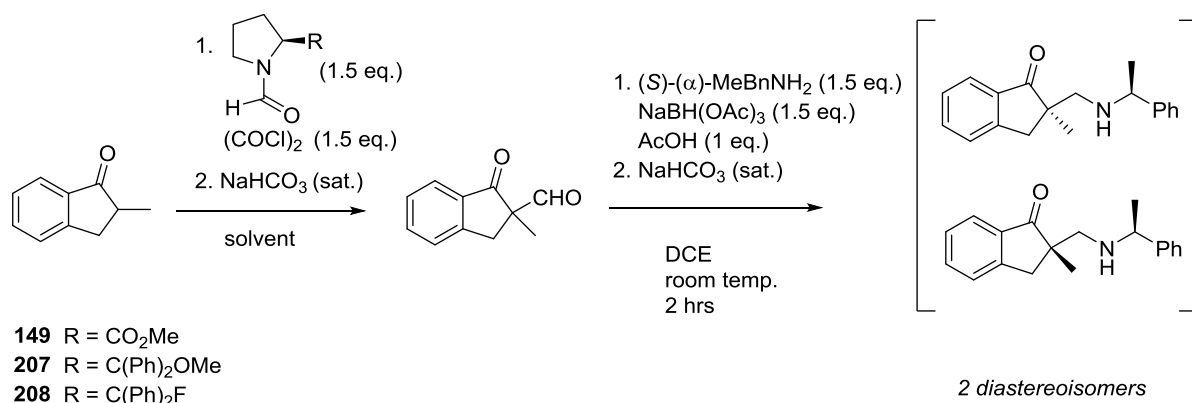

Figure 39 Chiral formamides used in asymmetric α -formylations.



Scheme 120 α -Formylation of α -methyl indanone and subsequent reductive amination of product to give the corresponding aminoketone.

Table 22 α -Formylation of α -methyl indanone and subsequent reductive amination of product to the corresponding aminoketone.

entry	Solvent	formamide	reaction time (hrs)	temp. (°C)	% conversion	<i>d.r.</i>
1	dichloromethane	149	72	20	94	52 : 48
2	dichloromethane	208	72	20	16	71 : 29
3	dichloromethane	207	24	20	53	65 : 35
4	dichloromethane	207	24	0	13	63 : 37
5	dichloromethane	207	3	38	87	70 : 30
6	chloroform	207	3	61	91	71 : 29
7	dichloromethane	DMF	24	20	>99	52 : 48

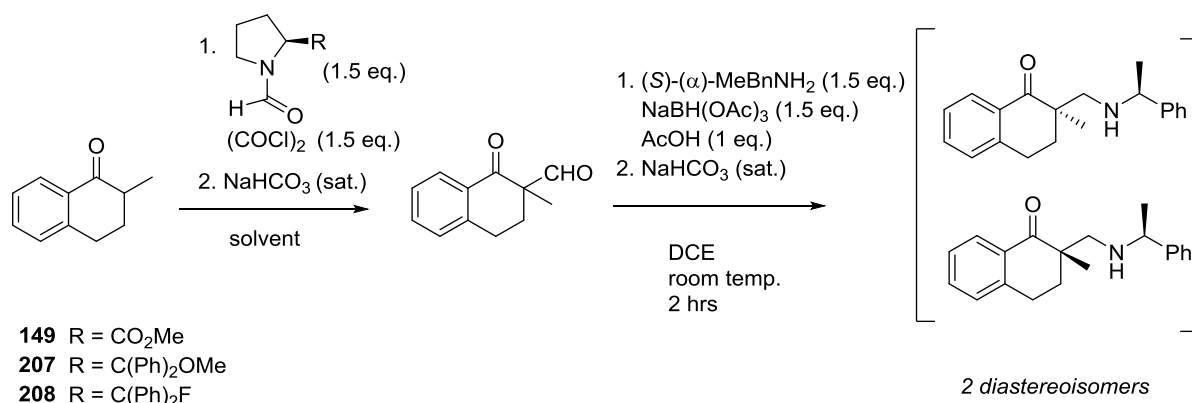

Scheme 121 α -Formylation of α -methyl tetralone and subsequent reductive amination of product to give the corresponding aminoketone.

Table 23 α -Formylation of α -methyl tetralone and subsequent reductive amination of product to give the corresponding aminoketone.

entry	Solvent	formamide	reaction time	temp. (°C)	% conversion	d.r.
1	dichloromethane	149	6 days	20	37	57 : 43
2	dichloromethane	208	10 days	20	26	81 : 19
3	dichloromethane	208	24 hrs	38	14	84 : 16
4	dichloromethane	207	6 days	20	33	67 : 33
5	dichloromethane	207	24 hrs	0	13	63 : 37
6	dichloromethane	207	3 hrs	38	87	70 : 30
7	chloroform	207	3 hrs	61	91	71 : 29
8	dichloromethane	DMF	24 hrs	38	78	51 : 49

In all of the experiments the same major / minor diastereoisomer relationship was observed *i.e.* for the indanone derivative **224** the major diastereoisomer was always the one which gave a signal at δ 1.04 (\pm 0.03) ppm for the methyl protons at position 8, and a 1H doublet at δ 2.47 (\pm 0.03) ppm for one of the diastereotopic CH₂ protons at position 9 (in Figure 37 above), and for the tetralone derivative **225** the major diastereoisomer was always the one whose signal for the methyl protons at position 8 (in Figure 37) occurred at δ 1.17 (\pm 0.03) ppm. Although the exact chemical shifts at which these signals occurred varied to within \pm 0.03 ppm, the major / minor relationship could be clearly observed.

¹H NMR analysis of the crude materials obtained after the reductive aminations indicated that the reductions had gone to completion. This was important because there were concerns that if the reductions had not gone to completion, then the observed diastereomeric ratios might have been due to a kinetic resolution operating in the reductive amination step, rather than the step leading to the Vilsmeier adduct. From the diastereomeric ratios that were obtained it was possible to infer, very approximately, what the enantiomeric ratio must have been of the α -formyl ketones. The results which were obtained were very encouraging. Evidently, the chiral chloroiminium salts had given rise to a degree of facial selectivity in the reaction of the pro-chiral enol (of the substrate) with the chloroiminium salt.

The results indicated that the reactions in which formamide **208** was used gave the highest diastereomeric ratios. The exact mechanistic explanation for this requires further studies. There may be greater conformational control in the chloroiminium salt derived from formamide **208** due to the '*gauche*' effect described previously.

Also, the presence of the fluoride substituent (rather than a methoxy group as in formamide **207**) may have ruled out the possibility of elimination occurring, thus enabling the chloroiminium salt to maintain its chiral integrity. Asymmetric synthesis is usually a process that is governed by kinetic control, and low temperatures usually give rise to higher asymmetric induction since lower temperatures allow for greater enantio-discrimination in the rate determining step. However in the data obtained for the asymmetric formylations (and subsequent reductive aminations) of α -methyl indanone and α -methyl tetralone, greater diastereomeric ratios were observed in those reactions which were conducted at higher temperatures. This can be explained with recourse to the equation which describes the free energies of the two diastereomeric transition states leading to the formation of the two enantiomers of the α -formyl ketone. For each diastereomeric transition state, the equation contains an enthalpy term and an entropy term:

$$\Delta G^\ddagger = \Delta H^\ddagger - T\Delta S^\ddagger \quad \text{equation 1}$$

For a high level of selectivity in an asymmetric reaction, a large difference is required in the free energies of the diastereomeric transition states:

$$\Delta\Delta G^\ddagger = \Delta G_1^\ddagger - \Delta G_2^\ddagger \quad \text{equation 2}$$

Where ΔG_1^\ddagger and ΔG_2^\ddagger are the free energies of the two diastereomeric transition states. Usually in asymmetric synthesis the enthalpy term is dominant and consequently greater selectivity is observed at lower temperature. However, if the entropy term is dominant then the difference between the free energies of the diastereomeric transition states increases as a function of temperature because of the temperature multiplier term which occurs before the entropy term in equation 1. It may be that in this particular reaction the entropy term is more important which may explain why greater diastereomeric ratios were observed in the reactions which were conducted at higher temperatures.

3.12 Attempt to determine absolute configuration of major diastereoisomer

Although the assaying method had enabled the approximate measurement of the diastereomeric ratios of the reductive amination products (and hence, the enantiomeric ratio of the α -formyl ketones), the absolute configurations of the major and minor diastereoisomers had not been determined. Ideally, in order to do this, it was necessary to obtain crystal structures, by x-ray diffraction, of the major diastereoisomers.

However isolation of the major diastereoisomers of **224**, and **225** was difficult. Even after column chromatography the materials isolated gave liquids whose ^1H NMR spectra indicated that they were of low purity, and therefore complete characterisation of these compounds was not achieved. However in the ^1H NMR spectra, the signals which corresponded to the major diastereoisomers were observable, and this is given in the experimental section. High resolution mass spectrometric analysis of the impure materials also confirmed the presence of the expected products (also given in the experimental section). Attempts were made to prepare solid derivatives of the major diastereoisomers that could be more easily purified and possibly recrystallized.

Unfortunately attempts to react a crude sample of compound **224** with naphthalene carboxylic acid were unsuccessful, and although a crude sample of compound **224** did react with benzoyl chloride, isolation of the pure product was not achieved. An attempt to react a crude sample of compound **225** with benzoyl chloride was also unsuccessful.

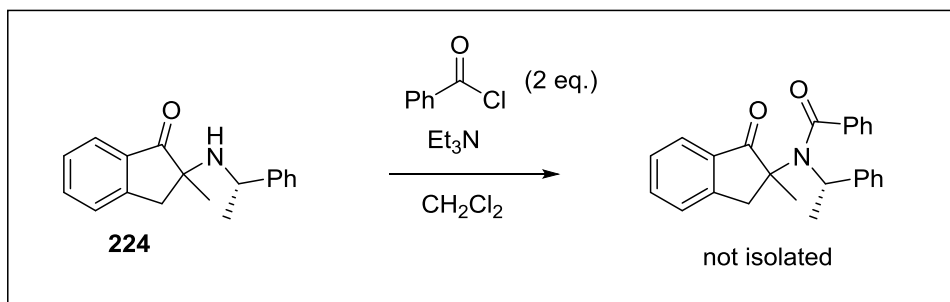

Scheme 122

Further work in this area will need to be directed towards elucidating the absolute structures of the major and minor diastereoisomers of **224**, and **225** or even of the corresponding α -formyl ketones **169** and **170** themselves. It is predicted that the major enantiomers of α -formyl ketones **169** and **170** will have the (*R*) configuration. This prediction is based on the postulate that the substrate is more likely to attack the chloroiminium salt at the less hindered face and with the enol oriented as depicted in the model shown in Scheme 123 (using α -methyl tetralone as an example). This orientation avoids non-bonding steric repulsion between the chloride substituent of the chloroiminium salt and the bicyclic part of the substrate.

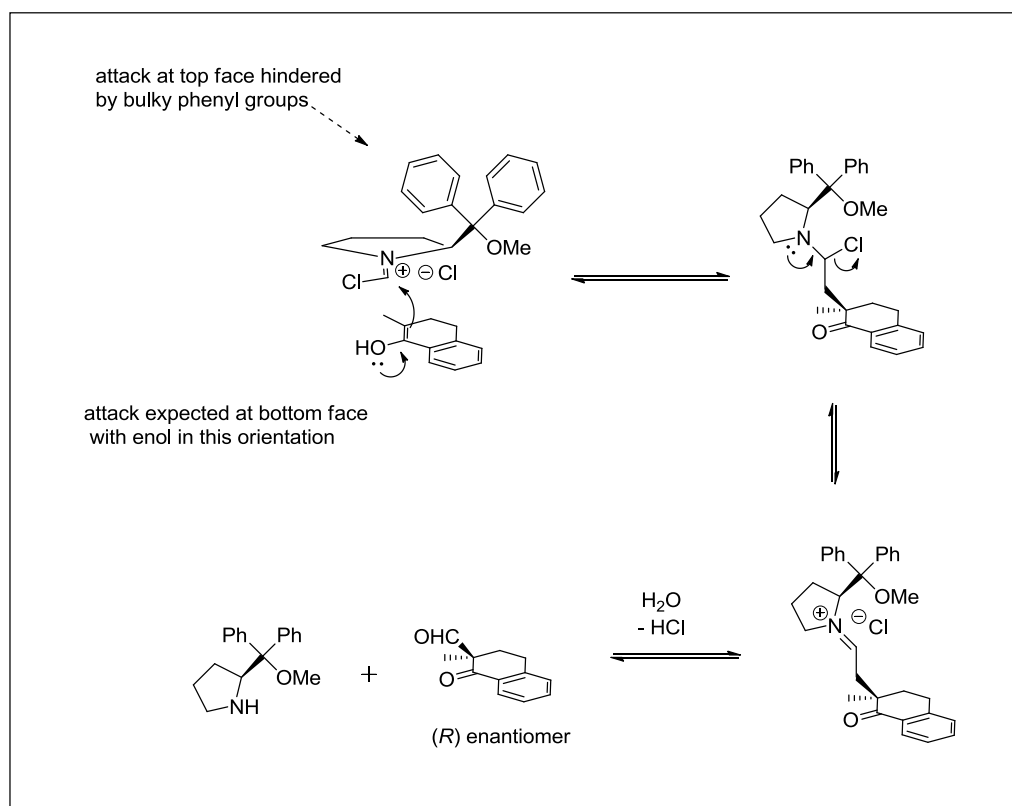

Scheme 123 Model to predict the absolute configuration of the major enantiomer in the α -formylation of α -methyl tetralone.

It is predicted that the enol is less likely to approach the chloroiminium salt in the orientation shown in Scheme 124 due to this non-bonding steric repulsion. Attack at this face leads to the formation of the (*S*) enantiomer.

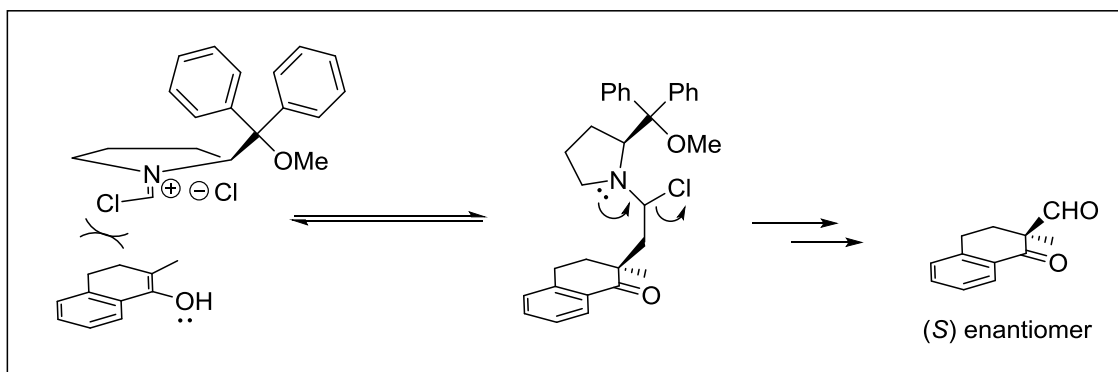

Scheme 124 Model to predict the absolute configuration of the minor enantiomer in the α -formylation of α -methyl tetralone.

3.13 Summary

In summary, a protocol has been found for the asymmetric α -formylation of α -methyl tetralone and α -methyl indanone, with the formation of quaternary stereogenic carbons, using chiral Vilsmeier reagents derived from (*S*)-proline. The reaction gives reasonable levels of asymmetric induction, and a reliable assaying method has been employed which circumvents the problem of decarbonylation of the α -formyl ketones during chromatography.

Chapter 4

Chapter 4 Experiments with other reaction types

4.1 Introduction

It had been demonstrated that the chiral formamides which had been prepared, could be used to achieve asymmetric formylations with an enantiomeric excess of up to 68%. Work was then directed towards extending the use of the chiral chloroiminium salts to other reactions. Early work had shown that silyl enol ethers react with DMF/ $(\text{COCl})_2$ to give an intermediate which, when hydrolysed with aqueous base, affords an α -formyl ketone. In fact, the first reaction of this kind was conducted using the chloroiminium salt derived from *N*-formyl-(*S*)-proline methyl ester **149** and oxalyl chloride. However the reproducibility of that reaction proved difficult. In subsequent work, formylation of silyl enol ethers gave crude mixtures which contained only small amounts of the desired α -formyl ketone product. Ketones were found to be much better substrates because they reacted to give α -formyl ketones with much higher levels of conversion and the crude products were cleaner.

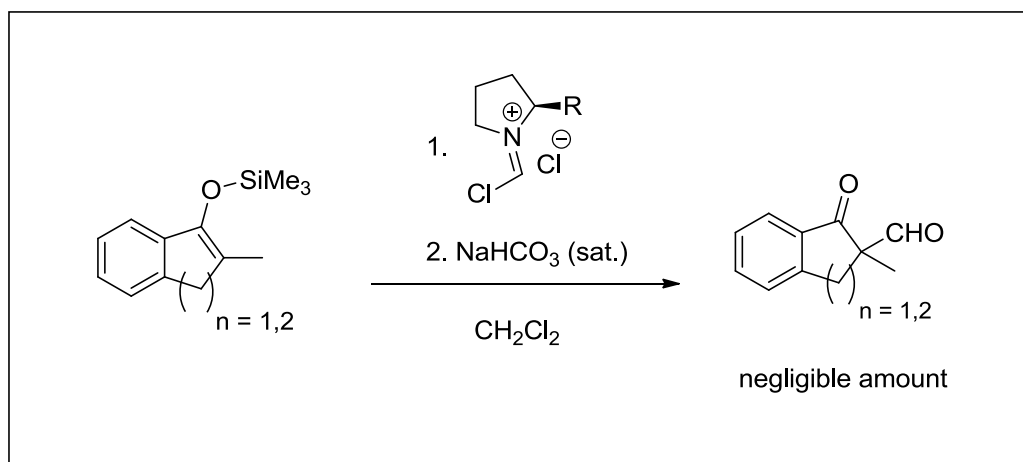

Scheme 125 α -Formylation of silyl enol ethers.

4.2 Preparation of 4-(2-methyl-3,4-dihydronaphthalen-1-yl)morpholine 226.

Work described in the last chapter had shown that α -methyl indanone and α -methyl tetralone can be formylated to give α -formyl ketones with fairly good levels of enantiomeric enrichment. It is known that enamines are more reactive nucleophiles than both enols and silyl enol ethers.¹²⁷ It was reasoned that an enamine of α -methyl tetralone might be a more reactive substrate than the ketone itself. If so, there was the potential of conducting an asymmetric formylation at much lower temperature and this might have allowed for greater enantio-discrimination in the rate determining step (assuming that the reaction was under kinetic control).

The morpholine derived enamine **226** was prepared as follows: 2-methyl-1-tetralone was dissolved in benzene, and to the solution was added morpholine (5 eq.), in a solution of benzene, and TiCl_4 as catalyst (0.7 eq.), and the reaction mixture heated at 50°C for 3 hours, and then at room temperature for 24 hours. The solvents were then removed *in vacuo* and the residue was purified by column chromatography (SiO_2) in dichloromethane to afford the product **226** as a yellow oil (59% isolated yield).

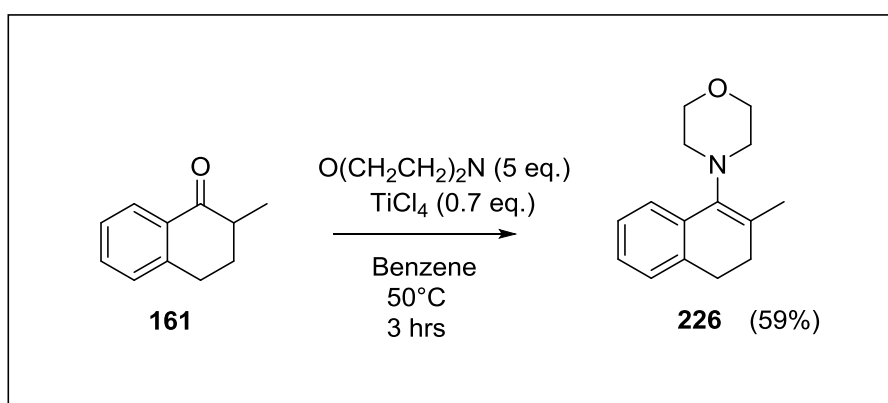

Scheme 126 Preparation of 4-(2-methyl-3,4-dihydronaphthalen-1-yl)morpholine.¹²⁸

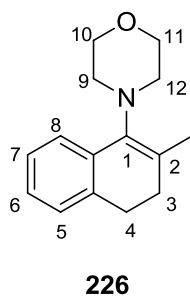
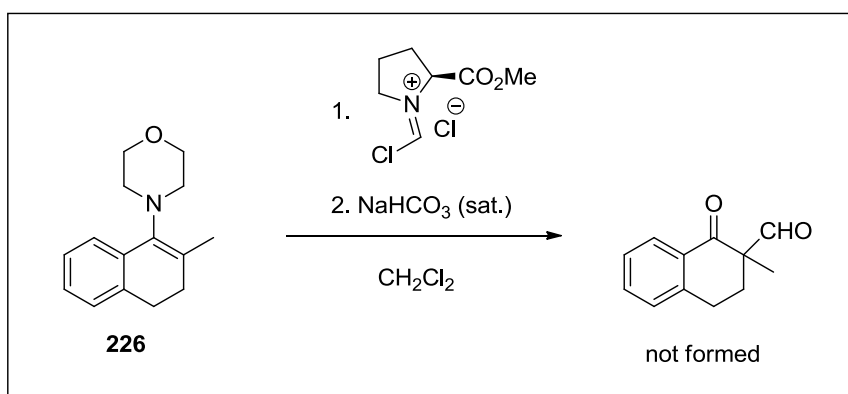

Figure 40

^1H NMR analysis of product **226** gave a 3H singlet at δ 1.48 ppm corresponding to the methyl protons, a 2H triplet at δ 2.17 ppm, $J = 8$ Hz, corresponding to the CH_2 protons at position 4, a 2H triplet at δ 2.64 ppm, $J = 8$ Hz, corresponding to the CH_2 protons at position 3, a 4H triplet at δ 3.01 ppm, $J = 4$ Hz, corresponding to the two sets of CH_2 protons at positions 9 and 12, and a 4H triplet at δ 3.72 ppm, $J = 4$ Hz, corresponding to the two sets of CH_2 protons at positions 10 and 11. The aromatic protons appeared in the region δ 7.01-7.45 ppm. This data was in agreement with that reported in the literature for this compound.¹²⁸

Then experiments were conducted aimed at the formylation of enamine **226**, using the chloroiminium salt derived from *N*-formyl-(*S*)-proline methyl ester **149** and oxalyl chloride as follows: *N*-formyl-(*S*)-proline methyl ester was dissolved in dry dichloromethane and the solution cooled to 0°C followed by the addition of 1 eq. of oxalyl chloride and the reaction mixture stirred for 1 hour under argon. Then the enamine **226** was added and the reaction mixture stirred at a set reaction time and temperature. After work up with aqueous base, the crude material was analysed by ^1H NMR spectroscopy, which indicated that no reaction had occurred. And this was the case even after the reaction conditions were changed (by heating at reflux for 24 hours).



Scheme 127 Attempted α -formylation of 4-(2-methyl-3,4-dihydronaphthalen-1-yl)morpholine.

It was known that the formation of a chloroiminium salt generates a small quantity of acid, and this may explain the unreactivity of the enamine in this reaction. If the nitrogen atom of the enamine is protonated by H^+ then it is not able to assist the carbon-carbon bonding forming step and the molecule is rendered non-nucleophilic.

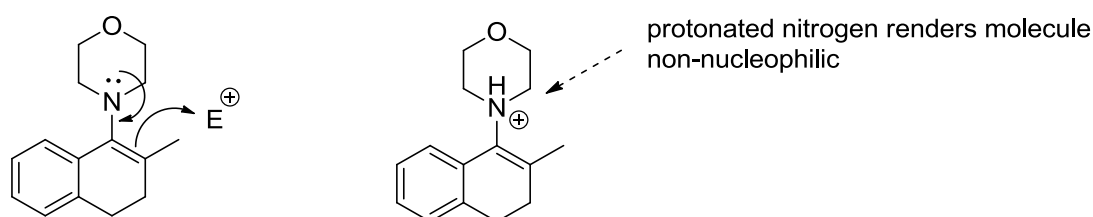

Figure 41

4.3 Attempted kinetic resolution of 1-phenylethanol

In a kinetic resolution one enantiomer of a racemic starting material reacts faster with a chiral reagent than the other enantiomer, and therefore an excess of the less reactive enantiomer gradually builds up as a function of time until it reaches a maximum, after which it diminishes and eventually disappears at the completion of the reaction.¹²⁹ If the reaction is stopped at any time before the completion of the reaction, or if less than one equivalent of the chiral reagent is used, then there will be a non-racemic mixture of the starting material in solution.¹²⁹ The process relies on the fact that the rates at which the two enantiomers react are significantly different *i.e.* $k_R \neq k_S$, where k_R = rate at which the (*R*) enantiomer reacts, and k_S = rate at which the (*S*) enantiomer reacts. The selectivity factor (*s*) is a parameter which describes the amount of enantio-discrimination in the reaction and it is defined as follows:¹²⁹

$$s = k_R / k_S = \exp (\Delta\Delta G^\ddagger / RT)$$

Where k_R is the rate of the fast reacting enantiomer and k_S is the rate of the slow reacting enantiomer and the term $\Delta\Delta G^\ddagger$ is the energy difference between the high and low energy transition states for the slow and fast reacting enantiomers respectively. For an ideal kinetic resolution $s \gg 100$.¹²⁹ A kinetic resolution of the secondary alcohol, 1-phenylethanol **227** was attempted. This alcohol reacts with oxalyl chloride, and a catalytic quantity of DMF, to give

(1-chloroethyl)benzene **228** (Scheme 128). The same reaction was conducted using chiral formamide **149** (to generate the chloroiminium salt) to see whether the reaction could be performed with any enantiomeric enrichment.

N-Formyl-(*S*)-proline methyl ester **149** (1 eq.) was dissolved in dry dichloromethane and the solution cooled to 0°C followed by a dropwise addition of oxalyl chloride (0.6 eq.), and the solution stirred under argon for 1 hour at 0°C, during which time the solution turned pale yellow. Then 1-phenylethanol **227** (1 eq.) was added and the reaction mixture stirred for 1 hour at 0°C. After work up with aqueous base, the unreacted 1-phenylethanol was isolated from the crude mixture by column chromatography (hexane/ethyl acetate 5:1) and analysed by chiral HPLC (5% isopropyl alcohol in hexane) to determine the ratio of two enantiomers. The trace indicated that the two enantiomers were present in a 1:1 ratio.

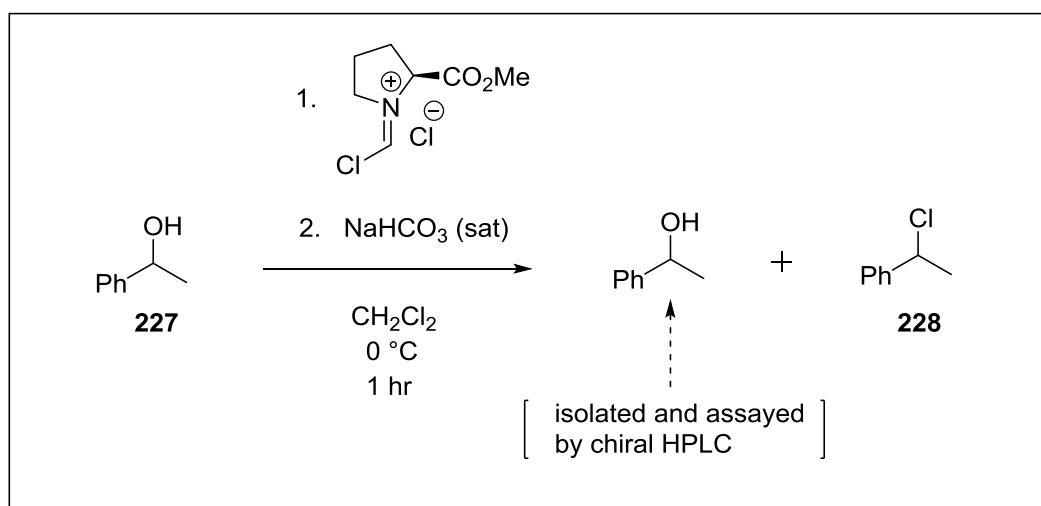

Scheme 128 Attempted kinetic resolution of 1-phenylethanol.

The result had indicated that no enantiomeric enrichment had occurred. The two enantiomers of the isolated 1-phenylethanol were present in a 50:50 ratio. Work was then directed towards attempting a kinetic resolution of a carboxylic acid, 2-phenylpropanoic acid **229** as described below.

4.4 Attempted kinetic resolution of 2-phenylpropanoic acid

Racemic 2-phenylpropanoic acid **229** reacts with oxalyl chloride, in the presence of a catalytic quantity of DMF, to give the acid chloride, 2-phenylpropanoyl chloride **230**. Experiments were conducted to see whether or not the same conversion to the acid chloride could be achieved using the chiral formamides **149** and **207**, as chiral catalysts, and if so, whether or not any enantiomeric enrichment was observed.

It was found that conversion to the acid chloride was achievable using 10 mol% of the formamides **149** and **207**. In order to assay for enantiomeric enrichment, the crude material containing the acid chloride was reacted with (*S*)- α -methylbenzylamine to give two diastereoisomers of the corresponding amide **231**. The relative amounts of the two diastereoisomers in the crude mixture were determined by ^1H NMR analysis. The most useful signal for this purpose was integration of the signals corresponding to methyl group adjacent to the carbonyl group (Figure 42).

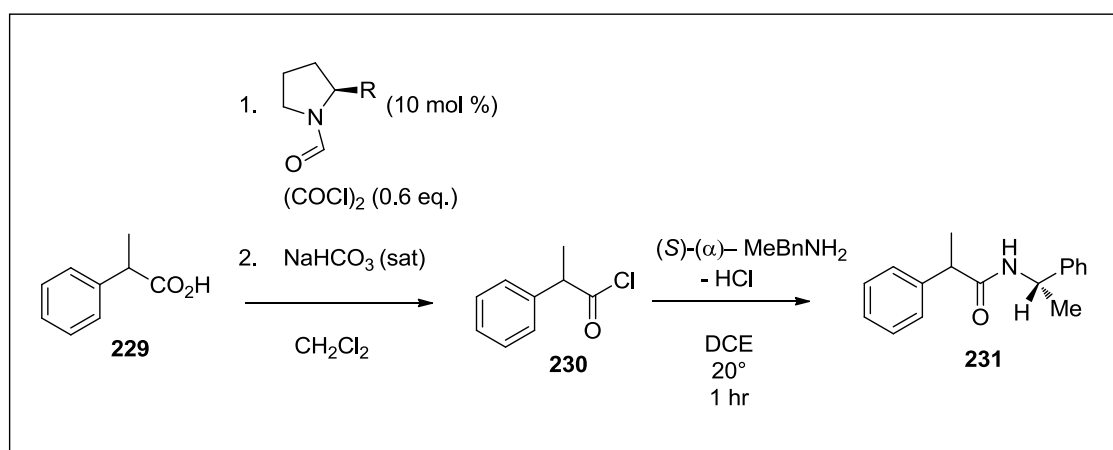

Scheme 129 Attempted kinetic resolution of 2-phenylpropanoic acid.

signal corresponding to methyl group
used in ^1H NMR assay

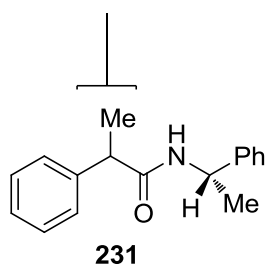

Figure 42

The following method was as employed: racemic 2-phenylpropanoic acid was dissolved in dichloromethane and to the solution was added the chiral formamide (10 mol % from a stock solution in dichloromethane) and then oxalyl chloride (0.6 eq.) was added dropwise to the solution, and the reaction mixture stirred for 1 hour at a certain temperature and reaction time. Then (*S*)-(-)- α -methylbenzylamine was added and the reaction mixture stirred for 1 hour. Work up with aqueous base (NaHCO₃) gave the crude material which was analysed by ¹H NMR spectroscopy to determine the ratio of two diastereoisomers. It was possible to identify which set of signals corresponded to which diastereoisomer by reference to ¹H NMR data contained in the literature for both diastereoisomers.¹³⁰

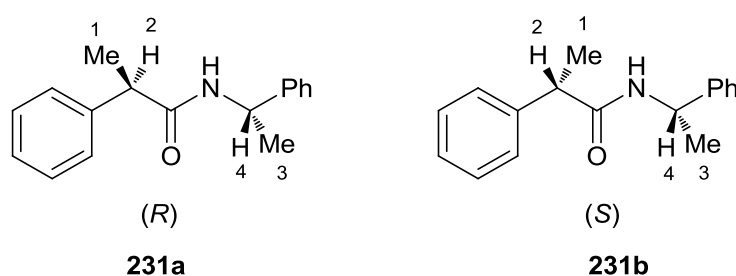

Figure 43

The experimental ¹H NMR data obtained was as follows: (*R*)-2-phenyl-*N*-[(*S*)-1-phenylethyl]propanamide **231a** gave the following ¹H NMR data: A 3H doublet at δ 1.36 ppm corresponding to the methyl protons at position 1, a 3H doublet at δ 1.52 ppm, $J = 7$ Hz, corresponding to the methyl protons at position 3, a 1H quartet at δ 3.56 ppm, $J = 7$ Hz, corresponding to the proton at position 2, a 1H quartet at δ 5.05 ppm, $J = 7$ Hz, corresponding to the proton at position 4 and a 1H singlet at δ 5.50 ppm corresponding to the NH proton. The aromatic protons appeared in the region δ 7.19-7.41 ppm.

(*S*)-2-phenyl-*N*-[(*S*)-1-phenylethyl]propanamide **231b** gave the following ¹H NMR data: A 3H doublet at δ 1.32 ppm corresponding to the methyl protons at position 1, a 3H doublet at δ 1.52 ppm, $J = 7$ Hz, corresponding to the methyl protons at position 3, a 1H quartet at δ 3.52 ppm, $J = 7$ Hz, corresponding to the proton at position 2, a 1H quartet at δ 5.01 ppm, $J = 7$ Hz, corresponding to the proton at position 4 and a 1H singlet at δ 5.62 ppm corresponding to the NH proton. The aromatic protons appeared in the region δ 7.17-7.41 ppm.

Table 24 shows the results obtained.

Table 24 Attempted kinetic resolution of 2-phenylpropanoic acid **229**.

formamide	solvent	temp. (°C)	% conversion	<i>d.r.</i>
149	dichloromethane	20	41	50 : 50
149	dichloromethane	0	35	50 : 50
149	dichloromethane	40	10	49 : 51
207	dichloromethane	20	42	51 : 49
207	dichloromethane	38	33	54 : 46
207	chloroform	61	30	51 : 49
207	toluene	115	48	50 : 50
207	dichloromethane	-78	38	50 : 50

4.5 Summary

The results indicated that there had been little kinetic resolution in the experiments. Even at low temperature no kinetic control was observed. One explanation for this is that the chirality of the chloroiminium salt is a relatively long distance away from the reactive site of the substrate, and therefore it is less likely that there will be any asymmetric induction.

4.6 Future work

Atroposelective formylation

Biaryl compounds containing bulky substituents at the *ortho* position exhibit a property known as atropisomerism, which arises due to restricted rotation around the bond linking the two aryl groups. Axially chiral biaryl compounds, such as BINAP, are important reagents in asymmetric catalysis, for example in the synthesis of enantiomerically pure naproxen.¹³¹ Work conducted in our laboratory has shown that biaryl compounds of the type **232**, which were prepared from commercially available naphthalene in four steps, can be formylated by Vilsmeier reagent to give the formylated analogues **233** and **234** (Scheme 130).

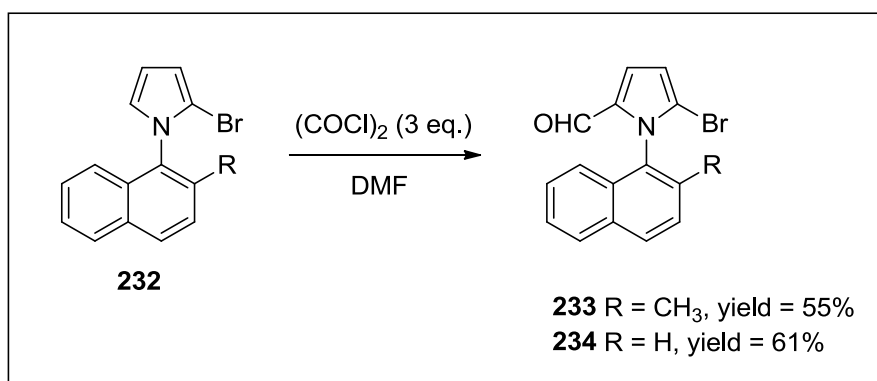

Scheme 130

If the same reaction is conducted using a chiral chloroiminium salt, then an asymmetric formylation may be possible, and this is an area where the asymmetric α -formylation work can be extended further.

Conclusion

The work conducted in this research has led to the discovery and development of a new method for the preparation of α -formyl- α -substituted ketones using a Vilsmeier reagent derived from the cheap and readily available reagents, DMF and oxalyl chloride. Cyclic aryl ketones were found to give the highest conversions. The α -formyl ketone products were found to be unstable with respect to decarbonylation during chromatography, but conditions were discovered whereby this tendency to decarbonylate is inhibited, namely, by employing an acidic mobile phase during chromatography. Moreover, a method was devised whereby the α -formyl ketones **169** and **170** were reductively aminated to give aminoketones which were far more stable. These modifications led to the isolation of nine new compounds. The various reaction parameters involved *i.e.* solvent, temperature, reaction time and the nature of the iminium salt itself, were investigated.

Work was then directed to the synthesis of three chiral formamides **149**, **207** and **208** with a view to extending the transformation to the asymmetric α -formylation of α -methyl indanone and α -methyl tetralone. Formamides **149** and **208** were prepared without difficulty, but initial attempts to prepare formamide **207** were unsuccessful due to the formation of an oxazolodinone side product in one of the steps of the synthesis. However this obstacle was overcome by changing the nature of the protecting group on the nitrogen of the pyrrolidine ring, and with this modification formamide **207** was successfully synthesised in six steps. Formamides **207** and **208** were new compounds.

The results obtained for the asymmetric α -formylation of α -methyl indanone and α -methyl tetralone were encouraging with enantiomeric excesses of up to 68%. A reliable method had been found for assaying the stereoselectivity in the reaction, namely by reacting the α -formyl ketone product with the chiral reagent (*S*)- α -methylbenzylamine thereby forming a pair of diastereoisomers whose relative amounts were determined by ^1H NMR analysis of the crude mixture. It remains to identify the absolute configurations of the major diastereoisomers. The extension of the asymmetric work to the kinetic resolutions of 1-phenylethanol and 2-propanoic acid was unsuccessful as no enantiomeric excess was observed in these experiments. However, a reliable method for assaying any stereoselectivity in those reactions was found. Future work can be directed towards developing work already conducted in our laboratory which has shown that biaryl compounds of the type **232** can be successfully formylated by Vilsmeier reagent.

Chapter 5: Experimental Section

General considerations.

All chemicals were reagent grade, and were purchased from chemical suppliers. All reactions were performed using dry solvents and under an argon atmosphere unless otherwise stated. Dichloromethane and chloroform were distilled over calcium hydride, and toluene and benzene were distilled over sodium. Tetrahydrofuran and diethyl ether were distilled over sodium and benzophenone, and dry 1,2-dichloroethane was obtained from Sigma Aldrich.

Thin layer chromatography was performed using Alugram Sil G/UV254 silica on aluminium sheets, and analysed with a UV lamp 254/365 nm and with I₂. Column chromatography was performed using silica gel 60 (230-400 mesh) and aluminium oxide (100-250 mesh).

NMR spectra were recorded on a Varian Unity Plus 400 MHz spectrometer and a Gemini (2000) 300 MHz spectrometer. IR spectra were recorded on a Perkin Elmer Spectrum 100 FT-IR spectrometer. Mass spectra were recorded at 'The EPSRC UK National Mass Spectrometry Facility', Swansea University.

Chiral HPLC experiments were performed on a Chiralcel OD column. Optical rotation experiments were performed using a Bellingham & Stanley ADP 220 polarimeter.

Experimental of Chapter 2

(±) 2-Methyl-1-indanone

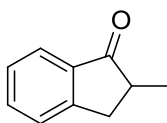

160

Lithium diisopropylamide was prepared *in situ* by adding *n*-butyllithium (29.7 mL, 41.6 mmol, 1.4 M in hexanes) to a solution of diisopropylamine (5.83 mL, 41.6 mmol) in tetrahydrofuran (20 mL), under an argon atmosphere, at 0°C in an ice bath. The solution was stirred at this temperature for 10 mins and then cooled to -78°C. Then a solution of 1-indanone (5.00 g, 37.8 mmol) in tetrahydrofuran (5 mL) was added to the LDA solution and the mixture stirred for 30 mins at -78°C, and then the temperature was allowed to rise to -20°C, with stirring. The temperature was then taken back down to -78°C and methyl iodide (2.36 mL, 37.8 mmol) was added dropwise to the solution, over 30 mins, and the mixture allowed to warm to room temperature, with stirring, over 2 hours. The reaction was then quenched by the addition of saturated aqueous ammonium chloride (10 mL), and the mixture extracted with diethyl ether (3 x 100 mL). The combined organic layers were dried over magnesium sulfate, filtered, and the solvents were removed *in vacuo*. Column chromatography (SiO₂) with hexane / ethyl acetate (20:1) gave the product as a red oil (0.80 g, 14%).

¹H NMR (400 MHz, CDCl₃): δ = 1.30 (d, 3H, *J* = 7 Hz, CH₃), 2.65-2.77 (m, 2H, CH₂), 3.40 (dd, 1H, *J* = 16, 8 Hz, CH), 7.37 (t, 1H, *J* = 8 Hz, ArH), 7.45 (d, 1H, *J* = 8 Hz), 7.59 (t, 1H, *J* = 8 Hz, ArH), 7.76 (d, 1H, *J* = 8 Hz, ArH). This data was in agreement with that reported in the literature for this compound.¹³²

(±) 2-Benzyl-1-indanone

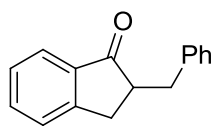

174

Lithium diisopropylamide was prepared *in situ* by adding *n*-butyllithium (11.9 mL, 16.6 mmol, 1.4 M in hexanes) to a solution of diisopropylamine (2.33 mL, 16.6 mmol) in tetrahydrofuran (10 mL), under an argon atmosphere, at 0°C on an ice bath. The solution was stirred at this temperature for 10 mins and then cooled to -78°C. Then a solution of 1-indanone (2.00 g, 15.1 mmol) in tetrahydrofuran (5 mL) was added to the LDA solution and the mixture stirred for 30 mins at -78°C, and then the temperature was allowed to rise to 0°C, with stirring. The temperature was then taken back down to -78°C and benzyl bromide (1.80 mL, 15.1 mmol) was added dropwise to the solution, over 30 mins, and the mixture allowed to warm to room temperature, with stirring, over 2 hours. The reaction was then quenched by the addition of saturated aqueous ammonium chloride (10 mL), and the mixture extracted with diethyl ether (3 x 50 mL). The combined organic layers were dried over magnesium sulfate, filtered, and the solvents were removed *in vacuo*. Column chromatography (SiO₂) with hexane / ethyl acetate (20:1) gave the product as a yellow oil (1.15 g, 34%).¹⁰³

¹H NMR (400 MHz, CDCl₃): δ = 2.63 (dd, 1H, *J* = 13, 11 Hz, PhCHH), 2.84 (dd, 1H, *J* = 16, 4 Hz, CHH), 2.91-3.02 (m, 1H, CH), 3.15 (dd, 1H, *J* = 16, 8 Hz, CHH), 3.38 (dd, 1H, *J* = 13, 4 Hz, PhCHH), 7.17-7.39 (m, 7H, ArH), 7.55 (t, 1H, *J* = 8 Hz, ArH), 7.75 (d, 1H, *J* = 8 Hz, ArH). This data was in agreement with that reported in the literature for this compound.¹⁰³

(±) 2-Methyl-1-tetralone

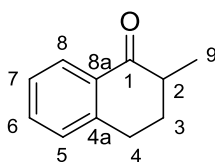

161

Lithium diisopropylamide was prepared *in situ* by adding *n*-butyllithium (32.2 mL, 45.1 mmol, 1.4 M in hexanes) to a solution of diisopropylamine (6.33 mL, 45.1 mmol) in tetrahydrofuran

(20 mL), under an argon atmosphere, at 0°C on an ice bath. The solution was stirred at this temperature for 10 mins and then cooled to -78°C. Then a solution of α -tetralone (6.0 g, 41.0 mmol) in tetrahydrofuran (5 mL) was added to the LDA solution and the mixture stirred for 30 mins at -78°C. Then methyl iodide (2.56 mL, 41.0 mmol) was added dropwise to this solution, over 30 mins, and the mixture allowed to warm to room temperature, with stirring, over 2 hours. The reaction was then quenched by the addition of saturated aqueous ammonium chloride (10 mL), and the mixture extracted with diethyl ether (3 x 100 mL). The combined organic layers were dried over magnesium sulfate, filtered, and the solvents were removed *in vacuo*. Column chromatography (SiO₂) with hexane / ethyl acetate (30:1) gave the product as a purple oil (2.59 g, 39%).

¹H NMR (400 MHz, CDCl₃): δ = 1.13 (d, 3H, J = 8 Hz, CH₃), 1.69 (ddd, 1H, J = 14, 8, 5 Hz, CHH), 1.99-2.06 (m, 1H, CHH), 2.35-2.45 (m, 1H, CH), 2.75-2.91 (m, 2H, CH₂), 7.06 (d, 1H, J = 8 Hz, ArH), 7.13 (t, 1H, J = 8 Hz, ArH), 7.29 (t, 1H, J = 8 Hz, ArH), 7.90 (d, 1H, J = 8 Hz, ArH). ¹³C NMR (400 MHz, CDCl₃): δ = 15.6 (C9), 29.0 (C4), 31.5 (C3), 42.7 (C2), 126.6 (C7), 127.4 (C8), 128.9 (C5), 132.5 (C8a), 133.2 (C6), 144.3 (C4a), 200.6 (C=O). This data was in agreement with that reported in the literature for this compound.¹⁰⁴

(\pm) 2-Allyl-1-tetralone

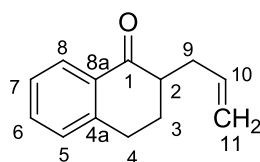

176

Lithium diisopropylamide was prepared *in situ* by adding *n*-butyllithium (26.9 mL, 37.6 mmol, 1.4 M in hexanes) to a solution of diisopropylamine (5.27 mL, 37.6 mmol) in tetrahydrofuran (10 mL), under an argon atmosphere, at 0°C on an ice bath. The solution was stirred at this temperature for 10 mins and then cooled to -78°C. Then a solution of α -tetralone (5.0 g, 34.2 mmol) in tetrahydrofuran (10 mL) was added to the LDA solution and the mixture stirred for 30 mins at -78°C. Then allyl bromide (2.96 mL, 34.2 mmol) was added dropwise to the solution, and the mixture allowed to warm to room temperature, with stirring, over 2 hours. The reaction was then quenched by the addition of saturated aqueous ammonium chloride (10 mL), and the mixture extracted with diethyl ether (3 x 100 mL). The combined organic layers

were dried over magnesium sulfate, filtered, and the solvents were removed *in vacuo*. Column chromatography (SiO₂) with hexane / ethyl acetate (10:1) gave the product as a colourless oil (1.63 g, 26%).

¹H NMR (400 MHz, CDCl₃): δ = 1.65-1.75 (m, 1H, CH₂-CHH-CH), 2.13-2.26 (m, 2H, CH₂-CHH-CH, CH), 2.42-2.53 (m, 1H, CHH-CH=CH₂), 2.66-2.75 (m, 1H, CHH-CH=CH₂), 2.81-2.84 (m, 2H, CH₂-CH₂-CH), 5.02 (d, *J* = 10 Hz, =CHH) 5.06 (d, *J* = 16 Hz =CHH), 5.63-5.77 (m, 1H, CH=CH₂), 7.14 (d, 1H, *J* = 8 Hz, ArH), 7.16 (t, 1H, *J* = 8 Hz, ArH), 7.30 (t, 1H, *J* = 8 Hz, ArH), 7.89 (d, 1H, *J* = 8 Hz, ArH). ¹³C NMR (400 MHz, CDCl₃): δ = 28.2 (C3), 28.8 (C4) 34.3 (C9), 47.3 (C2), 117.0 (C11), 126.8 (C7), 127.6 (C5), 129.0 (C8), 133.4 (C6), 133.7 (C8a), 136.4 (C10), 144.3 (C4a), 199.5 (C=O). This data was in agreement with that reported in the literature for this compound.¹⁰⁴

(±) 2-Phenyl-1-Tetralone

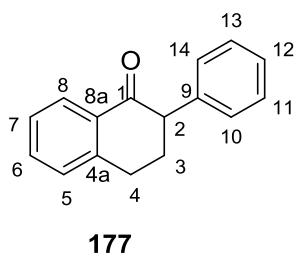

A schlenk flask was evacuated, dried with a heating gun, and back filled with argon. Then sodium *tert*-butoxide (4.27 g, 44.4 mmol) and palladio-phosphorus compound **178** (212 mg, 0.34 mmol) were placed in the flask and the flask re-evacuated and then back filled with argon. Then toluene (30 mL), bromobenzene (3.00 mL, 28.5 mmol) and α-tetralone (5.00 g, 34.2 mmol) were sequentially added to the flask and the mixture heated at reflux for 24 hours. The solvent was then removed *in vacuo* and the residue dissolved in diethyl ether (50 mL) and washed with water (10 mL). The aqueous layer was then extracted with more diethyl ether (2 x 50 mL), and the combined organic layers dried over magnesium sulfate, filtered, and the solvent removed *in vacuo*. Column chromatography (SiO₂) with hexane / ethyl acetate (20:1) gave the product as a pale orange oil (0.34 g, 4%).

^1H NMR (400 MHz, CDCl_3): δ = 2.37-2.48 (m, 2H, $\text{CH}_2\text{-CH}_2\text{-CH}$), 2.99-3.15 (m, 2H, $\text{CH}_2\text{-CH}_2\text{-CH}$), 3.79 (dd, 1H, J = 8, 4 Hz), 7.16-7.37 (m, 7H, ArH), 7.49 (t, 1H, J = 8 Hz, ArH), 8.10 (d, 1H, J = 8 Hz, ArH). ^{13}C NMR (400 MHz, CDCl_3): δ = 29.0 (C3), 31.4 (C4), 54.6 (C2), 127.0 (C12), 127.2 (C7), 128.0 (C11, C13), 128.7 (C5), 128.8 (C8), 129.0 (C10, C14), 133.1 (C6), 133.7 (C8a), 140.0 (C9), 144.3 (C4a), 198.5 (C=O). This data was in agreement with that reported in the literature for this compound.¹⁰⁶

Trimethyl[(2-methyl-1*H*-inden-3-yl)oxy]silane

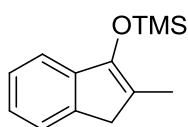

167

Lithium diisopropylamide was prepared *in situ* by adding *n*-butyllithium (9.77 mL, 13.7 mmol, 1.4 M in hexanes) to a solution of diisopropylamine (1.93 mL, 13.7 mmol) in tetrahydrofuran (10 mL), under an argon atmosphere, at 0°C on an ice bath. The solution was stirred at this temperature for 10 mins and then cooled to -78°C. Then a solution of 2-methyl-1-indanone (2.00 g, 13.7 mmol) in tetrahydrofuran (5 mL) was added to the LDA solution and the mixture stirred for 30 mins at -78°C. Then trimethylsilylchloride (5.20 mL, 41.0 mmol) was added to this solution, and the mixture allowed to warm to room temperature, with stirring, over 2 hours. The reaction mixture was then diluted by the addition of diethyl ether (30 mL) and filtered to remove solid by-products. The filtrate was collected, and the solvent removed *in vacuo*. The residue was distilled at low pressure, using a Kugelrohr apparatus, to afford the product as a yellow oil (1.20 g, 40 %).

^1H NMR (400 MHz, CDCl_3): δ = 0.24 (s, 9H, $\text{Si}(\text{CH}_3)_3$), 1.97 (s, 3H, CH_3), 3.19 (s, 2H, CH_2), 7.08-7.33 (m, 4H, ArH). This data was in agreement with that reported in the literature for this compound.¹³³

Trimethyl[(2-methyl-3,4-dihydronaphthalen-1-yl)oxy]silane

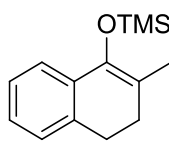

168

Lithium diisopropylamide was prepared *in situ* by adding *n*-butyllithium (4.17 mL, 10.4 mmol, 2.5 M in hexanes) to a solution of diisopropylamine (1.46 mL, 10.4 mmol) in tetrahydrofuran (5 mL), under an argon atmosphere, at 0°C in an ice bath. The solution was stirred at this temperature for 10 mins and then cooled to -78°C. A solution of 2-methyl-1-tetralone (1.67 g, 10.4 mmol) in tetrahydrofuran (5 mL) was added to the LDA solution and the mixture stirred for 30 mins at -78°C. Then trimethylsilyl chloride (3.96 mL, 31.2 mmol) was added to this solution, and the mixture allowed to warm to room temperature, with stirring, over 2 hours. The reaction mixture was then diluted by the addition of diethyl ether (30 mL) and filtered to remove solid by-products. The filtrate was collected, and the solvent removed *in vacuo*. Column chromatography (SiO₂) with hexane / ethyl acetate (10:1) gave the product as a pale yellow oil. (1.29 g, 53 %).

¹H NMR (400 MHz, CDCl₃): δ = 0.09 (s, 9H, Si(CH₃)₃), 1.34 (s, 3H, CH₃), 2.05 (t, 2H, *J* = 8 Hz, CH₂-CH₂-CMe), 2.53 (t, 2H, *J* = 8 Hz, CH₂-CH₂-CMe), 6.87-7.19 (m, 4H, ArH). This data was in agreement with that reported in the literature for this compound.¹³³

Cyclohexen-1-yloxy(trimethyl)silane

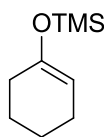

152

Cyclohexanone (10.0g, 101.9 mmol) was dissolved in *N,N*-dimethylformamide (50 mL) and to the solution was added triethylamine (42.6 mL, 305.7 mmol) and trimethylsilylchloride (16.8 mL, 132.4 mmol) under an argon atmosphere, and the solution heated at reflux for 24 hours. The reaction mixture was then diluted by the addition of (30-40) petroleum ether (100 mL) and washed with saturated sodium hydrogen carbonate (2 x 150 mL) and 0.1M hydrochloric acid (40 mL). The organic layer was collected, dried over magnesium sulphate, filtered, and the

solvents removed *in vacuo*. The residue was distilled at low pressure, using a Kugelrohr apparatus, to give the product as a colourless oil (1.04 g, 6 %).

^1H NMR (400 MHz, CDCl_3): $\delta = -0.98$ (s, 9H, $\text{Si}(\text{CH}_3)_3$), 1.32-1.54 (m, 4H, $(\text{CH}_2)_2$), 1.77-1.85 (m, 4H, $(\text{CH}_2)_2$), 4.65-4.73 (m, 1H, CH). This data was in agreement with that reported in the literature for this compound.¹³⁴

(±) 2-Methyl-1-oxoindane-2-carbaldehyde

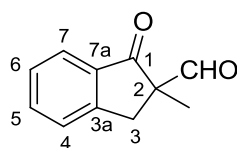

169

To a solution of *N,N*-dimethylformamide (1.29 mL, 16.6 mmol) in dry dichloromethane (50 mL) was added dropwise, oxalyl chloride (1.43 mL, 16.6 mmol), at 0°C and the solution was stirred under argon for 1 hour, at this temperature, during which time the solution turned pale yellow. Then 2-methyl-1-indanone (0.810 g, 5.54 mmol) was added, and the reaction mixture was stirred at room temperature for 24 hours. The reaction was quenched by the addition of saturated sodium hydrogen carbonate (20 mL) with stirring. The dichloromethane was removed *in vacuo*, and the remaining aqueous phase was extracted with a mixture of pentane (200 mL) and diethyl ether (30 mL). Following removal of the aqueous layer, the organic layer was washed with saturated aqueous sodium hydrogen carbonate (2 × 100 mL). The combined organic layers were then collected, dried over magnesium sulfate, filtered, and the solvent was removed *in vacuo* to afford the desired material as a pale yellow oil (0.850 g, 88%).

^1H NMR (300 MHz, CDCl_3): $\delta = 1.55$ (3 H, s CH_3), 2.85 (1H, d, $J = 17$ Hz, CHH), 3.83 (1H, d, $J = 17$ Hz, CHH), 7.37 (1 H, t, $J = 8$ Hz, ArH), 7.45 (1H, d, $J = 8$ Hz, ArH), 7.59 (1H, t, $J = 8$ Hz, ArH), 7.76 (1H, d, $J = 8$ Hz, ArH), 9.59 (1H, s, CHO). ^{13}C NMR (400 MHz, CDCl_3): $\delta = 18.9$ (CH_3), 30.3 (C3), 62.7 (C2), 124.3 (C4), 126.5 (C7), 127.5 (C7a), 134.3 (C5), 135.3 (C3a), 152.4 (C6), 196.5, (CHO) 202.4 (C1). IR (neat): $\nu_{\text{max}} = 1736, 1704, 1608, 1465, 1278$ cm^{-1} . HMRS (ES): m/z calcd for $\text{C}_{11}\text{H}_{11}\text{O}_2$ [MH^+]: 175.0754; found: 175.0752.

(±) 2-Benzyl-1-oxoindane-2-carbaldehyde

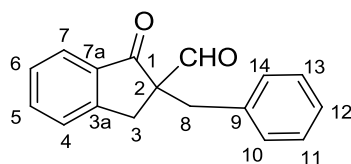

179

To a solution of *N,N*-dimethylformamide (0.87 mL, 11.2 mmol) in dry dichloromethane (20 mL) was added dropwise, oxalyl chloride (0.95 mL, 11.2 mmol), at 0°C and the solution was stirred under argon for 1 hour, at this temperature, during which time the solution turned pale yellow. Then 2-benzyl-1-indanone (0.830 g, 3.73 mmol) was added, and the reaction mixture was stirred at room temperature for 24 hours. The reaction was then diluted with dichloromethane (10 mL) and quenched by the addition of saturated aqueous sodium hydrogen carbonate (10 mL). Following separation, the aqueous layer was extracted with dichloromethane (3 × 50 mL). The combined organic layers were dried over magnesium sulfate, filtered, and the solvent was removed *in vacuo*. Column chromatography (SiO₂) with 2% formic acid–10% EtOAc / hexane gave the product a yellow oil (346 mg, 37%).

¹H NMR (400 MHz, CDCl₃): δ = 2.98 (d, 1H, *J* = 18 Hz, *CHH*), 3.32 (d, 1H, *J* = 14 Hz, *PhCHH*), 3.42 (d, 1H, *J* = 14 Hz, *PhCHH*), 3.62 (d, 1H, *J* = 18 Hz, *CHH*), 7.08-7.22 (m, 5H, *ArH*), 7.32 (t, 1H, *J* = 8 Hz, *ArH*), 7.39 (d, 1H, *J* = 8 Hz, *ArH*), 7.55 (t, 1H, *J* = 8 Hz, *ArH*), 7.69 (d, 1H, *J* = 8 Hz, *ArH*), 9.70 (s, 1H, *CHO*). ¹³C NMR (400 MHz, CDCl₃): δ = 31.1 (C8), 38.8 (C3), 69.1 (C2), 124.7 (C6), 126.8 (C4), 127.3 (C11, C13), 128.1 (C7), 128.4 (C9, C12), 128.9 (C10, C14), 135.3 (C7a), 135.9 (C5), 153.6 (C3a), 198.0 (*CHO*), 201.9 (C1). IR (neat): ν_{max} = 3058, 1735, 1701, 1633, 1276, 766, 707 cm⁻¹. HRMS (ES): *m/z* calcd for C₁₂H₁₃O₂ [*M*+NH₄⁺]: 268.1332; found: 268.1336.

(±) 2-Methyl-1-oxo-1,2,3,4-tetrahydronaphthalene-2-carbaldehyde

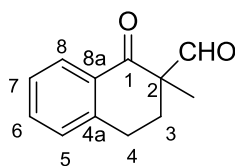

170

To a solution of *N,N*-dimethylformamide (0.72 mL, 9.4 mmol) in dry dichloromethane (35 mL) was added dropwise, oxalyl chloride (0.79 mL, 9.4 mmol), at 0°C and the solution was stirred under argon for 1 hour, at this temperature, during which time the solution turned pale yellow. Then 2-methyl-1-tetralone (0.500 g, 3.12 mmol) was added, and the reaction mixture was heated at reflux for 24 hours. The reaction was then diluted with dichloromethane (20 mL) and quenched by the addition of saturated aqueous sodium hydrogen carbonate (20 mL). Following separation, the aqueous layer was extracted with dichloromethane (3 × 50 mL). The combined organic layers were dried over magnesium sulfate, filtered, and the solvent was removed *in vacuo*. Column chromatography (SiO₂) with 2% formic acid–5% EtOAc–hexane gave the product as a colourless oil (202 mg, 34%).

¹H NMR (300 MHz, CDCl₃): δ = 1.39 (3H, s, CH₃), 1.98 (1H, ddd, *J* = 14, 8, 5 Hz, CHH), 2.48 (1H, ddd, *J* = 14, 8, 5 Hz, CHH), 2.96–3.06 (2 H, m, CH₂), 7.23 (1H, d, *J* = 8 Hz, ArH), 7.31 (1H, t, *J* = 8 Hz, ArH), 7.49 (1H, t, *J* = 8 Hz, ArH), 8.02 (1H, d, *J* = 8 Hz, ArH), 9.73 (1H, s, CHO). ¹³C NMR (400 MHz, CDCl₃): δ = 18.3 (CH₃), 25.1 (C4), 29.3 (C3), 57.9 (C2), 127.0 (C7), 127.8 (C5), 128.9 (C8), 131.4 (C8a), 134.1 (C6), 143.5 (C4a), 197.5 (C1), 201.0 (CHO). IR (neat): ν max = 1724, 1671, 1600, 1455, 1304, 1225 cm⁻¹. HRMS (ES): *m/z* calcd for C₁₂H₁₃O₂ [MH⁺]: 189.0910; found: 189.0909. This data was in agreement with that reported in the literature for this compound.¹⁰¹

(±) 2-Allyl-1-oxo-1,2,3,4-tetrahydronaphthalene-2-carbaldehyde

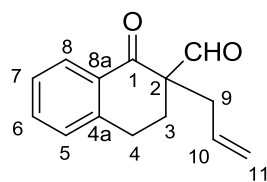

To a solution of *N,N*-dimethylformamide (1.62 mL, 20.9 mmol) in dry dichloromethane (35 mL) was added dropwise, oxalyl chloride (1.77 mL, 20.9 mmol), at 0°C and the solution was stirred under argon for 1 hour, at this temperature, during which time the solution turned pale yellow. Then 2-allyl-1-tetralone (1.20 g, 6.44 mmol) was added, and the reaction mixture was heated at reflux for 24 hours. The reaction was then diluted with dichloromethane (20 mL) and quenched by the addition of saturated aqueous sodium hydrogen carbonate (20 mL). Following separation, the aqueous layer was extracted with dichloromethane (3 × 50 mL). The combined organic layers were dried over magnesium sulfate, filtered, and the solvent was removed *in vacuo*. Column chromatography (SiO₂) with 2% formic acid–5% EtOAc / hexane gave the product as a colourless oil (620 mg, 45%).

¹H NMR (400 MHz, CDCl₃): δ = 2.06 (ddd, 1H, *J* = 14, 8, 5 Ar-CH₂-CHH), 2.39 (ddd, 1H, *J* = 14, 7, 5 Ar-CH₂-CHH), 2.59-2.70 (m, 2H, CH₂-CH=CH₂), 2.87-3.03 (m, 2H, Ar-CH₂), 5.07-5.09 (m, 1H, CH=CHH) 5.10-5.13 (m, 1H, CH=CHH) 5.56-5.67 (m, 1H, CH=CH₂), 7.18 (d, 1H, *J* = 8 Hz, ArH), 7.29 (t, 1H, *J* = 8 Hz, ArH), 7.45 (t, 1H, *J* = 8 Hz, ArH), 7.98 (d, 1H, *J* = 8 Hz, ArH), 9.70 (s, 1H, CHO). ¹³C NMR (400 MHz, CDCl₃): δ = 25.3 (C4), 26.3 (C3), 61.8 (C9), 120.0 (C2), 127.2 (C11), 128.0 (C7), 129.0 (C5), 131.8 (C8a, C8), 132.0 (C6), 134.3 (C10), 143.8 (C4a), 196.4 (C1), 200.9 (CHO). IR (neat): ν max = 1731, 1672, 1601, 1227, 925, 743 cm⁻¹. HRMS (ES): *m/z* calcd for C₁₄H₁₄O₂ [MH⁺]: 215.1067; found: 215.1070.

2-Phenyl-3,4-dihydronaphthalen-1-yl formate

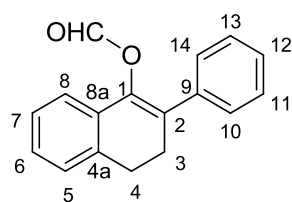

To a solution of *N,N*-dimethylformamide (0.36 mL, 4.59 mmol) in dry dichloromethane (20 mL) was added dropwise, oxalyl chloride (0.39 mL, 4.59 mmol), at 0°C and the solution was stirred under argon for 1 hour, at this temperature, during which time the solution turned pale yellow. Then 2-phenyl-1-tetralone (0.340 g, 1.53 mmol) was added, and the reaction mixture was heated at reflux for 24 hours. The reaction was then diluted with dichloromethane (20 mL) and quenched by the addition of saturated aqueous sodium hydrogen carbonate (10 mL). Following separation, the aqueous layer was extracted with dichloromethane (3 × 50 mL). The combined organic layers were dried over magnesium sulfate, filtered, and the solvent was removed *in vacuo*. Column chromatography (SiO₂) with 2% formic acid–5% EtOAc / hexane gave the product as a colourless oil (0.322 mg, 84%).

¹H NMR (400 MHz, CDCl₃): δ = 2.73 (t, 2H, *J* = 8 Hz, CH₂), 2.90 (t, 2H, *J* = 8 Hz, CH₂), 7.07–7.32 (m, 9H, ArH), 7.92 (s, 1H, CHO). ¹³C NMR (400 MHz, CDCl₃): δ = 28.0 (C3), 29.2 (C4), 121.8 (C5), 127.0 (C8), 127.7 (C7), 127.9 (C2, C6), 128.2 (C10, C14), 128.5 (C12), 128.8 (C11, C13), 130.8 (C9), 136.1 (C8a), 138.0 (C1), 140.1 (C4a), 159.9 (CHO). IR (neat): ν max = 2942, 1739, 1490, 1266, 1136, 1112, 909 cm⁻¹. HRMS (ES): *m/z* calcd for C₁₇H₁₄O₂ [M+NH₄⁺]: 269.1366; found: 269.1359.

2,2-Dimethyl-3-oxo-3-phenylpropanal

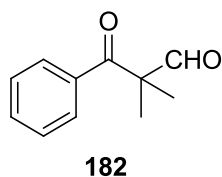

To a solution of *N,N*-dimethylformamide (0.78 mL, 10.1 mmol) in dry dichloromethane (20 mL) was added dropwise, oxalyl chloride (0.86 mL, 10.1 mmol), at 0°C and the solution was stirred under argon for 1 hour, at this temperature, during which time the solution turned pale yellow. Then isobutyrophenone (0.500 g, 3.37 mmol) was added, and the reaction mixture was heated at reflux for 24 hours. The reaction was then diluted with dichloromethane (20 mL) and quenched by the addition of saturated aqueous sodium hydrogen carbonate (10 mL). Following separation, the aqueous layer was extracted with dichloromethane (3 × 50 mL). The combined organic layers were dried over magnesium sulfate, filtered, and the solvent was removed *in vacuo*. Column chromatography (SiO₂) with hexane / ethyl acetate gave the product as a colourless oil (0.050 mg, 8%).

¹H NMR (400 MHz, CDCl₃): δ = 1.46 (s, 6H, (CH₃)₂), 7.41 (t, 2H, *J* = 8 Hz, ArH), 7.52 (t, 1H, *J* = 8 Hz, ArH), 7.75 (d, 2H, *J* = 8 Hz, ArH), 9.75 (s, 1H, CHO). This data was in agreement with that reported in the literature for this compound.¹⁰⁷

2,2,4-Trimethyl-3-oxopentanal

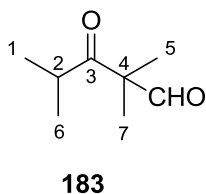

To a solution of *N,N*-dimethylformamide (1.01 mL, 13.1 mmol) in dry dichloromethane (30 mL) was added, dropwise, oxalyl chloride (1.11 mL, 13.1 mmol), at 0°C and the solution was stirred under argon for 1 hour, at this temperature, during which time the solution turned pale yellow. Then 2,4-dimethyl-3-pentanone (0.500 g, 4.35 mmol) was added, and the reaction mixture was heated at reflux for 24 hours. The reaction was then diluted with dichloromethane (20 mL) and quenched by the addition of saturated aqueous sodium hydrogen carbonate (20 mL). Following separation, the aqueous layer was extracted with dichloromethane (3 × 50 mL).

The combined organic layers were dried over magnesium sulfate, filtered, and the solvent was removed *in vacuo*. Column chromatography (SiO₂) with hexane / ethyl acetate (10:1) gave the product as a colourless oil (0.250 mg, 40%).

¹H NMR (400 MHz, CDCl₃): δ = 1.00 (d, 6H, *J* = 7 Hz, (CH₃)₂), 1.28, (s, 6H, (CH₃)₂), 2.86 (sept, 1H, *J* = 7 Hz, CH), 9.59 (s, 1H, CHO). ¹³C NMR (400 MHz, CDCl₃): δ = 19.2 (C1, C6), 19.5 (C5, C7), 36.8 (C2), 69.1 (C4), 201.4 (CHO), 214.1 (C3). This data was in agreement with that reported in the literature for this compound.¹⁰⁸

(±) 2-Hydroxy-3-methylcyclohex-1-ene-1,3-dicarbaldehyde

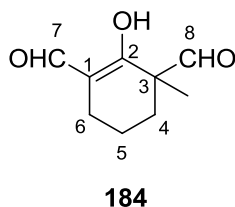

To a solution of *N,N*-dimethylformamide (1.60 mL, 20.7 mmol) in dry dichloromethane (30 mL) was added, dropwise, oxalyl chloride (1.75 mL, 20.7 mmol), at 0°C and the solution was stirred under argon for 1 hour, at this temperature, during which time the solution turned pale yellow. Then 2-methylcyclohexanone (0.774 g, 6.90 mmol) was added, and the reaction mixture was heated at reflux for 24 hours. The reaction was then diluted with dichloromethane (20 mL) and quenched by the addition of saturated aqueous sodium hydrogen carbonate (20 mL). Following separation, the aqueous layer was extracted with dichloromethane (3 × 50 mL). The combined organic layers were dried over magnesium sulfate, filtered, and the solvent was removed *in vacuo*. Column chromatography (SiO₂) with hexane / ethyl acetate (10:1) gave the product as a colourless oil (0.340 g, 29%).

¹H NMR (400 MHz, CDCl₃): δ = 1.41 (s, 3H, CH₃), 1.50-1.64 (m, 3H, CH₂, *CHH*), 1.95-2.04 (m, 1H, *CHH*), 2.25-2.29 (m, 2H, CH₂), 9.44 (s, 1H, CHO), 10.17 (s, 1H, CHO). ¹³C NMR (400 MHz, CDCl₃): δ = 17.7 (CH₃), 20.2 (C5), 24.6 (C6), 32.2 (C4), 55.5 (C3), 136.5 (C1), 150.0 (C2), 191.1 (C7), 199.0 (C8). IR (neat): ν max = 2944, 2873, 1735, 1680, 1613, 1460, 1191 cm⁻¹.

(±) 2,6-Dimethylcyclohex-1-en-1-yl formate

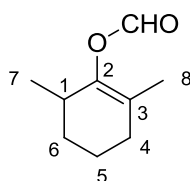

185

To a solution of *N,N*-dimethylformamide (1.84 mL, 23.8 mmol) in dry dichloromethane (50 mL) was added dropwise oxalyl chloride (2.01 mL, 23.8 mmol), at 0°C and the solution was stirred under argon for 1 hour, at this temperature, during which time the solution turned pale yellow. Then 2,6-dimethylcyclohexanone (1.00 g, 7.92 mmol) was added, and the reaction mixture was heated at reflux for 24 hours. The reaction was then diluted with dichloromethane (20 mL) and quenched by the addition of saturated aqueous sodium hydrogen carbonate (20 mL). Following separation, the aqueous layer was extracted with dichloromethane (3 × 50 mL). The combined organic layers were dried over magnesium sulfate, filtered, and the solvent was removed *in vacuo*. Column chromatography (SiO₂) with hexane / ethyl acetate (20:1) gave the product as a colourless oil (0.350 g, 29%).

¹H NMR (400 MHz, CDCl₃): δ = 0.94 (d, 3H, *J* = 4 Hz, CH₃), 1.32-1.38 (m, 1H, CHH), 1.47 (s, 3H, CH₃), 1.49-1.52 (m, 1H, CHH), 1.53-1.67 (m, 1H, CHH) 1.76-1.84 (m, 1H, CHH), 1.97-2.02 (m, 2H, CH₂), 2.27-2.38 (m, 1H, CH), 8.01 (s, 1H, CHO). ¹³C NMR (400 MHz, CDCl₃): δ = 16.6 (C8), 18.3 (C7), 20.2 (C5), 31.7 (C4) 31.8 (C6), 37.4 (C1), 121.5 (C3), 145.2 (C2), 159.8 (CHO). IR (neat): ν max = 2936, 2867, 1737, 1696, 1456, 1134 cm⁻¹.

3-Hydroxy-1H-indene-2-carbaldehyde

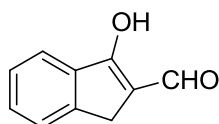

159

To a solution of *N,N*-dimethylformamide (5.08 mL, 65.7 mmol) in dry dichloromethane (20 mL) was added dropwise, oxalyl chloride (5.55 mL, 65.7 mmol), at 0°C and the solution was stirred under argon for 1 hour, at this temperature, during which time the solution turned pale

yellow. Then (1*H*-inden-3-yloxy)(trimethyl)silane (4.47 g, 21.9 mmol) was added, and the reaction mixture was stirred at room temperature for 24 hours. The reaction was then diluted with dichloromethane (30 mL) and quenched by the addition of saturated aqueous sodium hydrogen carbonate (20 mL). Following separation, the aqueous layer was extracted with dichloromethane (3 × 100 mL). The combined organic layers were dried over magnesium sulfate, filtered, and the solvent was removed *in vacuo*. Column chromatography (SiO₂) with hexane / ethyl acetate (20:1) gave the product as an orange solid. (50 mg, < 1%).

¹H NMR (400 MHz, CDCl₃): δ = 1.19 (s, 1H, OH), 3.63 (s, 2H, CH₂), 7.38-7.51 (m, 3H, ArH), 7.64 (d, 1H, *J* = 8 Hz, Ar) 10.18 (s, 1H, CHO). Literature data consistent with compound **159** was not found and the possible reason for this is discussed on page 69.

2-Hydroxycyclohexene-1-carbaldehyde

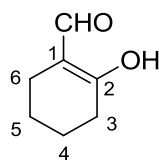

153

To a solution of *N,N*-dimethylformamide (0.27 mL, 3.52 mmol) in dry dichloromethane (10 mL) was added dropwise oxalyl chloride (0.30 mL, 3.52 mmol), 0°C and the solution was stirred under argon for 1 hour, at this temperature, at during which time the solution turned pale yellow. Then cyclohexen-1-yloxy(trimethyl)silane (0.200 g, 1.17 mmol) was added, and the reaction mixture was stirred at room temperature for 24 hours. The reaction was then diluted with dichloromethane (10 mL) and quenched by the addition of saturated aqueous sodium hydrogen carbonate (10 mL). Following separation, the aqueous layer was extracted with dichloromethane (3 × 50 mL). The combined organic layers were dried over magnesium sulfate, filtered, and the solvent was removed *in vacuo*. Column chromatography (SiO₂) with hexane / ethyl acetate (10:1) gave the product as a colourless oil (16 mg, 11%).

¹H NMR (400 MHz, CDCl₃): δ = 1.21 (s, 1H, OH), 1.58-1.79 (m, 4H, CH₂), 2.19-2.30 (m, 2H, CH₂), 2.48-2.59 (m, 2H, CH₂), 10.15 (s, 1H, CHO). This data differed with that reported in the literature for this compound, and this is discussed on page 68.

(Z)-3-Hydroxy-3-phenyl-prop-2-enal

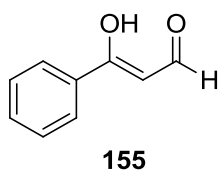

To a solution of *N,N*-dimethylformamide (2.98 mL, 38.5 mmol) in dry dichloromethane (50 mL) was added dropwise oxalyl chloride (3.26 mL, 38.5 mmol), at 0°C and the solution was stirred under argon for 1 hour, at this temperature, during which time the solution turned pale yellow. Then trimethyl(1-phenylvinyl)oxy)silane (2.47g, 12.8 mmol) was added, and the reaction mixture was stirred at room temperature for 24 hours. The reaction was then diluted with dichloromethane (20 mL) and quenched by the addition of saturated aqueous sodium hydrogen carbonate (20 mL). Following separation, the aqueous layer was extracted with dichloromethane (3 × 100 mL). The combined organic layers were dried over magnesium sulfate, filtered, and the solvent was removed *in vacuo*. Distillation at low pressure, with the use of a Kugelrohr apparatus, gave the product as a yellow oil. (457 mg, 24%)

¹H NMR (400 MHz, CDCl₃): δ = 6.64 (d, 1H, *J* = 8 Hz, CH), 7.36-7.55 (m, 3H, ArH), 7.65-7.79 (m, 2H, ArH), 10.19 (s, 1H, CHO). This data differed with that reported in the literature for this compound, and this is discussed on page 68.

(±) 2-(Benzylamino)methyl-2-methylindan-1-one

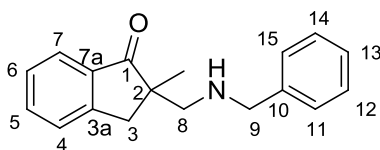

Crude 2-methyl-1-oxoindane-2-carbaldehyde, generated as described above from 2-methyl-1-indanone (0.210 g, 1.44 mmol), was dissolved in 1,2-dichloroethane (10 mL), and to the solution was added benzylamine (0.16 mL, 1.5 mmol), sodium triacetoxyborohydride (0.375 g, 1.8 mmol) and acetic acid (0.08 mL, 1.4 mmol), and the reaction mixture was stirred under argon for 2 hours at room temperature. The reaction was then quenched by the addition of saturated aqueous sodium hydrogen carbonate (20 mL). Following separation, the aqueous

layer was extracted with dichloromethane (3 × 100 mL). The combined organic fractions were dried over magnesium sulfate, filtered, and the solvent was removed *in vacuo*. Column chromatography (SiO₂) with 3% MeOH-CH₂Cl₂ gave the product as a light brown oil (0.150 g, 39%).

¹H NMR (400 MHz, CDCl₃): δ = 1.12 (3H, s, CH₃), 1.68 (s, 1H, NH), 2.56 (1H, d, *J* = 12 Hz, CMe-CHH-NH), 2.77 (1H, d, *J* = 17 Hz, CHH-Ar), 2.87 (1H, d, *J* = 12 Hz, CMe-CHH-NH CHH-Ph), 3.23 (1H, d, *J* = 17 Hz, CHH-Ar), 3.64 (1H, d, *J* = 12, CHH-Ph), 3.69 (1H, *J* = 12 Hz, CHH-Ph), 7.13–7.23 (5H, m, ArH), 7.28 (1H, t, *J* = 8 Hz, ArH), 7.37 (1H, d, *J* = 8 Hz, ArH), 7.51 (1H, t, *J* = 8 Hz, ArH), 7.66 (1H, d, *J* = 8 Hz, ArH). ¹³C NMR (300 MHz, CDCl₃): δ = 22.8 (CH₃), 39.4 (C3), 50.4 (C2), 54.5 (C8), 55.9 (C9), 124.4 (C4), 126.9 (C6), 127.1 (C7, C13), 127.5 (C12, C14), 128.2 (C11) 128.5 (C15), 135.1 (C7a), 136.4 (C5), 140.5 (C10), 153.7 (C3a), 211.3 (C1). IR (neat): ν max = 3329, 1702, 1607, 1453, 1292 cm⁻¹. HRMS (ES): *m/z* calcd for C₁₈H₂₀NO [MH⁺]: 266.1539; found: 266.1544.

(±) 2-[(Benzylamino)methyl]-2-methyl-3,4-dihydronaphthalen-1(2H)-one

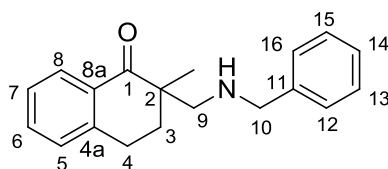

192

Crude 2-methyl-1-oxo-1,2,3,4-tetrahydronaphthalene-2-carbaldehyde, generated as described above from 2-methyl-1-tetralone (0.733 g, 4.58 mmol), was dissolved in 1,2-dichloroethane (10 mL), and to the solution was added benzylamine (0.50 mL, 4.58 mmol), sodium triacetoxyborohydride (1.45g, 6.86 mmol) and acetic acid (0.26 mL, 4.58 mmol), and the reaction mixture was stirred under argon for 2 hours at room temperature. The reaction was then quenched by the addition of saturated aqueous sodium hydrogen carbonate (20 mL). Following separation, the aqueous layer was extracted with dichloromethane (3 × 100 mL). The combined organic fractions were dried over magnesium sulfate, filtered, and the solvent was removed *in vacuo*. Column chromatography (SiO₂) with 1% MeOH-CH₂Cl₂ gave the product as a brown oil (0.307g, 24%).

^1H NMR (400 MHz, CDCl_3): δ = 1.19 (s, 3H, CH_3), 1.62 (s, 1H, NH), 1.72-1.84 (m, 1H, J $\text{CH}_2\text{-CHH-CMe}$), 2.35 (ddd, 1H, J = 15, 10, 5 Hz, $\text{CH}_2\text{-CHH-CMe}$), 2.49 (d, 1H, J = 12 Hz, CMe-CHH-NH), 2.82-3.02 (m, 2H, $\text{CH}_2\text{-CH}_2\text{-CMe}$), 2.95 (d, 1H, J = 12 Hz, CMe-CHH-NH), 3.70 (d, 1H, J = 12 Hz, CHH-Ph), 3.76 (d, 1H, J = 12 Hz, CHH-Ph), 7.17-7.39 (m, 7H, ArH), 7.38 (t, 1H, J = 8 Hz, ArH), 8.01 (d, 1H, J = 8 Hz, ArH). ^{13}C NMR (400 MHz, CDCl_3): δ = 20.6 (CH_3), 25.4 (C3), 32.3 (C4) 46.1 (C2), 54.5 (C10), 55.9 (C9), 126.6 (C7), 126.8 (C14), 127.9 (C5), 128.3 (C13, C15), 128.7 (C8a, C12, C16), 131.2, (C6) 133.2 (C8), 140.5 (C11), 143.5 (C4a), 202.7 (C1). IR (neat): ν max = 3334, 3062, 3026, 2926, 1674, 1600, 1453, 1220, 1096, 967, 899 cm^{-1} . HRMS (ES): m/z calcd for $\text{C}_{19}\text{H}_{21}\text{NO}$ [MH^+]: 280.1696; found 280.1698.

General procedure for the formylation of 2-methyl-1-tetralone in different solvents (as shown in Table 17, page 77).

To a solution of *N,N*-dimethylformamide (0.14 mL, 1.87 mmol) in 10 mL of dry solvent (dichloromethane, chloroform, diethyl ether, tetrahydrofuran, toluene) was added, dropwise, oxalyl chloride (0.16 mL, 1.87 mmol) and the solution was stirred under argon for 1 hour at 0 °C. Then 2-methyl-1-tetralone (100 mg, 0.62 mmol) was added and the reaction mixture was stirred at room temperature for 24 hours. The reaction was then diluted with dichloromethane (10 mL) and quenched by the addition of saturated aqueous sodium hydrogen carbonate (10 mL). Following separation, the aqueous layer was extracted with dichloromethane (3×50 mL). The combined organic layers were dried over magnesium sulfate, filtered, and the solvent was removed *in vacuo*. The crude material was then analysed by ^1H NMR spectroscopy to determine the percentage conversion to α -formyl ketone.

General procedure for the formylation of 2-methyl-1-tetralone with different iminium salts (as shown in Table 19, page 79).

To a solution of *N,N*-dimethylformamide (0.29 mL, 3.75 mmol) in dry dichloromethane (50 mL) was added 1 equivalent of an acid halide (oxalyl chloride, oxalyl bromide, phosphorus oxychloride, phosphorus oxybromide), and the solution was stirred under argon for 1 hour at 0 °C. Then 2-methyl-1-tetralone (200 mg, 1.25 mmol) was added and the reaction mixture was stirred at room temperature for 24 hours. The reaction was then diluted with dichloromethane (10 mL) and quenched by the addition of saturated aqueous sodium hydrogen carbonate (10

mL). Following separation, the aqueous layer was extracted with dichloromethane (3×50 mL). The combined organic layers were dried over magnesium sulfate, filtered, and the solvent was removed *in vacuo*. The crude material was then analysed by ^1H NMR spectroscopy to determine the percentage conversion to α -formyl ketone.

Competitive chloroenal vs. α -formylation experiment

To a solution of *N,N*-dimethylformamide (0.11 mL, 1.44 mmol) in dry dichloromethane (20 mL) was added, dropwise, oxalyl chloride (0.12 mL, 1.44 mmol), and the solution was stirred under argon for 1 hour at 0°C during which time the solution turned pale yellow. Then 2-methyl-1-indanone (0.210 g, 1.44 mmol) and 1-indanone (0.190 g, 1.44 mmol), in a solution of dichloromethane (5 mL), were added and the reaction mixture stirred at room temperature for 24 hours. The reaction was then diluted with dichloromethane (10 mL) and quenched by the addition of saturated aqueous sodium hydrogen carbonate (10 mL). Following separation, the aqueous layer was extracted with dichloromethane (3×50 mL). The combined organic layers were dried over magnesium sulfate, filtered, and the solvent was removed *in vacuo*. The crude material was analysed by ^1H NMR spectroscopy to determine the ratio of two products, the chloroenal (of 1-indanone) and the α -formyl ketone of (2-methyl-1-indanone).

Experiment aimed at detecting carbon monoxide during the decarbonylation of 2-methyl-1-oxoindane-2-carbaldehyde.

Compound **170** (2-methyl-1-oxo-1,2,3,4-tetrahydronaphthalene-2-carbaldehyde) (0.300 g, 1.59 mmol), was dissolved in deuterated chloroform (5 mL) in a two necked round bottomed flask, which was connected, *via* a tube, to an air tight plastic bag containing an electronic carbon monoxide detector. Then to the solution was added 2.0 g of silica and the mixture stirred at room temperature for 1 hour, during which time the carbon monoxide detector did not sound. An aliquot of the mixture was then filtered through cotton wool, to remove silica, and analysed by ^1H NMR spectroscopy, which indicated that complete decarbonylation had been achieved. A control experiment was also conducted where the carbon monoxide detector was connected to a flask containing a solution of (0.1 eq) of DMF in dichloromethane, to which was added (0.1 eq) oxalyl chloride and the reaction mixture stirred at room temperature. The carbon monoxide detector sounded about 10 seconds after the reaction had been initiated.

Experiment aimed at detecting formic acid during the decarbonylation of 2-methyl-1-oxoindane-2-carbaldehyde.

Compound **170** (2-methyl-1-oxo-1,2,3,4-tetrahydronaphthalene-2-carbaldehyde) was dissolved in deuterated chloroform, under argon. Then silica was added and the mixture stirred at room temperature for 1 hour. A small aliquot of the mixture was then filtered through cotton wool, to remove silica, and analysed by ^1H NMR spectroscopy, which indicated that complete decarbonylation had occurred, however no peak corresponding to formic acid was observed. Then a second solution containing toluene (added as an internal standard) and formic acid, of the same molarity as the α -formyl ketone solution, was added to the first solution and the solution stirred for an additional 1 hour. A second aliquot was then filtered through cotton wool and analysed by ^1H NMR. The spectrum clearly showed the formamide proton of formic acid as a singlet at 7.97 ppm, and the methyl protons of toluene as a singlet at 2.26 ppm, as well as signals corresponding to the decarbonylated compound *i.e.* the α -formyl ketone. A control experiment where no silica was added (under otherwise identical conditions) indicated that no decarbonylation had occurred when silica was not present.

Experiment aimed at investigating the role of light in the decarbonylation of 2-methyl-1-oxo-1,2,3,4-tetrahydronaphthalene-2-carbaldehyde

Equal amounts (100 mg) of a crude sample containing a mixture of α -formyl ketone **170** and 2-methyl-1-tetralone **161**, in the approximate ratio 64% : 36 % respectively, were placed in four separate reaction vessels and to them was added *d*-chloroform (5 mL) and a spatula of silica (except for the control experiment where no silica was added). The reaction mixtures were then stirred for 30 mins, and then aliquots of the sample mixtures were filtered through cotton wool to remove silica, and analysed by ^1H NMR spectroscopy. More samples were taken after 24 hours and analysed in the same way.

Experimental of chapter 3

N-formyl-(*S*)-proline methyl ester

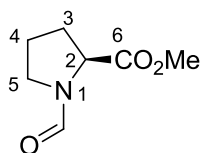

149

(*S*)-Proline (6.00 g, 52.1 mmol) was dissolved in methanol (50 mL) and the solution cooled to 0°C in an ice bath. Then thionyl chloride (4.18 mL, 57.3 mmol) was added dropwise, and the solution stirred for 10 mins. The reaction mixture was then heated at reflux for 24 hrs. The solvent and excess thionyl chloride were then removed *in vacuo*. The residue, (*S*)-proline methyl ester hydrochloride, was dissolved in dichloromethane (50 mL) and to the solution was added 1 equivalent of triethylamine (7.26 mL, 52.1 mmol) and the reaction mixture stirred for 10 mins. The solvent was then removed *in vacuo*, and the solid residue dissolved in formic acid (50 mL). The solution was then cooled to 0°C in an ice bath, and then acetic anhydride (5 mL) was added, and the reaction mixture stirred for 1 hour. The solvent was then removed *in vacuo* and saturated sodium hydrogen carbonate (20 mL) was added followed by extraction with dichloromethane (3x100 mL). The organic fractions were then combined, dried over magnesium sulfate and the solvent removed *in vacuo* to afford the crude material as a pale yellow oil. An analytical sample was distilled at low pressure, using a Kugelrohr apparatus, to afford the pure product as a colourless oil (6.61 g, 81%).

¹H NMR (400 MHz, CDCl₃): δ = 1.76-1.93 (m, 3H), 2.03-2.17 (m, 1H), 3.35-3.56 (m, 2H, NCH₂), 3.58 (s, 0.6H, OCH₃), 3.61 (s, 0.4H, OCH₃), 4.30 (ddd, *J* = 16, 8, 4 Hz, CHN), 8.08 (s, 0.4H, NCHO), 8.12 (s, 0.6H, NCHO). ¹³C NMR (400 MHz, CDCl₃): δ = 24.7 (C4), 29.3 (C3), 43.7 (C5) 46.2 (C2), 52.4 (CH₃), 56.3 (C2), 60.0 (C4), 160.7, 161.6 (CHO), 172.0, 172.2 (C6). IR Data: (neat) ν_{max} 3439, 2962, 2897, 2101, 1731, 1652, 1439, 1390, 1297, 1182, 526 cm⁻¹. HRMS (ES) *m/z* calcd for C₇H₁₁NO₃: 158.0812; found: 158.0809. [α]_D²² -12.9 (*c* 0.6, CHCl₃). This data was in agreement with that reported in the literature for this compound.¹¹⁸

Ethyl 2-[hydroxy(diphenyl)methyl]pyrrolidine-1-carboxylate

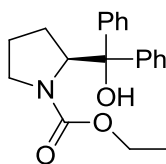

214

1-Ethyl 2-methyl-(2*S*)-pyrrolidine-1,2-dicarboxylate (5.87 g, 29.2 mmol) was placed in a two necked round bottomed flask and to it was added a solution containing phenyl magnesium bromide (72.9 mL, 72.9 mmol, of a 1M solution in THF) through a septum, under argon at 0°C. The reaction mixture was quenched by the addition of saturated ammonium chloride (60 mL). The supernatant liquid was decanted leaving behind a white precipitate and the precipitate was stirred with chloroform (2 x 60 mL). The organic extract was collected and washed with water (120 mL) and then brine (120 mL). The organic layer was then collected, dried over magnesium sulfate, filtered, and the solvent was then removed *in vacuo* to afford a pale yellow liquid which was purified by column chromatography (hexane/ethyl acetate 2:1) to give the product as a white crystalline solid (2.66 g, 28%).

¹H NMR (400MHz, CDCl₃): δ = 0.68-0.84 (m, 1H, CHH), 1.20 (3H, m, *J* = 8 Hz, CH₂CH₃), 1.41-1.51 (m, 1H, CHH), 1.52 (s, 1H, OH), 1.83-1.97 (m, 1H, CHH), 2.01-2.16 (m, 1H, CHH), 2.81-2.96 (m, 1H, NCHH), 3.32-3.41 (m, 1H, NCHH), 4.11 (q, 2H, *J* = 8 Hz, CH₂CH₃), 4.88 (dd, 1H, *J* = 8, 4 Hz, NCH), 7.18-7.40 (m, 10H, ArH). This data was in agreement with that reported in the literature for this compound.¹¹⁹

Methyl (*S*)-1-benzylpyrrolidine-2-carboxylate

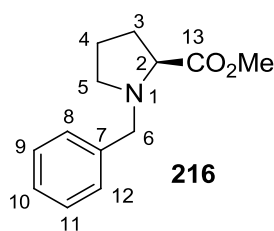

(*S*)-Proline (20.0 g, 173.7 mmol) was dissolved in methanol (50 mL) and the solution cooled to 0°C in an ice bath. Then thionyl chloride (13.9 mL, 191.1 mmol) was added dropwise, and the solution stirred for 10 mins. The reaction mixture was then heated at reflux for 24 hrs. The solvent and excess thionyl chloride were then removed *in vacuo*. The residue, (*S*)-proline methyl ester hydrochloride, was dissolved in toluene (200 mL) and to the solution was added triethylamine (121 mL, 868 mmol) and the reaction mixture stirred at room temperature for 10 mins. The reaction mixture was then cooled to 0°C in an ice bath, then benzyl bromide (22.7 ml, 191.1 mmol) was added and the biphasic mixture refluxed for 24 hours. The reaction mixture was then allowed to cool to room temperature and quenched with saturated sodium hydrogen carbonate (50 mL). The toluene was then removed *in vacuo*, and the remaining aqueous fraction was extracted with ethyl acetate (3 x 100 mL). The organic fractions were then combined, dried over magnesium sulfate, and the solvent removed *in vacuo* to afford the product as an orange oil (32.0 g, 84%). Spectroscopic analysis indicated that the material was pure enough to use for the next step without further purification.

¹H NMR (400 MHz, CDCl₃): δ = 1.66-1.75 (1H, m, NCH₂CHH), 1.80-1.93 (2H, m, NCHCHH and NCH₂CHH), 2.02-2.13 (1H, m, NCHCHH), 2.27-2.39 (1H, m, NCHHCH₂), 2.96-3.02 (1H, m, NCHHCH₂), 3.19 (1H, dd, *J* = 8, 4 Hz, CHN), 3.51 (1H, d, *J* = 16 Hz, PhCHH), 3.59 (3H, s, CH₃), 3.83 (1H, d, *J* = 16 Hz, PhCHH), 7.18-7.28 (5H, m, ArH). ¹³C NMR (400 MHz, CDCl₃): δ = 23.0 (C4), 29.2 (C3), 51.4 (CH₃), 53.1 (C5), 58.4 (C6), 65.1 (C2), 127.0 (C10), 128.3 (C9, C11), 129.1 (C8, C12), 138.4 (C7), 174.3 (C13). IR Data: (neat) ν_{max} 3444, 3027, 2800, 2877, 1735, 1644, 1453, 1376, 1205, 1179, 744, 700 cm⁻¹. HRMS (ES) *m/z* calcd for C₁₃H₁₇NO₂ [MH]⁺: 220.1332; found: 220.1331. This data was in agreement with that reported in the literature for this compound.¹²²

(S)-(1-Benzylpyrrolidin-2-yl)diphenylmethanol

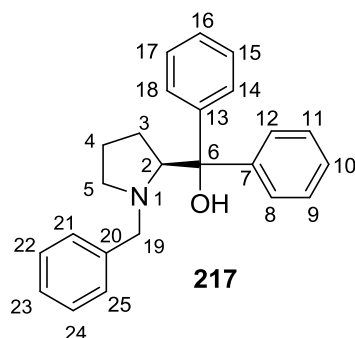

A 500 mL round bottomed flask was charged with magnesium turnings (8.90 g, 366.0 mmol), dry tetrahydrofuran (150 mL) and a few crystals of iodine, under an argon atmosphere. Bromobenzene (12.9 mL, 122.5 mmol) was then added by syringe and the flask warmed with a heat gun to initiate the reaction. The remaining bromobenzene (25.6 mL, 243.5 mmol) was added over a period of 30 mins and the reaction mixture was stirred vigorously for 1 hour and then allowed to cooled to room temperature. Then methyl (S)-1-benzylpyrrolidin-2-carboxylate (32.0 g, 146.0 mmol), obtained from the previous step, was added gradually and the reaction mixture stirred for 10 mins during which time it refluxed in its own heat, and the reaction was then heated at reflux for 2 hours to drive it to completion. The reaction mixture was then cooled to 0°C in an ice bath, and quenched by the slow addition of 1M hydrochloric acid (100 mL). The tetrahydrofuran was then removed *in vacuo* and to the residue, an orange slurry, was added diethyl ether (100 mL) and the mixture stirred for a further 2 hours. The resulting precipitate was isolated by filtration and then dissolved in a mixture of ethyl acetate (100 mL) and saturated sodium hydrogen carbonate (100 mL). The phases were separated and the aqueous layer was extracted with ethyl acetate (2 x100 mL), and the organic layers were then combined and washed with brine (100 mL). The organic layer was then collected, dried over magnesium sulfate, and the solvent removed *in vacuo* to afford the crude material as a dark orange solid, which was recrystallised from ethanol to give the pure product as an off white solid (48.8 g, 97%).

^1H NMR (400 MHz, CDCl_3): δ = 1.51-1.62 (2H, m, NCH_2CH_2), 1.65-1.73 (1H, m, NCHCHH), 1.84-1.94 (1H, m, NCHCHH), 2.24-2.32 (1H, m, NCHHCH_2), 2.81-2.87 (1H, m, NCHHCH_2), 2.95 (1H, d, J = 12 Hz, PhCHH), 3.15 (1H, d, J = 12 Hz, PhCHH), 3.91 (1H, dd, J = 12, 4 Hz, CHN), 4.83 (1H, s, OH), 6.95-7.24 (11H, m, ArH), 7.51 (2H, d, J = 8 Hz), 7.65 (2H, d, J = 8 Hz). ^{13}C NMR (400 MHz, CDCl_3): δ = 24.3 (C4), 29.9 (C3), 55.6 (C5), 60.7 (C19), 70.7 (C2), 78.1 (C6) 125.6, 125.7 (C9, C15, C17), 126.3, 126.5 (C8, C11, C14, C18), 126.9 (C10, C16,

C24), 128.1, 128.2 (C21, C25), 128.3, 128.7 (C22, C24), 139.7 (C20), 148.1, 148.3 (C7, C13). IR Data: (neat) ν_{\max} 3322, 3059, 3027, 2801, 2160, 1660, 1599, 1494, 1447, 1372, 1030, 746, 697 cm^{-1} . $[\alpha]_{\text{D}}^{22} +64.0$ (c 0.01, CHCl_3). This data was in agreement with that reported in the literature for this compound.¹²²

(S)-(-)-1-Benzyl-2-(1-methoxy-1,1-diphenylmethyl)-pyrrolidine

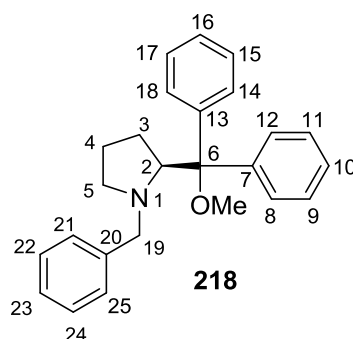

(S)-(1-Benzylpyrrolidin-2-yl)diphenylmethanol (26.0 g, 75.7 mmol) was dissolved in dry tetrahydrofuran, under argon, and the solution cooled to -30°C . Then methyl iodide (14.1 mL, 227.1 mmol) and sodium hydride (2.73 g, 113.6 mmol) were added and the reaction was allowed to warm to room temperature. The reaction mixture was then refluxed for 6 days under argon during which time a grey solid precipitated. Then saturated ammonium chloride (20 mL) was added and the layers separated. The aqueous layer was then extracted with diethyl ether (2 x 100 mL) and the combined organic layers washed with saturated sodium hydrogen carbonate (2 x 50 mL). The organic layer was then collected, dried over magnesium sulfate, and the solvent removed *in vacuo* to give the crude material. Column chromatography (SiO_2) with 5% EtOAc-hexane gave the product as a pale orange solid (17.6 g, 65%).

^1H NMR (400 MHz, CDCl_3): δ = 0.37-0.49 (1H, m, NCH_2CHH), 1.23-1.44 (1H, m, NCH_2CHH), 1.77-1.84 (1H, m, NCHCHH), 1.96-2.04 (1H, m, NCHCHH), 2.08-2.25 (1H, m, NCHH), 2.46-2.58 (1H, m, NCHH), 2.97 (3H, s, OCH_3), 3.46 (1H, d, $J = 16$ Hz, PhCHH), 3.99 (1H, dd, $J = 8, 4$ Hz, NCH), 4.26 (1H, d, $J = 16$ Hz, PhCHH), 7.18-7.41 (11H, m, ArH), 7.64-

7.68 (4H, m, ArH). ^{13}C NMR (400 MHz, CDCl_3): δ = 23.73 (C4), 29.0 (C3), 54.0 (CH_3), 52.2 (C5), 62.1 (C19), 70.5 (C2), 87.5 (C6), 127.4 (C8, C12, C14, C18), 127.6 (C9, C11, C15, C17), 128.3 (C10, C16, C22, C24), 130.4 (C23), 130.5 (C21, C25), 139.5 (C20), 140.4 (C7, C13). IR Data: (neat) ν_{max} 3057, 3025, 2941, 2823, 2159, 1601, 1494, 1447, 1071, 759, 701 cm^{-1} . This data was in agreement with that reported in the literature for this compound.¹²³

2-[Methoxy(diphenyl)methyl]pyrrolidine-1-carbaldehyde

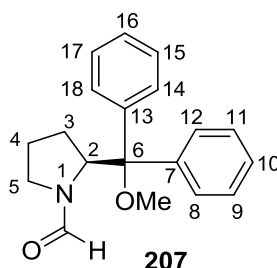

(*S*)-(-)-1-Benzyl-2-(1-methoxy-1,1-diphenylmethyl)-pyrrolidine (17.6, 49.2 mmol) was dissolved in methanol (250 mL) and to the solution were added ammonium formate (31.0g, 492.0 mmol) and palladium hydroxide (on carbon) (0.691g, 4.92 mmol) and the reaction mixture was heated at reflux for 3 days, under an argon atmosphere. The reaction was cooled to room temperature and filtered to remove charcoal. The solvent was then removed *in vacuo* to afford a crude material which contained a mixture of (2*S*)-2-[methoxy(diphenyl)methyl]pyrrolidine and its *N*-formylated analog. This mixture was dissolved in formic acid (100 mL) and cooled to 0°C. Acetic anhydride (10 mL) was added and the reaction mixture was allowed to warm to room temperature with stirring. The solvent was then removed *in vacuo* and the residue dissolved in dichloromethane (200 mL) and washed with saturated sodium hydrogen carbonate (2 x 50 mL). The organic layer was then collected, dried over magnesium sulfate, and the solvent removed *in vacuo* to afford the crude material. Column chromatography (SiO_2) with 10% EtOAc-hexane gave the product as a dark purple oil (11.34g, 78%).

^1H NMR (400 MHz, CDCl_3): δ = 0.63-0.74 (m, 1H, NCH_2CHH), 1.31-1.42 (m, 1H, NCH_2CHH), 1.82-1.91 (m, 1H, NCHCHH), 2.05-2.16 (m, 2H, NCHH , NCHCHH), 2.83 (s, 3H, OCH_3), 3.29-3.38 (m, 1H, NCHH), 4.82 (dd, 1H, J = 8, 4 Hz NCH), 7.25-7.34 (m, 10H, ArH), 8.33 (s, 1H, NCHO). ^{13}C NMR (400 MHz, CDCl_3): δ = 22.2 (C4), 27.5 (C3), 44.5 (C5), 51.8 (CH_3), 63.8 (C2), 85.9 (C6), 128.0 (C8, C12, C14, C18), 128.3 (C10, C16), 130.0

(C9, C11, C15, C17), 132.5 (C7, C13), 163.7 (CHO). IR Data: (neat) ν_{\max} 3057, 2944, 2887, 2826, 1663, 1494, 1447, 1421, 1390, 1072, 762, 705 cm^{-1} . HRMS (ES) m/z calcd for $\text{C}_{19}\text{H}_{21}\text{NO}_2$ $[\text{MH}]^+$: 296.1645; found: 296.1649. $[\alpha]_{\text{D}}^{22}$ - 4.2 (*c* 1.3, CHCl_3).

(S)-2-[Fluoro(diphenyl)methyl]pyrrolidine-1-carbaldehyde

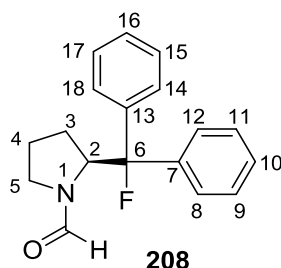

(S)-Diphenyl(pyrrolidin-2-yl)methanol (1.00 g, 3.95 mmol) was dissolved in dry dichloromethane (10 mL), under argon, and the solution cooled to 0°C. Then diethyl ammonium suflur trichloride (DAST) (0.52 mL, 3.95 mmol) was added over a period of 1 min, with stirring, and the solution allowed to warm to room temperature. The reaction mixture was then diluted with dichloromethane (50 mL), the layers separated, and the aqueous phase extracted with more dichloromethane (3 x 50 mL). The combined organic fractions were then dried over magnesium sulfate and the solvent removed *in vacuo*. The residue was then dissolved in formic acid (50 mL) and the solution cooled to 0°C. Acetic anhydride (5 mL) was then added and the reaction mixture warmed to room temperature. The solvent was then removed *in vacuo* and the residue dissolved in dichloromethane (50 mL) and washed with saturated sodium hydrogen carbonate (2 x 10 mL). The organic fraction was then collected, dried over magnesium sulfate and the solvent removed *in vacuo* to give the crude material. Column chromatography (SiO_2) with 1:1 EtOAc-hexane gave the product as a dark brown solid (600 mg, 54%).

^1H NMR (400 MHz, CDCl_3): δ = 1.65-1.83 (m, 2H, NCH_2CH_2), 1.89-2.18 (m, 2H, NCHCH_2), 3.18-3.24 (m, 1H, NCHH), 3.63-3.72 (m, 1H, NCHH), 4.64 (ddd, 1H, $J_{\text{H,F}} = 25$ Hz, $J = 8, 4$ Hz, NCH), 7.14-7.36 (m, 11H, Ar-H and NCHO). ^{13}C NMR (400 MHz, CDCl_3): δ = 22.9 (C4), 27.9 (C3), 46.1 (C5), 47.7 (C5), 64.1 (C2), 100.2 (C6), 102.3 (C6), 125.6, 125.8 (C8, C12, C14, C18), 125.9 (C10, C16), 126.0, 128.5 (C9, C11, C15, C17), 140.9 (C7, C13), 163.3 (CHO). IR Data: (neat) ν_{\max} 2889, 1655, 1494, 1449, 1386, 1352, 1265, 1028, 986, 900 cm^{-1} .

HRMS (ES) m/z calcd for $C_{18}H_{18}FNO$ $[MH]^+$: 284.1445; found: 284.1445. $[\alpha]_D^{22} + 4.2$ (c 0.2, $CHCl_3$).

General procedure for the preparation of α -formyl ketones and subsequent reductive amination

The formamide (1.5 eq) is dissolved in dichloromethane and the solution cooled to 0°C , followed by the addition of oxalyl chloride (1.5 eq), and stirred for 1 hour. The ketone (200 mg, 1 eq) is then added and the reaction stirred at a given temperature and reaction time, under an argon atmosphere. The reaction mixture is then allowed to reach room temperature and quenched by the addition of saturated sodium hydrogen carbonate (10 mL) followed by extraction into dichloromethane (3 x 50 mL). The combined organic fractions are then dried over magnesium sulfate and the solvent removed *in vacuo* to give the crude α -formyl ketone. This is then dissolved in 1,2-dichloroethane (10 mL) and to the solution is added (*S*)-(-)- α -methyl benzylamine (1.5 eq.), sodium triacetoxyborohydride (1.5 eq.) and acetic acid (1 eq.) and the solution stirred at room temperature for 2 hours under an argon atmosphere. The reaction is then quenched by the addition of saturated sodium hydrogen carbonate (10 mL) followed by extraction with dichloromethane (3 x 50 mL). The combined organics are then dried, over magnesium sulfate, filtered, and the solvent removed *in vacuo* to give the crude material, which is assayed by ^1H NMR spectroscopy to determine the ratio of two diastereoisomers. In the control reactions DMF was used as the formamide, in otherwise identical conditions. Although complete isolation and characterisation of the major diastereoisomers was not achieved, the ^1H NMR signals corresponding to the major diastereoisomers were observable and are reported below, and high resolution mass spectrometry of the crude materials confirmed the presence of the expected product.

2-Methyl-2-[[1-(1-phenylethyl)amino]methyl]indan-1-one

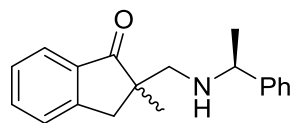

224

Major diastereoisomer:

^1H NMR (400 MHz, CDCl_3): 1.04 (s, 3H, CH_3), 1.20 (d, 3H, $J = 8$ Hz, PhCHCH_3), 2.47 (d, 1H, $J = 12$ Hz, NCHH), 2.61 (d, 1H, $J = 12$ Hz, NCHH), 2.80 (d, 1H, $J = 16$ Hz, CHH), 3.17 (d, 1H, $J = 16$ Hz, CHH), 3.60 (q, 1H, $J = 8$ Hz, PhCHCH_3), 7.12-7.35 (m, 7H, ArH), 7.49 (t, 1H, $J = 8$ Hz, ArH), 7.65 (d, 1H, $J = 8$ Hz, ArH). HRMS (ES) m/z calcd for $\text{C}_{19}\text{H}_{21}\text{NO}$ $[\text{MH}]^+$: 280.1696; found: 280.1697.

2-Methyl-2-[[1-(1-phenylethyl)amino]methyl]-3,4-dihydronaphthalen-1(2H)-one

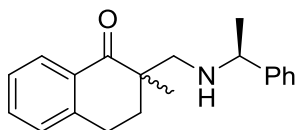

225

Major diastereoisomer:

^1H NMR (400 MHz, CDCl_3): $\delta =$ 1.17 (s, 3H, CH_3), 1.22 (d, 3H, $J = 8$ Hz, PhCHCH_3), 1.76 (dt, 1H, $J = 16, 4$ Hz, CHH), 2.27 (m, 1H, CHH), 2.41 (d, 1H, $J = 16$ Hz, NCHH), 2.62 (d, 1H, $J = 16$ Hz, NCHH), 2.73- 2.98 (m, 2H, CH_2), 3.67 (q, 1H, $J = 4$ Hz, CH_3CH), 7.05-7.23 (m, 7H, ArH), 7.37 (t, 1H, $J = 8$ Hz, ArH) 7.93 (d, 1H, $J = 8$ Hz, ArH). HRMS (ES) m/z calcd for $\text{C}_{20}\text{H}_{23}\text{NO}$: $[\text{MH}]^+$: 294.1852; found: 294.1857.

Experimental of Chapter 4

4-(2-Methyl-3,4-dihydronaphthalen-1-yl)morpholine

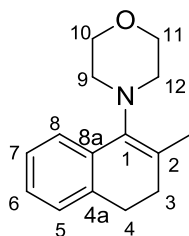

226

2-Methyl-1-tetralone (0.430 g, 2.68 mmol) was dissolved in benzene (5 mL) under an argon atmosphere, at 0°C in an ice bath. Then to the solution was added morpholine (1.17 mL, 13.4 mmol) in a solution of benzene (5 mL), and TiCl₄ (1.89 mL of 1M solution in dichloromethane, 1.89 mmol) and the reaction mixture was heated at 50°C for 3 hours, and then at room temperature for 24 hours. Diethyl ether (10 mL) was then added and the reaction mixture stirred for a further 30 minutes. The solvents were then removed *in vacuo* and the residue was chromatographed (SiO₂) in dichloromethane to afford the product as a yellow oil (0.363 g, 59%).

¹H NMR (400 MHz, CDCl₃): δ = 1.48 (s, 3H, CH₃), 2.17 (t, 2H, *J* = 8 Hz, CH₂), 2.64 (t, 2H, *J* = 8 Hz, CH₂), 3.01 (t, 4H, *J* = 4 Hz, N(CH₂)₂), 3.72 (t, 4H, *J* = 4 Hz, O(CH₂)₂), 7.01-7.20 (m, 3H, ArH), 7.45 (d, 1H, *J* = 8 Hz, ArH). ¹³C NMR (400 MHz, CDCl₃): δ = 18.6 (CH₃), 27.8 (C4), 30.0 (C3), 41.6, 49.2 (C9, C12), 65.9 (C10, C11), 122.0 (C8), 125.0 (C1), 126.2 (C7), 129.7 (C6), 135.7 (C2, C5, C8a), 138.8 (C4a). This data was in agreement with that reported in the literature for this compound.¹²⁸

General procedure for the preparation of 2-phenyl-*N*-(1-phenylethyl)propanamide

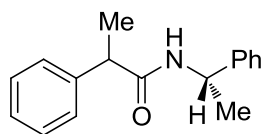

231

Racemic 2-phenylpropanoic acid is dissolved in dichloromethane (5 mL) and to the solution is added the chiral formamide (5 mL, 10 mol %, from a stock solution in dichloromethane) and then oxalyl chloride (0.6 eq.) is added dropwise to the solution, and the reaction mixture stirred for 1 hour at a certain temperature and reaction time. Then (*S*)-(-)- α -methylbenzylamine (1 eq.) is added and the reaction mixture stirred for an additional 1 hour. The reaction is then quenched by the addition of saturated sodium hydrogen carbonate (10 mL) followed by extraction with dichloromethane (3 x 50 mL). The organic layer is then collected, dried over magnesium sulfate, filtered, and the solvent removed *in vacuo* to give the crude material, which is analysed by ^1H NMR spectroscopy to determine the ratio of two diastereoisomers.

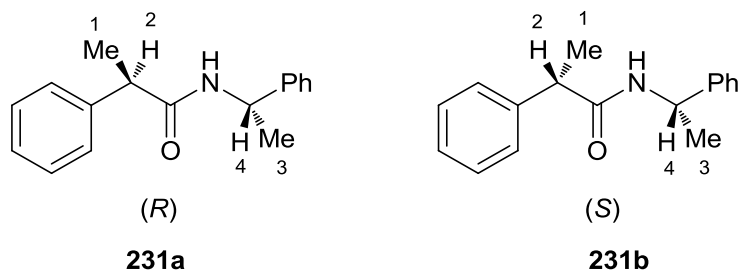

(2*R*)-2-Phenyl-*N*-[(1*S*)-1-phenylethyl]propanamide 231a

^1H NMR (400 MHz, CDCl_3): δ = 1.36 (d, 3H, J = 7 Hz, CH_3), 1.52 (d, 3H, J = 7 Hz, NCHCH_3), 3.56 (q, 1H, J = 7 Hz, CH), 5.05 (q, 1H, J = 7 Hz, NCH), 5.50 (s, 1H, NH), 7.19-7.41 (m, 10H, ArH). This data was in agreement with that reported in the literature for this compound.¹³⁰

(2*S*)-2-Phenyl-*N*-[(1*S*)-1-phenylethyl]propanamide 231b

¹H NMR (400 MHz, CDCl₃): δ = 1.32 (d, 3H, *J* = 7 Hz, CH₃), 1.52 (d, 3H, *J* = 7 Hz, CH₃), 3.52 (q, 1H, *J* = 7 Hz, CH), 5.01 (q, 1H, *J* = 7 Hz, NCH), 5.62 (s, 1H, NH), 7.17-7.41 (m, 10H, ArH). This data was in agreement with that reported in the literature for this compound.¹³⁰

Experiment aimed at the kinetic resolution of 1-phenylethanol

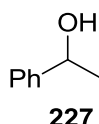

To a solution of *N*-formyl-(*S*)-proline methyl ester (0.515 g, 3.27 mmol) in dry dichloromethane (50 mL) was added, dropwise, oxalyl chloride (0.17 mL, 1.96 mmol) at 0°C, and the solution stirred under argon at that temperature for 1 hour at during which time the solution turned pale yellow. Then 1-phenylethanol (0.400 g, 3.27 mmol) was added and the reaction mixture stirred for 1 hour at 0°C. The reaction was then quenched by the addition of saturated sodium hydrogen carbonate (10 mL) followed by extraction with dichloromethane (3 x 50 mL). The organic layer was then collected, dried over magnesium sulphate, filtered, and the solvent removed *in vacuo* to give a mixture containing unreacted 1-phenylethanol and (1-chloroethyl)benzene, from which the 1-phenylethanol was isolated by chromatography (hexane-ethyl acetate 5:1) and analysed by chiral HPLC (5% isopropyl alcohol in hexane) to determine the ratio of two enantiomers. The trace indicated that the two enantiomers were present in a 1:1 ratio.

APPENDIX 1
(page 113).

¹H NMR spectrum of chloroiminium salt **150** in deuterated chloroform

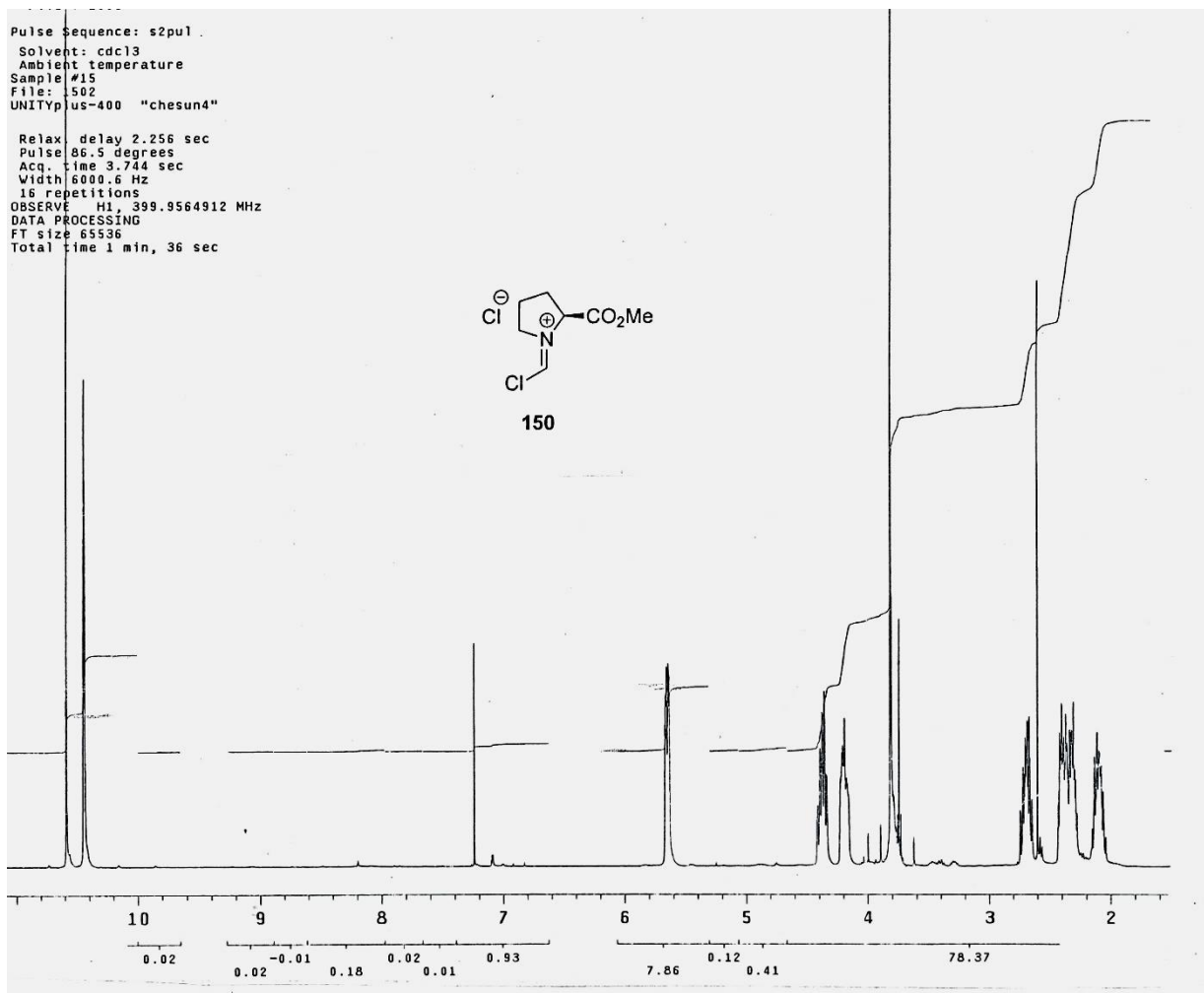

APPENDIX 2 ^1H NMR spectrum of crude product corresponding to data in entry 3 of Table 22 (page 137).

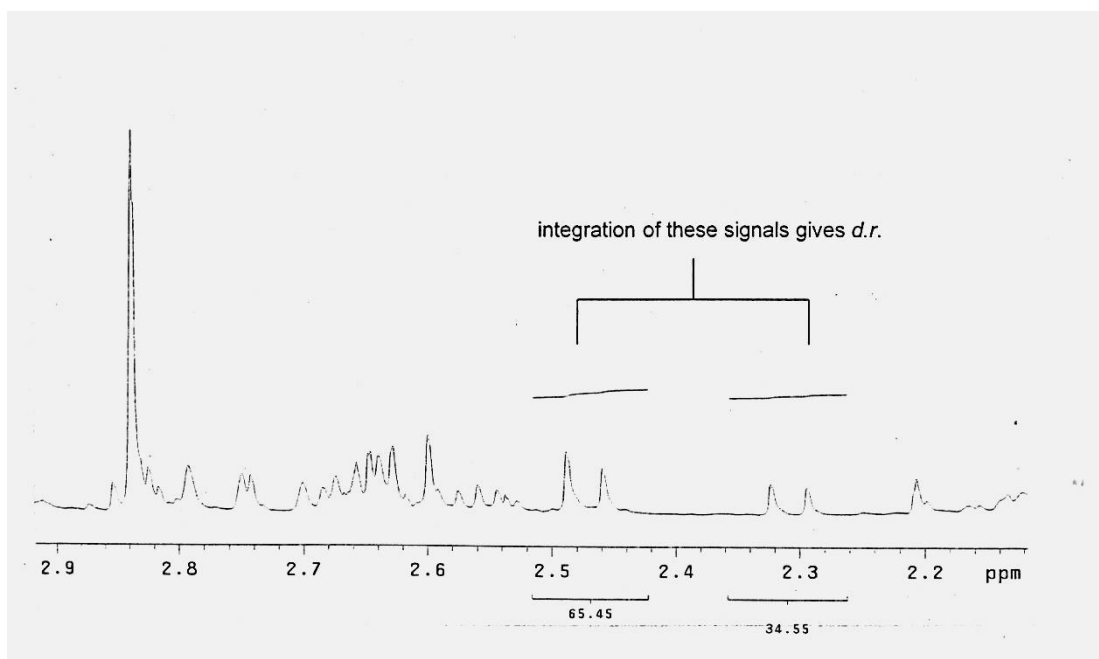
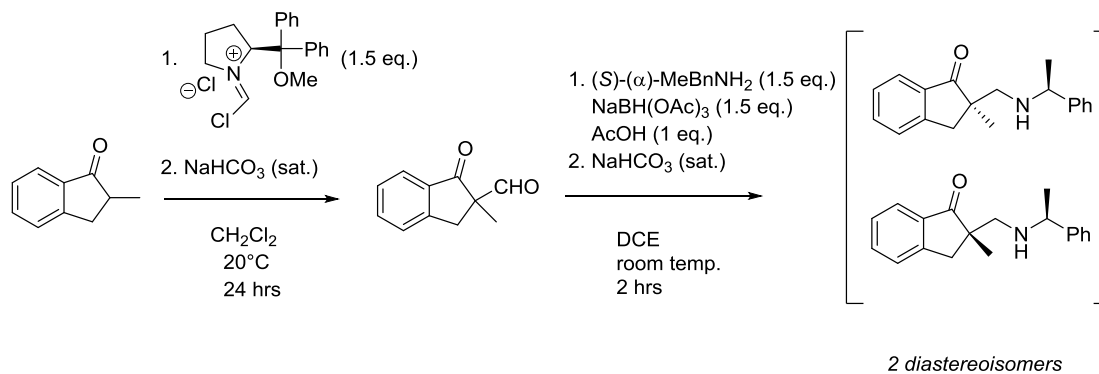

APPENDIX 3 ^1H NMR spectrum of crude product corresponding to data in entry 7 of Table 22 (page 137).

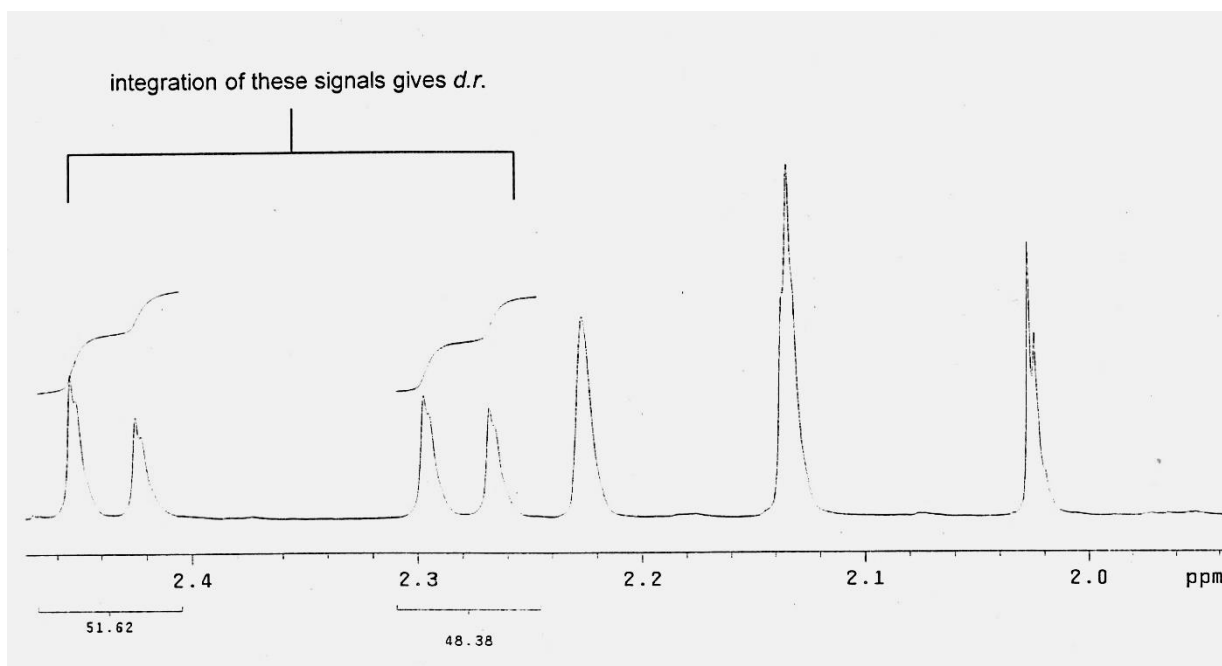
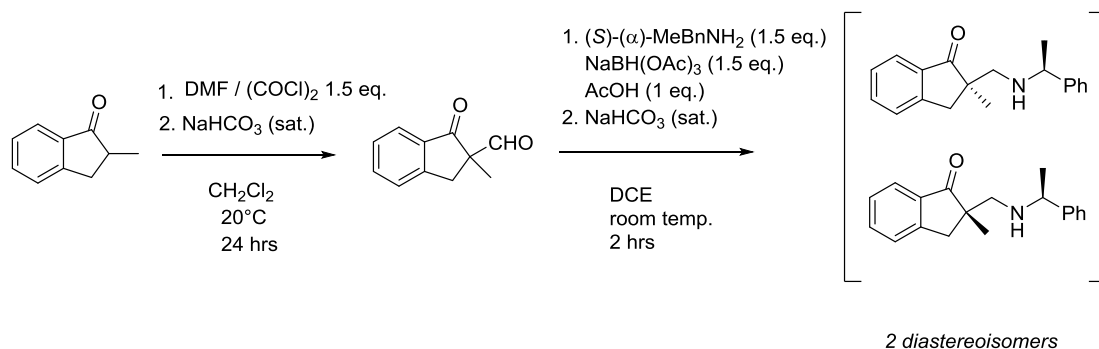

APPENDIX 4 ^1H NMR spectrum of crude product corresponding to data in entry 5 of Table 23 (page 138)

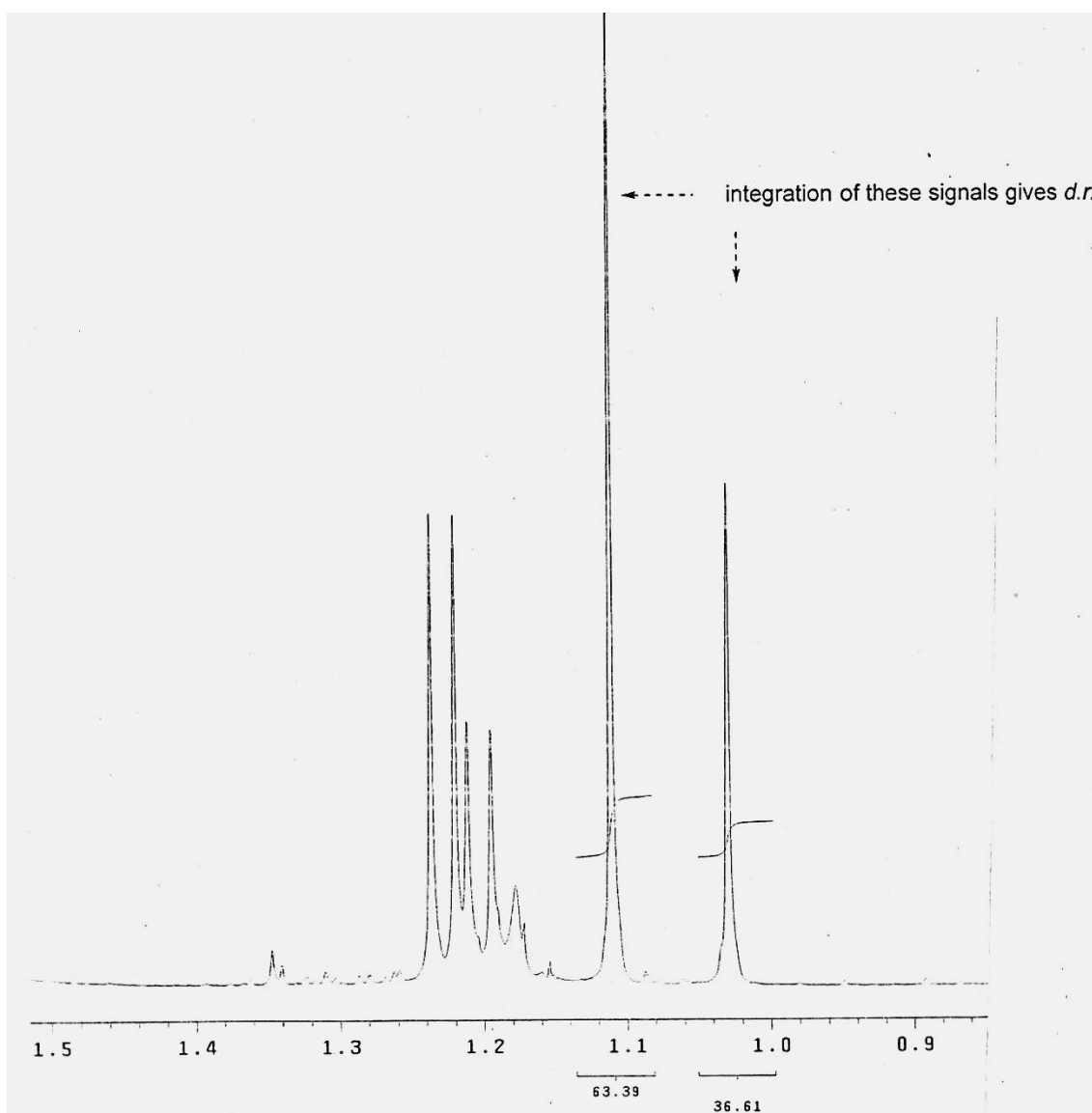
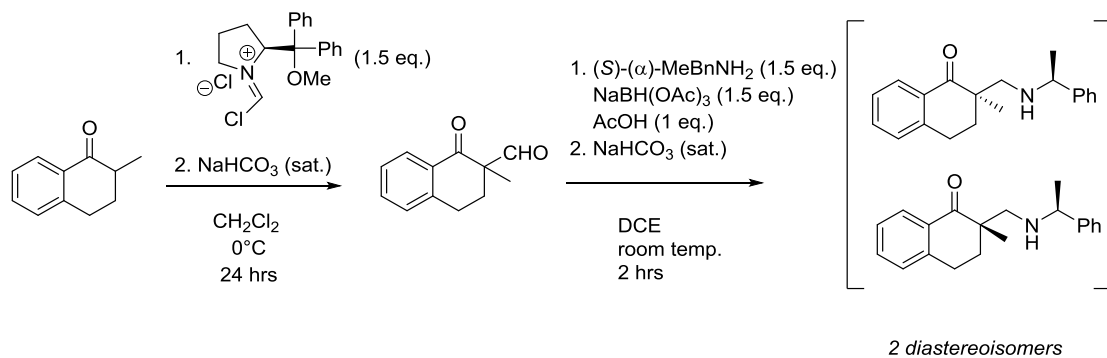

APPENDIX 5 ^1H NMR spectrum of crude product corresponding to data in entry 8 of Table 23 (page 138)

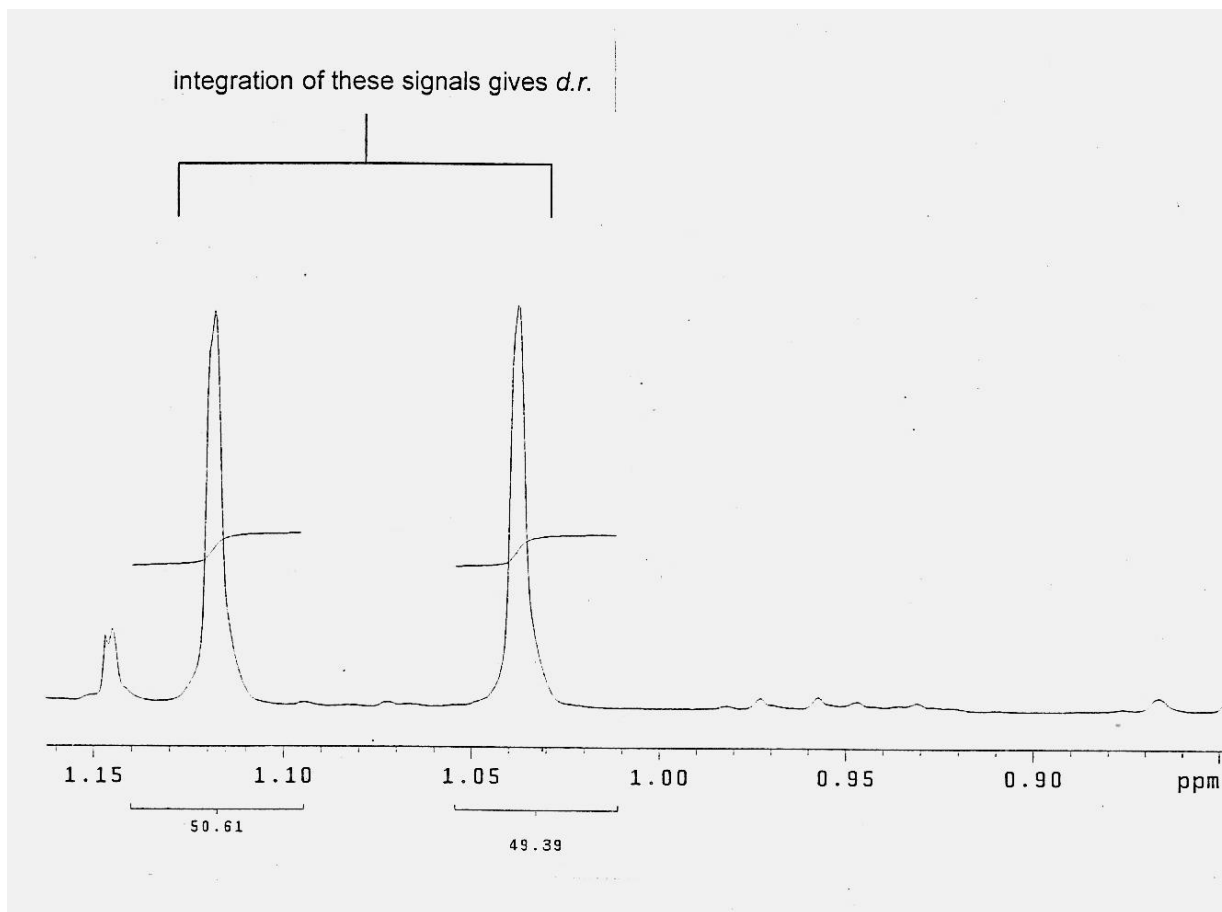
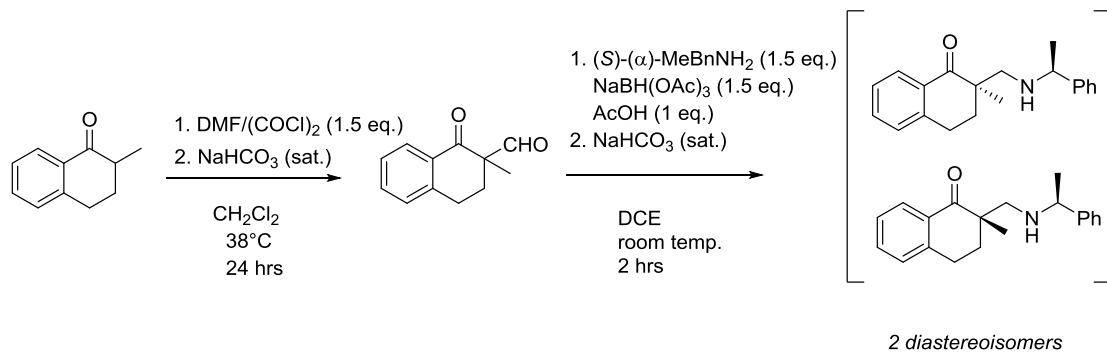

References

1. Arganat, I.; Caner, H.; Caldwell, J. *Nature Rev. Drug Discovery* **2002**, *1*, 753.
2. Triggle, D.J. *Drug Discovery Today* **1997**, *2*, 138.
3. Hornback, J. *Organic Chemistry*; Thomson Brooks/Cole: Belmont CA, **2006**, 244.
4. Chen, F.; Larsen, M.B.; Sánchez, C.; Wiborg, O. *European Neuropsychopharmacology* **2005**, *15*, 193.
5. Pandit, K. in *Introduction to the Pharmaceutical Sciences* Lippincott Williams and Wilkins: Baltimore **2007**, 87.
6. Stinson, S.C. *Chiral Chemistry* **2001**, *79*, 45.
7. Koul, S.; Parshad, R.; Taneja, S.; Qazi, G.N. *Tetrahedron* **2003**, *14*, 2459.
8. Harrington, P.J.; Lodewijk, E. *Organic Process Research and Development* **1997**, *1*, 72.
9. Clayden, J.; Greeves, N.; Warren, S.; Wothers, P. in *Organic Chemistry*, Oxford University Press: New York, **2001**, 402.
10. Clayden, J.; Greeves, N.; Warren, S.; Wothers, P. in *Organic Chemistry*, Oxford University Press: New York, **2001**, 1222.
11. Scott, J. W. in *Asymmetric Synthesis*, Vol 4; Morrison, J.D.; Scott, J. W. Eds.; Academic Press: London, **1984**, 74.
12. Stork, G.; Raucher, S. *J. Am. Chem. Soc.* **1976**, *98*, 1583.
13. Eidemshaus, C.; Reissig, H. *Eur. J. Org. Chem.* **2011**, 6056.
14. Gnás, Y.; Glorius, F. *Synthesis* **2006**, *12*, 1899.
15. Evans, D.A.; Helmchen, G.; Rüping, M. in *Asymmetric Synthesis – The essentials*; Christmann, E., Bräse, S., Eds.; John Wiley: Weinheim, **2008**, 3-9.
16. Kürti, L.; Czakó, B. in *Strategic Applications of Named Reactions in Organic Synthesis*, Elsevier Academic Press: Burlington, **2005**, 162.
17. Evans, D.A.; Bartroli, J.; Shih, T.L. *J. Am. Chem. Soc.* **1981**, *103*, 2127.
18. Abiko, A.; Liu, J.F.; Masamune, S. *J. Am. Chem. Soc.* **1997**, *119*, 2586.
19. Evans, D.A.; Starr, J.T. *J. Am. Chem. Soc.* **2003**, *125*, 13531.
20. Enders, D.; Eichenauer, H. *Angew. Chem. Int. Ed. Engl.* **1976**, *15*, 549.
21. Enders, D.; Bettray, W. in *Asymmetric Synthesis – The essentials*; Christmann, E., Bräse, S., Eds.; John Wiley: Weinheim, **2008**, 24.
22. Kürti, L.; Czakó, B. in *Strategic Applications of Named Reactions in Organic Synthesis*, Elsevier Academic Press Burlington MA, **2005**, 150.
23. Toro, A.; Nowak, P.; Deslongchamps, P. *J. Am. Chem. Soc.* **1998**, 2839.
24. Midland, M. M.; Tramontano, A. *J. Am. Chem. Soc.* **1997**, 134.
25. Kürti, L.; Czakó, B. in *Strategic Applications of Named Reactions in Organic Synthesis*, Elsevier Academic Press: Burlington MA, **2005**, 288.
26. Dussault, P. H.; Eary, C.T.; Woller, K.R. *J. Org. Chem.* **1999**, *64*, 1789.
27. Corey, E.J.; Bakshi, R.K.; Shibata, S. *J. Am. Chem. Soc.* **1987**, *109*, 7925.
28. Corey, E.J.; Bakshi, R.K.; Shibata, S.; Chen, C.; Singh, V.K. *J. Am. Chem. Soc.* **1987**, *109*, 5551.
29. Corey E. J.; Helal, C. *Angew. Chem. Int. Ed.* **1998**, *37*, 1986.
30. Kürti, L.; Czakó, B. in *Strategic Applications of Named Reactions in Organic Synthesis*, Elsevier Academic Press: Burlington MA, **2005**, 101.
31. Wallbaum, S.; Martens, J. *Tetrahedron: Asymmetry* **1992**, *3*, 1475.
32. Corey, E. J.; Roberts, B.E. *J. Am. Chem. Soc.* **1997**, *119*, 12425.
33. Katsuki, T.; Sharpless, K.B. *J. Am. Chem. Soc.* **1980**, *102*, 5974.
34. Hanson, R.M.; Sharpless, K.B. *J. Org. Chem.* **1986**, *51*, 1922.

35. Sharpless, K.B. (Nobel Lecture) *Angew. Chem. Int. Ed. Engl.* **2002**, *41*, 2024.
36. Pfenniger, A. *Synthesis* **1986**, 89.
37. Kürti, L.; Czakó, B. in *Strategic Applications of Named Reactions in Organic Synthesis*, Elsevier Academic Press: Burlington MA, **2005**, 408.
38. Paterson, I.; De Savi, C.; Tudge, M. *Org. Lett.* **2001**, *3*, 3149.
39. Noyori, R.; Ohta, M.; Hsiao, Y.; Kitamura, M.; Ohta, T.; Takaya, H. *J. Am. Chem. Soc.* **1986**, *108*, 7117.
40. Noyori, R. *Acta Chem. Scand.* **1996**, *50*, 380.
41. Noyori, R. (Nobel lecture) *Angew. Chem. Int. Ed.* **2002**, *41*, 2008.
42. Li, J.J.; Corey, E.J. in *Name Reactions for Functional Group Transformations*, John Wiley: New Jersey, **2007**, 50-52.
43. Genêt, J.P.; Ratovelomanana-Vidal, V.; Caño de Andrade, M.C.; Pfister, X.; Guerreiro, P.; Lenoir, J.Y. *Tetrahedron Lett.* **1995**, *36*, 4801.
44. MacMillan D. *Nature*, **2008**, *455*, 304.
45. D. Seebach *Angew. Chem. Int. Ed. Eng.* **1990**, *29*, 1320.
46. Dalko, P.I.; Moisan, L. *Angew. Chem. Int. Ed. Eng.* **2001**, *43*, 5138.
47. Austin, J. F.; MacMillan, D.W.C. *J. Am. Chem. Soc.* **2002**, *124*, 1172.
48. Mangion, I.K.; Northrup, A.B.; Macmillan, D.W.C. *Angew. Chem. Int. Ed.* **2004**, *43*, 6722.
49. Northrup, A.B.; MacMillan, D.W.C. *J. Am. Chem. Soc.* **2002**, *124*, 2458.
50. Sparr, C.; Schweizer, W.B.; Senn H.M.; Gilmour, R. *Angew. Chem. Int. Ed.* **2012**, *51*, 11890.
51. List, B. *Tetrahedron* **2002**, *58*, 5573.
52. Hajos, Z.G.; Parrish, D.R. *J. Org. Chem.* **1974**, *39*, 1615.
53. Notz, W.; List, B. *J. Am. Chem. Soc.* **2000**, *122*, 7386.
54. List, B.; Pojarliev, P.; Biller, W.T.; Martin, H.J. *J. Am. Chem. Soc.* **2002**, *124*, 827.
55. Palazzi, C.; Poli, G.; Scolastico, C.; Villa, R. *Tetrahedron Lett.* **1990**, *31*, 4223.
56. Capdevila, M.G.; Emer, E.; Gualandi, A.; Petruzzello D.; Grilli, S.; Cozzi P.G. *Chemcatchem* **2012**, *4*, 968.
57. Enders, D.; Vázquez, J. *Synlett* **1999**, 629.
58. Vilsmeier, A.; Haack, A. *Ber. Dtsch. Chem. Ges.* **1927**, *60*, 119.
59. Beyer, H.; Walter, W. in *Organic Chemistry*, Albion Publishing: Chichester, **1997**, 537.
60. Jutz, C. in *Adv. Org. Chem. Vol 9, Iminium Salts in Organic Chemistry*, pt. 1, Taylor, E.C. (Ed.), John Wiley, New York, **1976**, 225.
61. Jones, G.; Stanforth, S.P. in *Organic Reactions*, Vol. 49; (Ed.) Paquette L.A.; John Wiley: New York, **1997**, 3.
62. March, J.; Smith, M.B., in *March's Advanced Organic Chemistry*, John Wiley: Hoboken **2007**, 724.
63. Scott, M.D.; Spedding, H. *J. Chem. Soc.* **1968**, 1603.
64. Meth-Cohn, O.; Stanforth, S. P. in *Comprehensive Organic Synthesis*, Vol. 2; Trost, B. M.; Fleming, I., Eds.; Pergamon Press: Oxford, **1991**, 777.
65. Kikugawa, K.; Kawashima, T. *Chem. Pharm. Bull.* **1971**, *19*, 2629.
66. Bosshard, H.H.; Zollinger, H. *Helv. Chim. Acta* **1959**, *42*, 1659.
67. Cheung, G.K.; Downie, I.M.; Earle, H.; Heaney, H.; Matough, M.F.S.; Khamis, F.S.; Thomas, D. *Synlett* **1992**, 77.
68. Downie, I.M.; Earle, H.; Heaney, H.; Khamis, F.S. *Tetrahedron* **1993**, *49*, 4015.
69. Paul, S.; Gupta, M.; Gupta, R. *Synlett* **2000**, 1115.
70. Jacob, P.; Anderson, G.; Meshul, C.K.; Shulgin, A.T.; Castagnoli, N.Jr. *J. Med. Chem.* **1977**, *20*, 1235.

71. Cohn, O.M.; Cheng, Y. *Tetrahedron Lett.* **1996**, *37*, 2679.
72. Cohn, O.M.; Taylor, D.L. *J. Chem. Soc., Chem Commun* **1995**, 1463.
73. Bouka-Poba, J-P.; Farnier, M.; Guillard, R. *Tetrahedron Lett.* **1979**, *19*, 1717.
74. Chadwick, D.J.; Chambers, J.; Hargraves, H.E.; Meakins, G.D.; Snowden, R.L. *J. Chem.Soc., Perkin Trans.1*, **1973**, 2327.
75. Pedras, M.S.C.P.; Jha, M. *J. Org. Chem.* **2005**, *70*, 1828.
76. Walkup, R.E.; Linder, J. *Tetrahedron Lett.* **1985**, *26*, 2155.
77. Chatterjee, A; Biswas, K.M. *J. Org. Chem.* **1973**, *38*, 4002.
78. Jones, G.; Stanforth, S.P. in *Organic Reactions*, Vol. 56; (Ed.) Overman, L.E.; John Wiley **2000**, 356.
79. Reichardt, C. *J. Prakt. Chem.* **1999**, *7*, 341.
80. Katritzky, A.; Shcherbakota, I.V.; Tack, R.D.; Steel, P.J. *Can. J. Chem.* **1992**, *70*, 2040.
81. Reddy, C.P.; Tanimoto, S. *Synthesis* **1987**, 575.
82. Barton, D.H.R.; Dressaire, G.; Willis, B.J.; Barret, A.G.M.; Pfeffer, M. *J. Chem. Soc., Perkin Trans.1* **1982**, 665.
83. Gagan, J.M.F.; Lane, A.G.; Lloyd, D. *J. Chem. Soc.* **1970**, 2484.
84. Bruckner, R. in *Advanced Organic Chemistry* Harcourt/Academic Press: San Diego **2002**, 199.
85. Seus, E.J. *J. Org. Chem.* **1965**, *30*, 2818.
86. Grimwade, M.J.; Lester, M.G. *Tetrahedron* **1969**, *25*, 4535.
87. Traas, P.C.; Takken, H.J.; Boelens, H. *Tetrahedron Lett.* **1977**, *24*, 2129.
88. Liljefors, S.; Hallberg, A. *Tetrahedron Lett.* **1978**, *46*, 4573.
89. Ziegenbein, W. *Angew. Chem. Int. Ed. Engl.* **1965**, *4*, 358.
90. Jameleddine, K.; Bechir, B.H.; Mustapha, M. *Synthetic Comm.* **2000**, *30*, 2762.
91. Marson, C.M. *Tetrahedron* **1992**, *48*, 3659.
92. Giles P.R.; Marson C.M. *Tetrahedron Lett.* **1990**, *31*, 5227.
93. Chakraborty, A.; Ray, J.K. *Synthetic Comm.* **1995**, *12*, 1869.
94. V. Fringuelli, F.; Serena, B.; Taticchi, A. *J. Am. Chem. Soc., Perkin Trans. 2* **1980**, 971.
95. Traas, P.C.; Takken, H.J.; Boelens, H. *Tetrahedron Lett.* **1977**, *18*, 2027.
96. Fringuelli, F.; Serena, B.; Taticchi, A. *J. Chem. Soc., Perkin Trans. 2* **1980**, 971.
97. Smith, K.M.; Pandey, R.K. *J. Chem. Soc., Perkin Trans. 1* **1987**, 1229.
98. Karlsson, J.O.; Frejd, T. *J. Org. Chem.* **1983**, *48*, 1921.
99. Sciaky, R.; Mancini, F. *Tetrahedron Lett.* **1965**, 137.
100. House, O.H.; Czuba, J.L.; Gall, M.G.; Olmstead, H.D. *J. Org. Chem.* **1969**, *34*, 2324.
101. Nyangulu, J.M.; Nelson, K.M.; Rose, P.A.; Gai, Y.; Loewen, M.; Loughheed, B.; Quail, J.W.; Cutler, A.J.; Abrams, S.R. *Org. Biomol. Chem.* **2006**, *4*, 1400.
102. Mitani, M.; Nakayama, M.; Koyama, K. *Tetrahedron Lett.* **1980**, *21*, 4457.
103. Martinez, A.; Marcos, F.; Estevez, J.C.; Ramon, E.; Castedo, L. *Tetrahedron* **2005**, *61*, 485.
104. Imai, M.; Hagihara, A.; Kawasaki, H.; Kei, M.; Koga, K. *Tetrahedron* **2000**, *56*, 179.
105. Roca, F.X.; Richards, C.J. *Chem. Commun.* **2003**, *24*, 3002.
106. Zhang, S.; Wang, Z.; Xu, M.; Lin, G., *Org. Lett.* **2010**, *12*, 5546.
107. Rodney, K.F.; Jadhav, A.V.; Singh, P.N.D.; Chang, M.; Vanos, C.; Sankaranarayanan, J.; Vu, M.; Ibrahim, N.; Ross, E.; McCloskey, S. *J. Org. Chem.* **2007**, *72*, 6372.
108. Shibuya, M.; Tomizawa, M.; Sasano, Y.; Iwabachi, Y. *J. Org. Chem.* **2009**, *74*, 4619.
109. Berman, J.D.; Stanley, J.H.; Sherman, W.V.; Cohen, S.G. *J. Am. Chem. Soc.* **1963**, *85*, 4010.
110. Abdel-Magid, A.; Carson, K.; Harris, B.D.; Maryanoff, C.; Shah, R.D. *J. Org. Chem.* **1996**, *61*, 3849.

111. Hirokazu, A.; Uemara, D. in *Quaternary Stereocenters*; Christoffers, J.; Baro, A., Eds; John Wiley: Weinheim, **2005**, 2-3.
112. Hirose, T.; Sunazuka, T.; Yamamoto, D.; Harigawa, Y.; Kuwajima, I.; Omura, S. *Org. Lett.* **2002**, *4*, 501.
113. Degnan, A.P.; Meyers, A.I. *J. Am. Chem. Soc.* **1999**, *121*, 2762.
114. Denissova, I.; Barriault, L. *Tetrahedron* **2003**, *59*, 10105.
115. Huang, Y.; Iwama, T.; Rawal, V. H. *J. Am. Chem. Soc.* **2002**, *124*, 5950.
116. Baro, A.; Christoffers, J. in *Quaternary Stereocenters*; Christoffers, J.; Baro, A., Eds; John Wiley: Weinheim, **2005**, 108.
117. Christoffers, J.; Mann, A. *Angew. Chem. Int. Ed.* **2000**, *39*, 2871.
118. Hinderaker, M.P.; Raines, R.T. *Protein Science* **2003**, *12*, 1188.
119. Sibi, M.P.; Manyem, S. *Org. Lett.* **2002**, *4*, 2929.
120. Delaunay, D.; Le Corre, M. *J. Am. Chem. Soc. Perkin Trans. I.* **1994**, 3041.
121. Clayden, J.; Greeves, N.; Warren, S.; Wothers, P. in *Organic Chemistry*, Oxford University Press: New York, **2001**, 1139.
122. Sparr, C.; Tanzer, E.; Bachmann, J.; Gilmour, R. *Synthesis* **2010**, 1394.
123. Enders, D.; Kipphardt, H.; Gerdes, P.; Brena-Valle, L.J.; Bhushan, V. *Bull. Soc. Chim. Belg.* **1988**, *97*, 691.
124. Ram, S.; Spicer, L.D. *Synthetic Comm.* **1987**, *17*, 415.
125. Sparr, C.; Zimmer, L.E.; Gimour, R. in *Asymmetric Synthesis – The essentials*, Christmann, E.; Bräse, S. (Eds.); John Wiley: Weinheim, **2012**, 117.
126. Rapp, M.; Bilska, M.; Koroniak H. *J. Fluorine Chem.* **2011**, *132*, 1232.
127. Kempf, B.; Hampel, N.; Offial, A.; Mayr, H. *Chem. Eur. J.* **2003**, *9*, 2209.
128. Duhamel L.; Plaquevent J.C. *Bulletin de la Societe Chemie* Vol. 3-4 **1982**, 69.
129. Kagan, H.B.; Fiaud, J.C. in *Topics in Stereochemistry*, Vol. 18; Eliel, E.L, Wilen, S.H. (Eds); John Wiley: New York, **1988**, 250.
130. Shiina I.; Kawakita, Y. *Tet.* **2004**, *60*, 4729.
131. Ohta, T.; Takaya H.; Kitamura M.; Nagai, K.; Noyori R. *J. Org. Chem.* **1987**, *52*, 3174.
132. Prakash, S.G.K.; Paknia, F.; Vaghoo, H.; Rasul, G.; Mathew, T.; Olah., G.A. *J. Org. Chem.* **2010**, *75*, 2219.
133. Vita, M.V.; Waser, J. *Org. Lett.* **2013**, *15*, 3246.
134. Caseau, P.; Duboudin, F.; Moulines, F.; Babot, O.; Dunogues, J. *Tetrahedron* **1987**, *43*, 2075.