

Versican splice variant messenger RNA expression in normal human Achilles tendon and tendinopathies

A. N. Corps, A. H. N. Robinson¹, T. Movin², M. L. Costa¹, D. C. Ireland³,
B. L. Hazleman and G. P. Riley

Objectives. Versican is the principal large proteoglycan expressed in mid-tendon, but its role in tendon pathology is unknown. Our objective was to define the expression of versican isoform splice variant messenger ribonucleic acid (mRNA) in normal Achilles tendons, in chronic painful tendinopathy and in ruptured tendons.

Methods. Total RNA isolated from frozen tendon samples (normal $n = 14$; chronic painful tendinopathy $n = 10$; ruptured $n = 8$) was assayed by relative quantitative reverse transcriptase polymerase chain reaction (RT-PCR) for total versican, versican variants V0, V1, V2, V3 and type I collagen $\alpha 1$ mRNA, normalized to glyceraldehyde-3-phosphate dehydrogenase (GAPDH). Differences between sample groups were tested by Wilcoxon statistics.

Results. Painful and ruptured tendons showed a significant decrease (median 2-fold) in the expression of versican mRNA, in contrast to an increased expression (median 8-fold) of type I collagen $\alpha 1$ mRNA in painful tendons. Versican splice variants V0 and V1 mRNA were readily detected in normal samples, V3 levels were substantially lower, and V2 levels were more variable. Each of V1, V2 and V3 mRNA showed significant decreases in expression in painful and ruptured tendons, but V0 was not significantly changed.

Conclusions. Changes in versican expression relative to that of collagen, and alterations in the balance of versican splice variants, may contribute to changes in matrix structure and function in tendinopathies.

KEY WORDS: Tendon, Tendinopathy, Versican, Proteoglycan.

The large extracellular matrix proteoglycan versican contributes to the structural properties of the matrix through its ability to bind hyaluronic acid and the glycosaminoglycan (GAG) chondroitin sulphate, and also modulates cell growth, migration and differentiation [1]. There are four versican isoforms, which contain different combinations of two GAG-binding domains, termed $GAG\alpha$ and $GAG\beta$, due to differential splicing of exons 7 and 8: V0 has both of these domains, V1 has $GAG\beta$ only, V2 has $GAG\alpha$ only and V3 has neither [2, 3]. The wide range of interactions mediated by versican is thought to result from differential expression of the GAG domains and from properties conferred by the N- and C-terminal domains [1].

In tendons, studies of both protein and messenger ribonucleic acid (mRNA) localization have indicated that there is site-specific distribution of the large proteoglycans: versican is predominant in the tensile region of the mid-tendon, while aggrecan is more highly expressed in the fibrocartilagenous regions at the insertion sites or where the tendon wraps around bone [4, 5]. Versican forms an integral part of a pericellular matrix that organizes the tendon cells in linear arrays between collagen fascicles [6]. The splice variants of versican that are expressed in human tendons such as the Achilles have not been described. These tendons are commonly subject to chronic painful degeneration or 'tendinosis' [7, 8], and to rupture, which is often spontaneous, i.e. previously asymptomatic, although underlying histochemical changes are frequently present [9, 10]. Most tendon damage occurs in the mid-tendon region, with structural and biochemical changes including increased levels of

GAG [7–10]. Whether versican is involved in these tendinopathies is not known. We have developed relative quantitative reverse transcriptase polymerase chain reaction (RT-PCR) assays for total versican and the different splice variants, and we have addressed two questions: which versican splice variant mRNAs are expressed in Achilles tendon and how does versican mRNA expression change in tendinopathies?

Materials and methods

Materials

Oligonucleotide primers for RT-PCR were obtained from Invitrogen (Paisley, UK). One-Step RT-PCR reagents and fluorescein (FAM)-labelled oligonucleotide probes were obtained from Applied Biosystems (Warrington, UK).

RNA isolation from tendon specimens

All procedures were approved by the Cambridge Local Research Ethics Committee and written consent was obtained from informed patients. Tendon specimens were obtained from tissue discarded during surgery, from 10 patients suffering painful tendinopathy for more than 6 months, and from eight patients undergoing repair of ruptured tendon within 48 h of the rupture occurring. Macroscopically normal specimens were obtained from

Rheumatology Research Unit and ¹Department of Trauma and Orthopedics, Addenbrooke's Hospital, Cambridge, UK, ²Karolinska Institute, Centre for Surgical Studies, Department of Orthopedic Surgery, Karolinska University Hospital/Huddinge, Stockholm, Sweden and ³Bone Research Group, Department of Medicine, University of Cambridge, Cambridge, UK.

Submitted 30 January 2004; revised version accepted 8 April 2004.

Correspondence to: A.N. Corps, Rheumatology Research Unit, Box 194, Addenbrooke's Hospital, Cambridge CB2 2QQ, UK.
E-mail: anc@mole.bio.cam.ac.uk

cadaver material (14 individuals) within 48 h of death. The age of the individuals from which tissue was taken was as follows: normal tendon, 20–97 yr (mean = 58 yr; median = 54 yr); painful tendinopathy, 32–58 yr (mean = 44 yr; median = 44 yr); ruptured tendon, 33–69 yr (mean = 47 yr; median = 44 yr). Pieces of mid-tendon (between 10 and 70 mg wet weight) were frozen at -70°C .

RNA was isolated from the frozen tissue samples by a modified Tri-Spin protocol as described previously [11], resuspended in 100 μl water, and quantitated using the RiboGreen assay (Molecular Probes, Leiden, The Netherlands). The majority of samples yielded between 20 and 70 ng RNA/mg wet weight, consistent with our previous experience of human tendon samples of low cellularity [11]. The RNA was diluted to 1 ng/ μl , and stored at -70°C as aliquots which were thawed once only.

Relative quantitative RT-PCR

One-Step RT-PCR reactions were performed in a GeneAmp 5700 (Applied Biosystems, Warrington, UK). Primers and probes for glyceraldehyde-3-phosphate dehydrogenase (GAPDH) and type I collagen $\alpha 1$ -chain (collI $\alpha 1$) have been described previously [11]. Primers and probes for versican mRNA were designed using Primer Express (Applied Biosystems). BLASTn searches (www.ncbi.nlm.nih.gov/BLAST) revealed no significant similarity to other sequences. The forward primer (F), reverse primer (R) and probe (P) sequences were as follows:

Total versican (accession number U16306: bp 161–277):
 F = CCACCACGCTTCCTATGTGA
 R = TTTATGAACATCTTGGCCTTGGA
 P = CGCCGAACCCAGTCGCGC
 Versican V0 (accession number U16306: bp 4210–4314):
 F = GCACAAAATTTACCCCTGACAT
 R = CTGAATCTATTGGATGACCAATTACAC
 P = ATCACTCATTCGACCTGTCTTATTTCTCTGACC
 Versican V1 (accession number X15998: bp 1231–1353):
 F = TGAGAACCCTGTATCGTTTTGAGA
 R = as V0
 P = AATCACTCATTTCGACGTTTAAAGCAGTAGGCA
 Versican V2 (accession number U26555: bp 4210–4305):
 F = as V0
 R = CGTTAAGGCACGGGTTTCATT
 P = TCAGAGAAAATAAGACAGGACCTGATCGCTGC
 Versican V3 (accession number D32039: bp 1070–1183):
 F = as V1
 R = as V2
 P = CAGATTTGATGCCTACTGCTTTAAACGACCTG

All probes were chosen to span exon splice junctions. The amplicon for total versican mRNA spans the splice junction between exons 3 and 4, which are present in all variants [3]. The variant-specific amplicons span the variably deleted exons 7 and 8 (Fig. 1), the sizes of which (2961 bp and 5262 bp) prevent amplification of the wrong products from shared primer sequences, and each primer pair generated a single product of the appropriate size. No signal was produced if either the RNA or the reverse transcriptase was omitted. To confirm that each of the assays was not affected by the presence of the shared sequences within the other variants, we prepared and used longer PCR products from the V0 and V1 variants. Each of these acted as a template in the assay of the respective variant, but did not interfere or generate signals in assays of each of the other variants (data not shown).

Standard curves were run in each assay, using freshly-diluted aliquots of pooled tendon tissue or cell RNA, or of brain RNA for versican V2. For each target, this produced a linear plot of threshold cycle (Ct) against log(dilution), whose slope was within 10% of the expected value, indicating a similar, near-maximum efficiency for each target. All tissue RNA samples were assayed in duplicate on the same plate at 2 ng/well, and each target assay was

performed at least twice with similar results. The values obtained for versican mRNA expression were normalized for GAPDH mRNA expression in the same sample, using the formula

$$\text{versican/GAPDH} = 2^{[\text{Ct}(\text{GAPDH}) - \text{Ct}(\text{versican})]}$$

The expression of GAPDH mRNA showed some heterogeneity between tissue samples, particularly in the group from ruptured tendons. However, there was no overall significant difference in GAPDH expression between the three tissue sample groups.

Analysis of data

Comparison of the expression levels of each versican mRNA between tissue sample groups was performed using the Wilcoxon rank sum test.

Results

Using an assay which detects all reported splice variants of versican, we found that the total versican mRNA expression in tendon samples was generally in the range 0.1–1 compared with that of GAPDH, i.e. moderately high levels. Compared with the expression in normal tendons, both painful and ruptured tendons showed a significant decrease (median 2-fold) in the expression of versican mRNA (Fig. 2A). In contrast, the expression of collI $\alpha 1$ mRNA showed a marked (median 8-fold) increase in samples of painful tendon but was more variable in samples of ruptured tendon (Fig. 2B).

Using assays specific for versican splice variant mRNA, we found that all four variants were expressed in most samples (Fig. 2). The similar optimized efficiencies of the different assays allowed approximate comparisons between the different variants. In normal tendon samples, V0 and V1 mRNA were consistently expressed at similar levels (estimates of the median V0/V1 ratio were 1.0, 1.4 and 1.8 in three separate pairs of assays), and were generally about 10-fold higher than V3 mRNA. Variant V2 mRNA showed the most variable expression, ranging from similar to that of V0 and V1 mRNA in some samples to less than that of V3 mRNA in other samples. In painful and ruptured tendon samples, V1 mRNA showed reduced expression compared with normal samples (median 2-fold), i.e. similar to that observed in total versican mRNA (Figs 2A, D). V2 and V3 mRNA showed proportionally greater reductions, the levels being near or below the detection limit in some samples (Figs 2E, F). In contrast, the expression of V0 mRNA in painful or ruptured tendon samples was not significantly different from that in normal tendon samples (Fig. 2C). In painful tendon samples the ratio of V0/V1 or V0/(total versican) was doubled compared with normals ($P < 0.05$), but in ruptured tendon samples these ratios showed greater variation and no significant difference.

Discussion

Versican expression has been detected in many adult human tissues [12, 13]. The expression of the different splice variant mRNA varies considerably, indicating complex levels of regulation, and only three out of 21 tissues screened expressed all four variants at levels considered significant [13]. Variant V2 predominated in brain [14], but was not detected in vascular smooth muscle cells [15]. Variant V1 was the predominant form expressed in many tissues [13], including cartilage, in which V0 and V3 were additionally expressed only in the fetus [16]. We have shown here that versican mRNA is expressed in normal and degenerate mid-tendon. Although V0 and V1 mRNA were generally expressed at readily detectable levels, both total versican mRNA and the individual

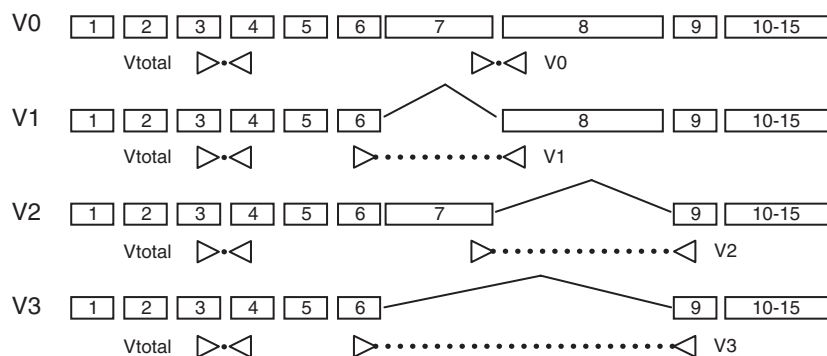

FIG. 1. Versican exon structure showing location of primers for total and variant-specific RT-PCR.

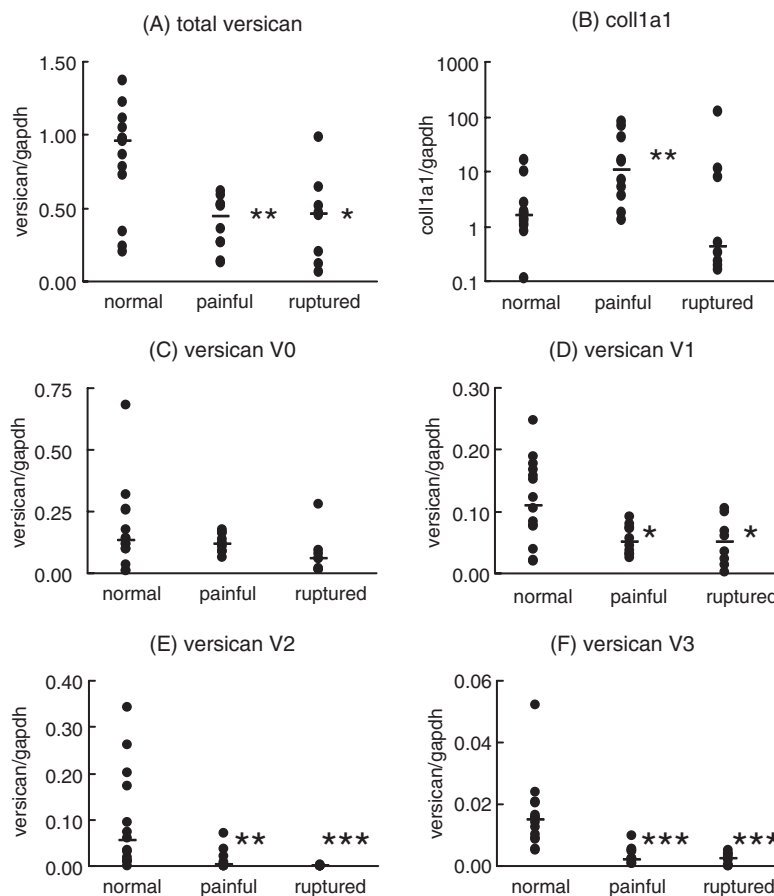

FIG. 2. Expression of versican and *coll1a1* mRNA in normal, painful and ruptured tendons: (A) total versican mRNA, (B) *coll1a1* mRNA and (C–F) versican splice variant V0, V1, V2 and V3 mRNA were assayed and normalized for GAPDH mRNA. Each point represents a separate sample, and the median values are indicated. * $P < 0.05$, ** $P < 0.01$, *** $P < 0.001$ compared with the normal sample group.

splice variants showed rather large variation within the sample groups, particularly the normal group, in which the proportion of V2 mRNA was most variable. We do not know the basis for this variation. However, since tendon is generally of low cellularity, some of the variation may result from the inclusion of different cell types, perhaps reflecting vascularization or innervation. Alternatively, some of the normal samples may be affected by subclinical degeneration: histopathological changes were reported in 34% of normal (i.e. asymptomatic) tendons [9]. In cell culture

studies, we have found that fibroblasts derived from tendon explants express variant V0 and V1 mRNA at substantially higher levels than variant V3, while V2 expression is low or undetectable (ANC, unpublished data). We will use this model to investigate the regulation of versican expression in tendon.

In samples from painful and ruptured tendons there was decreased expression of versican mRNA. In earlier work, we reported an increase in versican mRNA in three out of four degenerate Achilles tendon samples (two painful and two

ruptured) compared with the normal control, analysed on a complementary deoxyribonucleic acid (cDNA) array [11]. The contrast between the two studies may have arisen from the small number of samples screened in the earlier work, with the normal control being equivalent (in versican mRNA content) to the lower end of the range described here. In the present study, the decrease in versican mRNA in painful tendon samples was observed for each variant except V0, so that the proportion of V0 relative to the other variants doubled. An opposite result was obtained in abdominal aortic aneurysm, where the expression of V0 mRNA decreased but that of V1 remained constant [17], again indicating situation-specific regulation of the splice variants. The decrease in versican mRNA contrasted with a substantially increased expression of coll α 1 mRNA in the painful tendon samples. Versican and collagen expression also show reciprocal regulation in the cervix during pregnancy and involution, presumably reflecting a physiological change in matrix structure and function [18]. The contribution of decreased versican mRNA expression and an altered balance of versican splice variants to the structural and functional changes in tendinopathies remains to be established. It will be important to determine whether the changes in versican mRNA expression are translated into changes at the protein level.

Among the biochemical changes occurring in tendinopathies are increased levels of GAG [7–10], but it is not known which proteoglycans are involved. A similar increase in GAG (median 3.5-fold) occurred in the samples of painful tendon used in this study (VA Curry and GPR, unpublished data), despite the significantly decreased level of versican mRNA. The increase in GAG in tendinopathies may therefore result from increased expression of other proteoglycans (such as decorin, biglycan, fibromodulin or syndecans), although increased saturation of GAG-binding sites in versican and decreased turnover of proteoglycan cannot be excluded. We are currently adapting methods of proteoglycan identification and analysis to the small samples of human tendon available, in order to address this question.

<i>Rheumatology</i>	Key messages
	<ul style="list-style-type: none"> • In mid-tendon, the principal versican mRNA splice variants encode V0 and V1. • Decreased versican mRNA expression may contribute to altered matrix structure and function in chronic tendinopathy and ruptured tendon.

Acknowledgements

We thank the teams in the operating theatres and mortuary at Addenbrooke's Hospital for their cooperation in sample collection, and Mr G. Holloway (Reading), Mr R. Hackney (Leeds) and Mr M. Allen (Leicester) for the provision of additional samples. This work was supported by the Arthritis Research Campaign (project grants R0561, R0574 and R0603), the Cambridge Arthritis Research Endeavour, the Isaac Newton Trust and the Sybil Eastwood Memorial Trust.

The authors have declared no conflicts of interest.

References

1. Wight TN. Versican: a versatile extracellular matrix proteoglycan in cell biology. *Curr Opin Cell Biol* 2002;14:617–23.
2. Dours-Zimmermann MT, Zimmermann DR. A novel glycosaminoglycan attachment domain identified in two alternative splice variants of human versican. *J Biol Chem* 1994;269:32992–8.
3. Naso MF, Zimmermann DR, Iozzo RV. Characterization of the complete genomic structure of the human versican gene and functional analysis of its promoter. *J Biol Chem* 1994;269:32999–3008.
4. Robbins JR, Vogel KG. Regional expression of mRNA for proteoglycans and collagen in tendon. *Eur J Cell Biol* 1994;64:264–70.
5. Waggett AD, Ralphs JR, Kwan APL, Woodnutt D, Benjamin M. Characterization of collagens and proteoglycans at the insertion of the human Achilles tendon. *Matrix Biol* 1998;16:457–70.
6. Ritty TM, Roth R, Heuser JE. Tendon cell array isolation reveals a previously unknown fibrillin-2-containing macromolecular assembly. *Structure* 2003;11:1179–88.
7. Aström M, Rausing A. Chronic Achilles tendinopathy. A survey of surgical and histopathologic findings. *Clin Orthop* 1995;316:151–64.
8. Jarvinen M, Jozsa L, Kannus P, Jarvinen TLN, Kvist M, Leadbetter W. Histopathological findings in chronic tendon disorders. *Scand J Med Sci Sports* 1997;7:86–95.
9. Kannus P, Jozsa L. Histopathological changes preceding spontaneous rupture of a tendon. *J Bone Joint Surg* 1991;73A:1507–25.
10. Maffulli N, Barras V, Ewen SWB. Light microscopic histology of Achilles tendon ruptures: a comparison with unruptured tendons. *Am J Sports Med* 2000;28:857–63.
11. Ireland D, Harrall RL, Holloway G, Hackney R, Hazleman BL, Riley GP. Multiple changes in gene expression in chronic human Achilles tendinopathy. *Matrix Biol* 2001;20:159–69.
12. Bode-Lesniewska B, Dours-Zimmermann MT, Odermatt BF, Breiner J, Heitz PU, Zimmermann DR. Distribution of the large aggregating proteoglycan versican in adult human tissues. *J Histochem Cytochem* 1996;44:303–12.
13. Cattaruzza S, Schiappacassi M, Ljugberg-Rose A *et al.* Distribution of PG-M/versican variants in human tissues and *de novo* expression of isoform V3 upon endothelial cell activation, migration and neoangiogenesis *in vitro*. *J Biol Chem* 2002;277:47626–35.
14. Paulus W, Baur I, Dors-Zimmermann MT, Zimmermann DR. Differential expression of versican isoforms in brain tumours. *J Neuropathol Exp Neurol* 1996;55:528–33.
15. Lemire JM, Braun KR, Maurel P, Kaplan ED, Schwartz SM, Wight TN. Versican/Pg-M isoforms in vascular smooth muscle cells. *Arterioscler Thromb Vasc Biol* 1999;19:1630–9.
16. Sztrolovics R, Grover J, Cs-Szabo G *et al.* The characterization of versican and its message in human articular cartilage and intervertebral disc. *J Orthop Res* 2002;20:257–66.
17. Theocharis AD, Tsolakis I, Hjerpe A, Karamanos NK. Human abdominal aortic aneurysm is characterized by decreased versican concentration and specific downregulation of versican isoform V0. *Atherosclerosis* 2001;154:367–76.
18. Westergren-Thorsson G, Norman M, Björnsson S *et al.* Differential expressions of mRNA for proteoglycans, collagens and transforming growth factor-beta in the human cervix during pregnancy and involution. *Biochim Biophys Acta* 1998;1406:203–13.